

Housing Design for Cattle

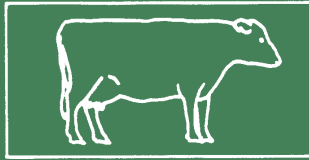
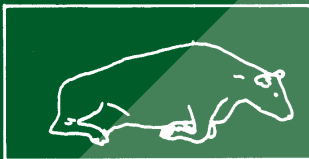
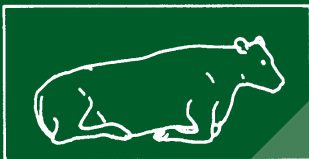

Interdisciplinary
report • Third edition 2001

**Danish
Recommendations**

**The Danish Agricultural Advisory Center
November 2002**

Translation

Gitte Grand Graversen The Information Department, The Danish Agricultural Advisory Center

Proof-reading

Mette Bjerring The Danish Cattle Federation, The Danish Agricultural Advisory Center
Inger Dalgaard The National Department of Farm Buildings and Machinery,
The Danish Agricultural Advisory Center
Ole Kristensen The Danish Cattle Federation, The Danish Agricultural Advisory Center
Christian C. Krohn Danish Institute of Agricultural Sciences, Research Center Foulum
Jan Brøgger Rasmussen The National Department of Farm Buildings and Machinery ,
The Danish Agricultural Advisory Center
Øyvind Runge The Danish Cattle Federation, The Danish Agricultural Advisory Center

Layout

Inger Camilla Fabricius The Danish Cattle Federation, The Danish Agricultural Advisory Center

Illustration

Niels Peter Nicolajsen The National Department of Farm Buildings and Machinery,
The Danish Agricultural Advisory Center

Printed by

Specialtrykkeriet i Viborg

Numbers printed

1.000

Housing Design for Cattle – Danish Recommendations



Interdisciplinary report

Third edition

2001



Translated into English

and issued in 2002

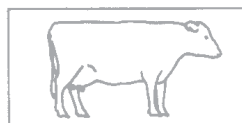

Preface

Now the third revised edition of the interdisciplinary report "Housing Design for Cattle – Danish Recommendations" is ready. As the previous editions it is to be considered as a status in a continuous process of finding the most optimal housing designs to the benefit of animals as well as human beings.

The report is based on animal requirements for near environment, behaviour, health and production.

The first edition was published in January 1991. Second edition was published in October 1995. Since 1995, several new research results and much knowledge have been produced concerning for instance dairy cow and young stock housing, entirely or partly open housing systems, ventilation and climate as well as design and function of the milking area.

Additionally a series of editorial changes has been carried out in the structure of the individual sections of this edition.

The report is the result of a cooperation between a number of research and experimental institutions as well as the agricultural advisory service.

The report can be cited with indication of sources.

The Danish Agricultural Advisory Center
December 2000

This English edition is a complete and accurate translation of the third edition of the report and no editing or alterations have been made except from a few necessary changes to the layout of the publication.

*The Danish Agricultural Advisory Center
November 2002*

The following persons have contributed to the report:

Senior Adviser Ole Kristensen

The National Department of Danish Cattle Husbandry, The Danish Agricultural Advisory Center

Senior Adviser Jan Brøgger Rasmussen

The National Department of Farm Buildings and Machinery, The Danish Agricultural Advisory Center

Adviser Inger Dalgaard

The National Department of Farm Buildings and Machinery, The Danish Agricultural Advisory Center

Head of Section Jens Yde Blom

The National Department of Danish Cattle Husbandry, The Danish Agricultural Advisory Center

Certificate in dairy herd health Mogens Jakobsen

Danish Veterinary Association

Farm Building Adviser Ole Ugelvig

Aabenraa Local Department of Farm Buildings and Machinery, Association for Agricultural Construction Advisers

Farm Building Adviser Helge Kromann

Viborg Local Department of Farm Buildings and Machinery, Association for Agricultural Construction Advisers

Cattle and Farm Building Adviser Robert Pedersen

Morsø Agricultural Advisory Centre, Danish Cattle Advisers' Association

Head of Department Per Justesen

Danish Dairy Board

Senior Consultant Laust Jepsen

Danish Dairy Board

Head of research unit Christian C. Krohn

Danish Institute of Agricultural Sciences, Research Center Foulum

Scientist Kaj Hansen

Danish Institute of Agricultural Sciences, Research Center Bygholm

Associate Professor Niels Rørbech

Department of Animal Science and Animal Health, The Royal Veterinary and Agricultural University

When referring to the report the following literature reference must be stated:

Anonymous, 2001. Interdisciplinary report "Housing Design for Cattle – Danish Recommendations. Third edition 2001". The Danish Agricultural Advisory Center. Translated into English and issued in 2002. 122 pp.

Contents

| | |
|--|-----------|
| Preface | 4 |
| Contents | 6 |
| Introduction | 10 |
| 1. Cattle behaviour | 12 |
| 1.1 Cattle senses | 12 |
| 1.2 Social behaviour | 13 |
| 1.2.1 Communication | 13 |
| 1.2.2 Individual distance requirements | 13 |
| 1.2.3 Ranking and rank criteria | 14 |
| 1.2.4 Aggressive behaviour | 15 |
| 1.2.5 Social grooming | 15 |
| 1.3 Circadian rhythm and activity patterns | 16 |
| 1.3.1 Lying time, lying frequency and circadian rhythm | 16 |
| 1.3.2 Lying down and getting up behaviour | 16 |
| 1.3.3 Lying down positions | 17 |
| 1.3.4 Choice of lying place and bedding | 18 |
| 1.3.5 Movement | 19 |
| 1.4 Comfort behaviour | 19 |
| 1.5. Feed and water intake | 20 |
| 1.5.1 Grazing and circadian rhythm | 20 |
| 1.5.2. Feed intake in housing systems | 21 |
| 1.5.3 Restrictive feeding | 21 |
| 1.5.4 Ad lib feeding | 21 |
| 1.5.5 Rumination | 21 |
| 1.5.6 Water intake | 21 |
| 1.6 Reproduction | 22 |
| 1.6.1 Sexual behaviour of bulls | 22 |
| 1.6.2 Sexual behaviour of cows | 22 |
| 1.6.3 Calving and the cow's behaviour towards the calf | 22 |
| 1.6.4 Behaviour of calves | 23 |
| 1.6.5 Sucking and eating behaviour of calves | 24 |
| 1.6.6 Separation and weaning | 25 |
| 1.7 Undesirable behaviour | 25 |
| 1.8 Literature | 27 |
| 1.8.1 Sources | 27 |
| 2. Weight, body dimensions and movement behaviour | 28 |
| 2.1 Cattle weight and dimensions | 28 |
| 2.2 Young stock weight and dimensions | 28 |
| 2.3 Body dimensions of cows | 28 |
| 2.4 Cattle movement pattern | 28 |
| 2.5 Freedom of movement and exercise | 30 |
| 2.6 Literature | 31 |
| 2.6.1 Sources | 31 |
| 2.6.2 Supplementary literature | 31 |
| 3. Health | 32 |
| 3.1 General health state | 32 |
| 3.2 External infection protection | 33 |
| 3.2.1 Purchase of cattle | 33 |
| 3.2.2 Handing over cattle | 33 |
| 3.2.3 Admittance of persons | 34 |
| 3.3 Internal infection protection | 35 |
| 3.3.1 Moving around cattle within farm | 35 |
| 3.3.2 Placing and moving around cattle and young stock | 35 |
| 3.3.3 Sick cattle and cattle under treatment | 35 |
| 3.4 Separation and treatment section | 35 |
| 3.4.1 Space for hoof trimming | 36 |

| | |
|---|-----------|
| 3.4.2 Medicine and chemical storage | 36 |
| 3.4.3 Waste handling | 36 |
| 3.5 Cleaning and disinfection | 36 |
| 3.5.1 General cleaning information | 36 |
| 3.5.2 Specific information about disinfection, including instructions | 36 |
| 3.6 Literature | 37 |
| 4. Work routines and supervision | 38 |
| 4.1 Work routines, supervision and welfare | 38 |
| 4.2 Cleaning and grooming | 38 |
| 4.3 Hoof care | 38 |
| 4.4 Supervision of housing climate | 39 |
| 4.5 Herd supervision | 39 |
| 4.6 Herd handling | 39 |
| 4.7 Handling of cattle and animal – human relations | 40 |
| 4.7.1 Calves, heifers and cows | 41 |
| 4.7.2 Bulls | 42 |
| 4.8 Taking into use renovated and new housing systems | 42 |
| 4.8.1 When will the new housing be taken into use? | 42 |
| 4.8.2 Making ready housing and technique | 42 |
| 4.9 Literature | 44 |
| 4.9.1 Sources | 44 |
| 4.9.2 Supplementary literature | 44 |
| 5. Housing Climate | 46 |
| 5.1 Introduction – housing climate in general | 46 |
| 5.2 Climatic requirements | 46 |
| 5.2.1 Temperature | 46 |
| 5.2.2 Air humidity | 47 |
| 5.2.3 Wind speed | 47 |
| 5.2.4 Precipitation | 47 |
| 5.2.5 Gases | 47 |
| 5.2.6 Dust | 47 |
| 5.2.7 Light | 47 |
| 5.2.8 Sound | 48 |
| 5.3 Building insulation | 48 |
| 5.3.1 Insulated buildings | 48 |
| 5.3.2 Uninsulated buildings | 48 |
| 5.4 Ventilation | 48 |
| 5.4.1 Natural ventilation | 49 |
| 5.4.2 Dimensioning of natural ventilation | 49 |
| 5.5 Literature | 52 |
| 5.5.1 Sources | 52 |
| 5.5.2 Supplementary literature | 52 |
| 6. Selection of equipment and materials | 54 |
| 6.1 Equipment | 54 |
| 6.2 Floors | 54 |
| 6.2.1 Recommendations for solid floors | 54 |
| 6.2.2 Recommendations for slatted floors | 56 |
| 6.3 Drinking water supply and allocation | 56 |
| 6.4 Materials | 59 |
| 6.4.1 Choice of materials | 59 |
| 6.4.2 Surface treatment | 59 |
| 6.5 Equipotential bonding | 59 |
| 6.6 Cleaning | 61 |
| 6.7 Literature | 62 |
| 6.7.1 Sources | 62 |
| 6.7.2 Supplementary literature | 62 |

| | |
|---|------------|
| 7. Calving section – sucking calfs | 64 |
| 7.1 Calving | 64 |
| 7.1.1 Calving pen | 64 |
| 7.2 Literature | 67 |
| 7.2.1 Sources | 67 |
| 8. Calves and young stock | 68 |
| 8.1 Single housed cattle | 68 |
| 8.1.1 Single pen | 68 |
| 8.1.2 Calf huts | 69 |
| 8.1.3 Stalls | 70 |
| 8.2 Jointly housed cattle | 71 |
| 8.2.1 Joint pen with a layer of litter or deep litter | 72 |
| 8.2.1.1 Litter in the whole pen | 72 |
| 8.2.1.2 Littered resting area and short non-littered feeding area | 72 |
| 8.2.1.3 Littered resting area and long non-littered feeding place | 73 |
| 8.2.1.4 Self-cleaning sloping pen | 74 |
| 8.2.1.5 Joint hut with litter in the total area | 75 |
| 8.2.1.6 Shelter with free access to outside area | 75 |
| 8.2.2 Cubicles | 76 |
| 8.2.3 Joint pen with slatted floor | 77 |
| 8.3 Feeding areas in joint pens | 77 |
| 8.3.1 Roughage and concentrate | 78 |
| 8.3.2 Milk feeding | 79 |
| 8.3.3 Drinking water | 79 |
| 8.4 Literature | 83 |
| 8.4.1 Sources | 83 |
| 8.4.2 Supplementary literature | 84 |
| 9. Dairy cows | 86 |
| 9.1 Loose housing – joint housing | 86 |
| 9.1.1. Housing types – divided into type of resting area | 86 |
| 9.1.1.1 Cubicles | 86 |
| 9.1.1.2 Feeding cubicles | 86 |
| 9.1.1.3 Deep litter | 86 |
| 9.1.1.4 Self-cleaning sloping pen | 87 |
| 9.1.2 Resting area | 87 |
| 9.1.2.1 Cubicles | 87 |
| 9.1.2.2 Resting area with deep litter and separate feeding area | 91 |
| 9.1.3 Feeding area | 94 |
| 9.1.4 Walking alleys | 99 |
| 9.2. Milking area | 100 |
| 9.2.1 Holding area | 100 |
| 9.2.2 Entrance part | 102 |
| 9.2.3 Milking stalls | 103 |
| 9.2.4 Exit part and return alleys | 104 |
| 9.2.5 Hoof bathing | 105 |
| 9.2.6 Separation area | 106 |
| 9.3 Tied-up housing system | 106 |
| 9.3.1 Stall (resting area) | 106 |
| 9.3.2 Feeding area | 107 |
| 9.3.3 Tethers | 108 |
| 9.3.4 Cow control equipment | 109 |
| 9.3.5 Walking alleys | 109 |
| 9.4 Catch-stall housing system | 110 |
| 9.5 Literature | 110 |
| 9.5.1 Sources | 110 |
| 9.5.2 Supplementary literature | 112 |
| 10. Beef cattle | 114 |
| 10.1 Weight and body dimensions | 114 |
| 10.2 Feeding and resting areas | 114 |
| 10.3 Literature | 117 |
| 10.3.1 Sources | 117 |

| | |
|---|------------|
| 10.3.2 Supplementary literature | 117 |
| 11. Outdoor exercise folds | 118 |
| 11.1 Outdoor exercise folds | 118 |
| 11.2 Literature | 119 |
| 11.2.1 Sources | 119 |
| 11.2.2 Supplementary literature | 119 |
| Subject index | 120 |

Introduction

The report has been revised by a work group consisting of specialists within research, education and advisory service. The work group has formulated the aim in this way:

The aim is to point out appropriate equipment and cattle housing system designs as regards animal welfare and working environment.

Target groups

The report addresses the following target groups:

- Milk and beef producers
- Manufacturers of housing equipment and technical aids
- Veterinary surgeons and agricultural scientists
- Construction, production and milk quality advisers
- Researchers and product developers
- Teachers and students
- Politicians and interest organisations.

Structure of the report

The report comprises 11 chapters. Each chapter includes recommendations for housing design on the basis of the animal needs and requirements concerning behaviour, health and other practical matters. First of all the recommendations cover conditions of direct relevance to the animals and / or conditions of directly applicable value, and to a less extent choice of materials and design, etc. Under the sections of "Background and motivation" literature (documentation) concerning the debated, relevant subjects of the chapter is listed. In addition, there is a literature list with sources as well as supplementary literature.

The first chapters illustrate general behaviour, health, supervision and climatic conditions, which should be considered when dealing with cattle.

In respect of dimensioning chapter 2 explains cattle dimensions when standing and lying down as well as when moving dependent on body weight, age and gain.

If nothing else is indicated, the recommended dimensions are for cattle without horns.

Chapter 6 includes some overall functions concerning floors and equipment, which can typically be seen in all sections of cattle houses.

Chapter 7 includes functional requirements and design of calving section.

Chapters 8 to 10 are about functional requirements and solution models for the individual farm sections described for calf houses and young stock houses as well as houses for dairy cows and beef cattle.

Chapter 11 is about design of outdoor exercise folds.

For many designs, layouts and details only a few or none scientific studies has been carried out. Therefore the recommendations are based on practical experiences.

Known housing systems, equipment parts and the like, which the work group does not recommend, are either not included in the report or the report deprecates the application.

No matter how a housing system is designed physical injuries may occur e.g. injuries owing to pressure and injuries to hooves. However, appropriate design reduces the risk.

There are limits to how much "normal" housing design can compensate for secondary physical injuries. Such injuries, which are incorrectly considered to be caused by the housing, can e.g. be due to inappropriate feeding. An example of this can be sore legs caused by laminitis. Cows with laminitis have an unnormally long lying time. When they stand up they relieve the legs by leaning up against the equipment. In this way injuries owing to pressure arise. Cows with laminitis rise slowly and with great trouble and in this way the risk of skidding and teat damage is increased.

All drawings are principle outlines, which support the explanation in the text and the tables.

An example of application

The idea behind the report is to use it as a work of reference.

Housing system, equipment and technical aid developers within cattle husbandry are able to find information on basic requirements for individual functions, hereunder motivation and justification for carrying out product control. Moreover, they can find professionally supported arguments in a future marketing of new solution methods within the field.

Politicians and interest organisations may use the report as reference in dealing with ethic and animal protection dialogues at national and international levels.

Advisers can use the report in the idea and planning phase as a work of reference to inspire and document in connection with elaboration of decision bases for cattle farmers who consider and plan housing building.

Cattle farmers can clarify and support their requirements and on the basis of this control the function in established as well as planned production systems (functional study in connection with quality management).

Lecturers and students may use the report as reference in connection with lectures at schools as well as universities in general.

Indication of dimensions for building and equipment parts

The indicated dimensions concerning the distance between parts of equipment as e.g. the breadth of pens, cubicles, location of neck rail, etc. have been stated as dimensions from mid equipment to mid equipment. Where the demarcation is a solid wall as e.g. a concrete wall the dimensions have been indicated for a solid wall.

Follow up

It is intended to revise the report every few years. Therefore the work group will be pleased to receive suggestions and potential corrections for this edition of the report. Please forward suggestions to the National Department of Farm Buildings and Machinery.

The main feed of cattle is grass and other plants containing cellulose. Originally, cattle were forest animals that went far and wide in the search of feed, water and appropriate places to rest. Cattle belong to the group of light-active animals. This means that the search for feed, social behaviour, grooming, etc. take place during the day, while cattle mainly rest at night. Finally, cattle are gregarious animals.

The knowledge of the normal behaviour of cattle mainly derives from wild domestic cattle, beef cattle or crossbred beef cattle kept under natural or half natural circumstances. Most results concerning behaviour in intensive production systems derive from our modern dairy cattle breeds.

Intensive production and housing systems are characterised by a high degree of mechanisation, high animal density, and low performance. Thus it is not always possible to satisfy the basic needs of the animals in such systems, and they cannot be adapted to the environment. This results in behavioural changes and a high risk of physical injuries and diseases.

1.1 Cattle senses

All the senses of cattle are well-developed and are applied both in the search of feed and as a mean of orientation and social communication.

The range of vision of cattle covers 330-360°, and the field of vision covered by both eyes at the same time is 25-30° (figure 1.1). Cattle are able to distinguish between the colours red, yellow, green and blue, however, the distinction between green and blue is poor. Cattle are able to distinguish between differently simple shapes such as triangles, circles, and lines. The ability of cattle to focus is probably poor, too.

It is more likely for cattle to move from a dark area to a light area than the other way around. However, they are cautious about entering strong daylight, and they avoid strong contrasts between sun and shadow, e.g. sun/shadow from a railing or a window.

The hearing of cattle (frequency range) is almost the same as the hearing of persons, but they are actually able to pick up some high tones that we cannot hear. However, cattle are not good at localising sounds, as they are only able to determine the source of the sound within a range of 30°. Thus cattle are restless when they are not able to "see" where the sound is coming from. The sense of smell is well-developed and it is utilised frequently when cattle seek food and when they communicate socially. The bull is able to detect a cow on heat several days before she is really on heat by smelling her. Moreover, a cow finds and recognises her calf by means of her sense of smell.

The sense of taste is important as regards the choice of feed. Cattle prefer sweet and sour feed, while they refuse bitter feed and feed containing much salt. The sense of touch is also well developed on the naked muzzle as well as on the body. It is assumed that physical injuries, lesions, diseases, and stress are experienced as pain and malaise by cattle as by people.

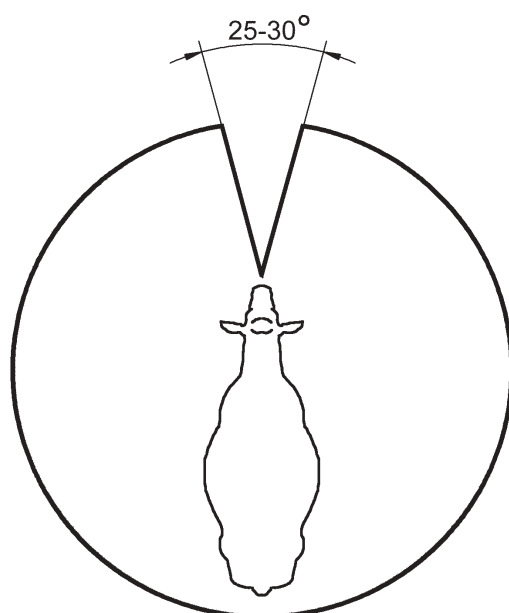

Figure 1.1.
Range of vision
of cattle.

1.2 Social behaviour

Any manifestation of life between conspecifics is social behaviour. Just like all other gregarious animals, cattle have a well-developed social behaviour, which can be divided into aggressive behaviour (e.g. battle, threats) and non-aggressive behaviour (e.g. social grooming).

1.2.1 Communication

Cattle communicate by sending out different signals. The signals are poses, sounds, and smells, and the signal is picked up as a visual, sound, scent, or touch impression.

Through generations a genetic basic for the performance and interpretation of the individual signals has been coded in such a way that all individuals within the breed master this way of communicating. However, most behavioural patterns require some sort of learning and training in order to be able to carry out the behaviour correctly. The learning might be attached to certain periods of the animal's life, and if this learning is prevented, problems of communicating might arise.

Calves that are bred isolated during the first two to three months of life will later on find it difficult to socialise with other calves. The lack of social contact is presumably a strain on the animal. Even calves that are kept in closed single pens that make it almost impossible to see or touch other calves most often have a high frequency of "licking itself behaviour". This behaviour is increased further when calves are kept in pens without litter and fibre-rich supplementary feeds.

1.2.2 Individual distance requirements

The distance between conspecifics (the individual distance) can be divided into a physical and a social room (figure 1.2). The physical room constitutes the space, which the cow needs for its necessary movements, e.g. to lie down, get up, stretch, etc. The social room is the minimum distance, which the cow keeps to conspecifics.

If the minimum distance is overstepped, the cow will either try to escape/run away or it will behave aggressively. The "personal" minimum distance of the cow to other individuals is limited by a circle around its head, because cows

orientate themselves through the sense impressions they receive through the eyes, ears and smell. The individual distance is thus always measured from head to head. The individual distance for adult cows at pasture is, typically, two to four meters. Moreover, the individual distance is very activity dependent. Polling limits the individual distance, and in certain situations, e.g. when cows lick and rub each other for social reasons, the distance is of course zero.

A high density of animals limits the freedom of movement of the cow and if this is repeated, social stress may occur. Investigations of heifers and young bulls on slatted floors have shown that an increased density rate results in more aggressive clashes and a high frequency of undesirable behaviour. In another investigation the frequency of undesirable behaviour (tongue rolling and other oral activities directed at objects or other cattle) rose 2.5 - 3.0 times among young bulls when the density rate was increased from 2.3 m²/animal to only 1.5 m²/animal. Troubles caused by heifers on heat also increased at 1.6 m²/animal compared to 3.0 m²/animal, especially, because the frequency of mounting rose. Less physical space also results in a situation where a large number of cattle are urged to stand up due to disturbances of other cattle in the group.

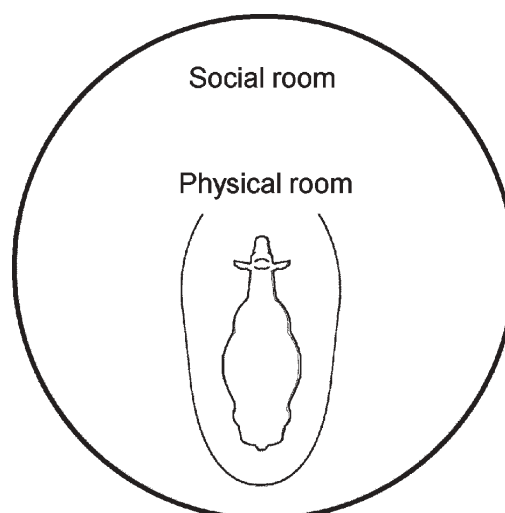

Figure 1.2.
The physical and social room of cattle (individual distance).

Chapter 1

A reduction of the walking width between dairy cow cubicles from 2.0 metres to 1.6 metres resulted in a high degree of aggression, and "queuing" between the feed alley and the cubicles. The cubicles were frequently used as "passing place" and "turning area", because cows were unable to pass each other without touching each other (the individual distance was overstepped). "Blind passages" cause huddling and increased aggression among cattle.

The abnormal getting up and lying down behaviour will increase, if the physical space is limited, and the resting time is reduced if the animal density rate is high. The increase of the abnormal getting up and lying down behaviour is one of the reasons why the frequency of tail treads raises on slatted floor.

Examinations show that a high degree of e.g. young stock kept in group pens will strain animals to such an extent that it might affect both their welfare and yield negatively.

The necessary number of animals per m² does of course depend on the size of the young animal.

1.2.3 Ranking and rank criteria

Under natural conditions cattle form small herds consisting of a bull, cows, young animals and calves. Young bulls of more than 10 – 12 months are chased away from their herd. The dominance relations are determined on the basis of the social behaviour, and a rank order (hierarchy) is build, so that each individual "knows its place" in the herd. The dominance relations are gradually established during adolescence. The ranking is often very stable in intact groups, and in this way the herd is able to live in harmony.

In order to maintain the stable rank order, and avoid trouble and unnecessary aggression in the herd, the change of individual cows has to be limited as much as possible. However, if a change of animals must take place, it is best to move several animals than one at a time.

Rank orders are prevalent within each group of dairy cows, heifers or fattening animals that walk freely together in e.g. loose housing systems. The ranking of each animal depends on its age, weight, seniority and temperament.

In this way old and big cows always have a high ranking, while young, light and newly arrived cows – primarily first calvers – will have a low ranking in the hierarchy. Thus young, small and newly arrived cows will have poor production conditions in loose housing systems, especially if the conditions are not optimal.

If a few animals have been isolated from the group for a long time, or if the herd has been kept in tied-up housing systems during the winter period, the hierarchy must be re-established. The hierarchy can be maintained for years without any clashes in the form of physical fighting, if the cattle have access to physical contact regularly. Fairly few situations of threaten and retreat behaviour are sufficient to maintain the rank order.

Not much research has been done in optimal group size. It is assumed that the maximum number of animals that a cow is able to know is 70 – 80. The risk of clashes increases, if the herd is bigger, because the animals do not recognize each other. The optimal group size of calves and heifers is unknown.

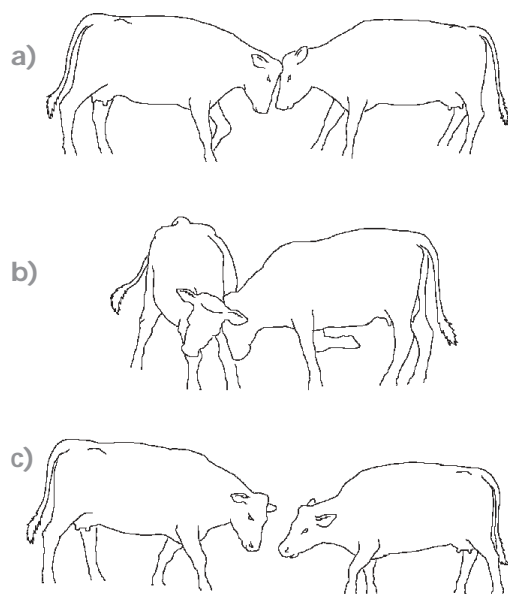

Figure 1.3.
Physical fights and threats. a) frontal fight, b) brow push from the side, c) threat (psychical).

1.2.4 Aggressive behaviour

Directly aggressive and physical contacts primarily arise during the establishment of the rank order. Frontal fight (forehead against forehead) is most aggressive, however, brow push against shoulder and flank can also be very violent (figure 1.3).

Once the rank order has been established, the threatening behaviour is dominating. The aggressive threatening behaviour can be intensified by pushing and tossing the head against the opponent. If resources such as feed, water, lying areas, etc. are limited, the aggressive behaviour will rise considerably and it may be very violent.

A clear understanding of the actual needs of the animals is often necessary in order to comprehend the situation – the limited resource. Intensified aggression among heifers in a - by normal standards - very big community pen may for instance be due to the fact that the littered lying area is too small, or when fed restrictively the feeding place is too little.

1.2.5 Social grooming

Cattle have a distinct urge to lick and be licked by their peers. Thus the licking behaviour must be regarded as a normal behavioural manifestation.

When the social grooming takes place among cattle, the individual distance is ignored and there does not arise any aggressive actions. The active animal always approaches from the front, and in order to avoid escape or aggression, the characteristic *approaching attitude* is performed with stretched neck, lowered head and extended muzzle. If the passive animal does not wish to be contacted, it will conduct a deviant and threatening behaviour, but it rarely attacks. If the active animal wants to be licked, it will keep its approaching attitude in front of the selected partner and the behaviour will change to an *encouraging attitude*. If both animals wish to be licked they may keep the encouraging attitude in front of each other for a while. The animal of the highest rank may emphasise the invitation by pushing its muzzle against the underside of the partner's neck or by soft forehead pushes.

The invitation can also be initiated by means of a *social battle-like game*, in which the two animals will mutually rub each other's head and forehead. The behaviour often results in mutual social licking of the face, ear and neck.

Social grooming almost always starts out by the head or the neck, and afterwards the animal will change its position in order to have other parts of its body licked (figure 1.4). It will often turn those parts of the body towards its partner, which it cannot reach by its own tongue. Thus the muzzle, tip of the tail and limbs are not licked. The choice of partner for the licking process is rarely random, as many cows prefer the same partner each time.

All the animals of the group are licked, but not all the animals lick. Animals of similar rank lick each other more often than animals of very different rank. Moreover, social licking is often carried out, when a change of activities takes place, e.g. before or after a rest, and when cattle have been disturbed and this has caused unrest (calming effect).

Cattle need social grooming, and if this need cannot be met, e.g. because the animal is tethered, the need is accumulated and will result in an intensified grooming activity, as soon as the possibility offers itself again.

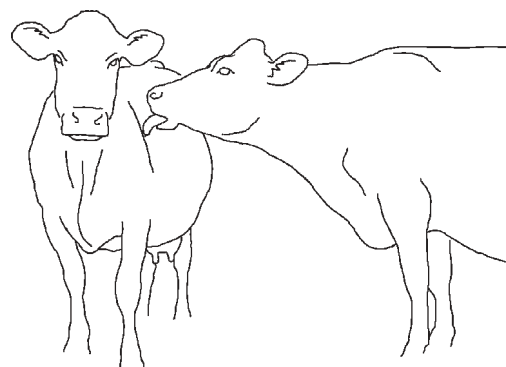
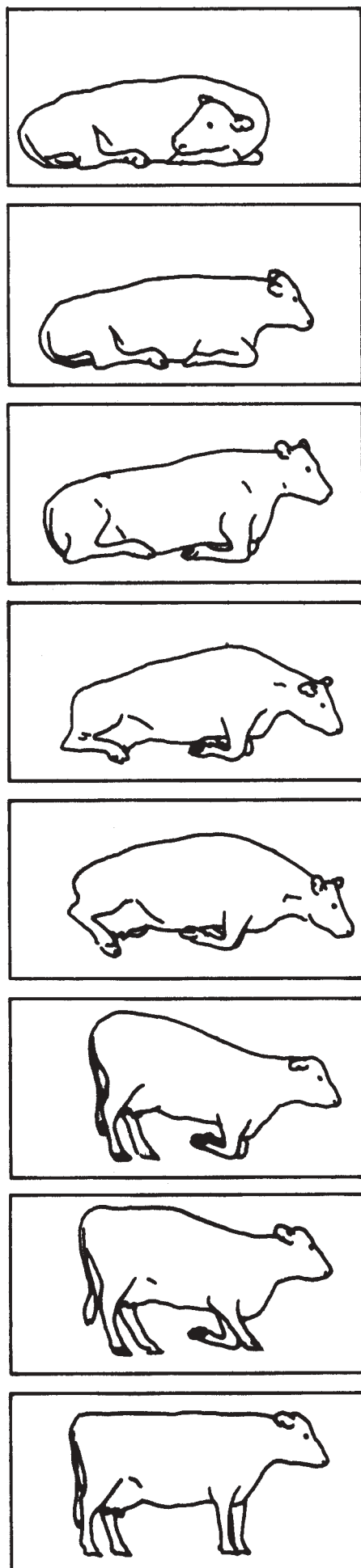

Figure 1.4
Social grooming.
Cattle have a distinct urge to lick and be licked by each other. Social licking contributes to maintaining the social hierarchy.

Chapter 1



1.3 Circadian rhythm and activity patterns

Cattle have a distinct circadian rhythm, in which the main rest, feed and rumination activities vary according to a fixed pattern (see these). At the same time cattle are gregarious animals and thus a group of cows or heifers will prefer to carry out the same behavioural activities at the same time. This circadian rhythm is difficult to change and hence problems may arise, e.g. in connection with automatic milking or reduced feed alley, which are based on an individual behavioural pattern.

1.3.1 Lying time, lying frequency and circadian rhythm

Lying has a very high priority among cattle. Calves lie down 16 – 18 hours per day distributed over 30 – 40 periods. The lying time of cattle decrease with age and thus a cow normally lies down for 10 – 14 hours distributed over 15 – 20 periods. Cattle doze (light sleep) more than they sleep. They are able to stand up and ruminate while they doze. Cattle only sleep a couple of minutes 10 - 15 times per day. The long rest periods include rumination as well as doze and profound sleep.

The lying periods of cattle are fit in between the periods of feeding and standing. A lying period typically lasts for half an hour to three hours. During the long lying periods – in the middle of the day or during night – the cow rises, stretches and lays down immediately again, usually, on the other side. Thus cattle spend more than half of their lives lying and during a whole year a dairy cow lies down and rises 5,000 – 7,000 times. Among other things the lying time and the number of lying periods depend on the age, heat cycle and the state of health of the cow. Moreover, the weather, the quality of the bedding, the type of housing and the number of animals per square metres also influence the lying time and the number of lying periods.

1.3.2 Lying down and getting up behaviour

The natural lying down behaviour of cattle begins when the animal sniffs at the ground while it slowly moves forward (in search of a suitable place to lie down). When the cow has found a suitable place, it, characteristically, shuttles its head from one side to the other to

Figure 1.5.
Natural getting up
behaviour among
cattle.

examine the place. Afterwards, it bends its forelegs, kneels and, finally, it carefully moves one hind leg under its body and lies on it. The lying down behaviour requires much space in order to be carried out normally. The head and body of a fully developed cow is thrust 0.60 – 0.70 metre forward during the lying down process.

When a cow wants to get up in a natural way it firstly rises to its knees and afterwards the hind part of its body is swung up via the knees, which functions as rocking point (see figure 1.5). This movement is one of the greatest physical activities of cattle. The natural lying down behaviour is a reverse frequency of the movements of the natural getting up behaviour.

In the open cows often carry out the lying down and getting up activities in one continuous movement. When cows are kept indoors their movements may be hampered by too little space, tethering and/or hard and slippery flooring. In this way the movements may be abrupt several times at different behavioural stages, or the behaviour may be carried out abnormally (figure 1.6 and 1.7). Thus the frequency of abnormal lying down/getting up behaviour is higher when cows are kept on slatted floors than deep litter, and the frequency rises according to age. Each lying down/getting up behaviour may last for several minutes instead of the usual 15 – 20 and 5 – 6 seconds respectively. At the same time there is a higher risk that the cow injures itself physically.

1.3.3 Lying down positions

Normally, cattle lie with their head erected, resting on the sternum and either the right or the left thigh (see figure 1.8). The head is raised and the two forelegs may be either stretched or bended. Rumination when the cow lies down always takes place in this position. We have knowledge of three typical "resting" positions:

- The head is bended backward, so that it rests on or lies along the body (most frequent)
- The head is stretched forward and chin rests on the bed (frequent)
- The cow lies flatly stretched out completely on the side (frequent).

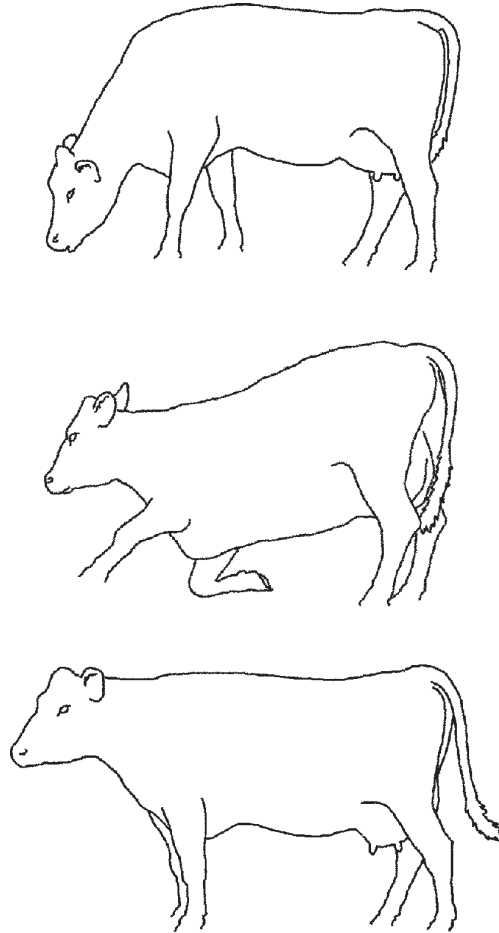

Figure 1.6.
Abnormal lying down behaviour. The cow bends down on one or both knees after which the behaviour is interrupted, and the cow gets up again and stands on all four hoofs.

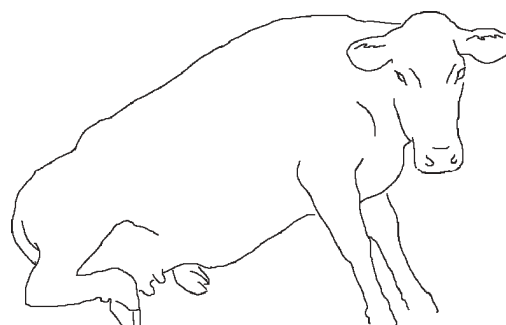
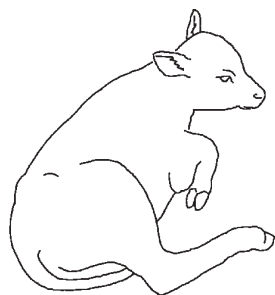
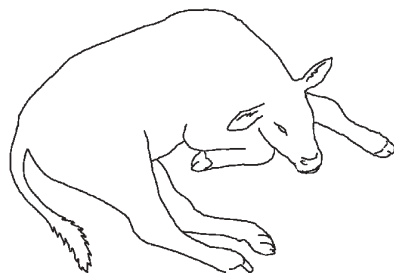

Figure 1.7.
Abnormal getting up behaviour. The cow rises like a horse.

Chapter 1



Normal position



Normal position with stretched legs

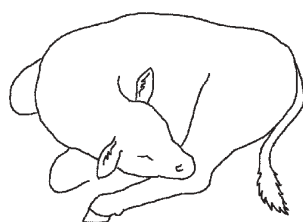

Head resting on body



Head resting on bedding

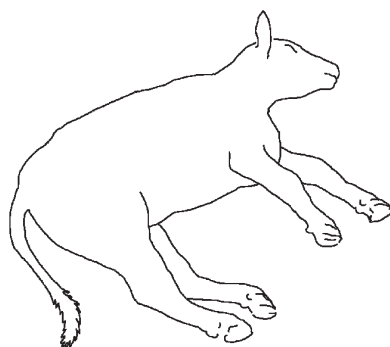

Lying flat on the side

The durability of the two last-mentioned positions is, however, short. The "resting" positions are assumed 30-40% of the resting time of calves and 15-20% of cows. Deep sleep occurs only when the cows assume their lying down positions. Many cows of tied-up housing systems have difficulties in taking up a normal "resting" position due to the tether and the feed alley design. This situation may influence the resting need and the lying down behaviour of the animals.

1.3.4 Choice of lying place and bedding

There has not been carried out much research in the choice of lying place at pasture. However, cows have a tendency to choose high-lying and wind-swept places when the weather is warm, whereas sheltered places are preferred when it is cold. Normally, when the first cow of the herd has assumed its lying place, the other cows take up places nearby. Typically, cows will lie with intervals of 3-5 meters between their heads.

In housing systems cattle always choose a soft to a hard and slippery bedding. The level of skid resistance, hardness and workability of the bed has a great influence on the lying down behaviour. Several examinations have shown that the number of lying-down periods is reduced on slatted floors compared to deep litter bedding, because the motional pattern of cattle is restrained.

If heifers can freely choose between deep litter bedding and slatted floors, they will prefer deep litter. Dairy cows in cubicle houses choose soft, heat-insulated mats to hard rubber mats. However, a nicely made straw bed always has the highest priority among cattle.

Cubicles with draught and noise are often avoided. Moreover, the neighbouring cubicles of a cubicle with a dominating cow are unattractive. In connection with rapidly growing young bulls, slatted floor may cause a change of motional pattern and painful joints due to the smoothness and hardness of the floor.

Thus it can be concluded that housing of young stock on fully slatted flooring restrains the motional pattern of cattle to such a degree that the frequency of the performance of the lying down, comfort

Figure 1.8.
Different lying positions among cattle.

and social behaviour is changed considerably. Thus the welfare of cattle must be regarded as reduced.

Cows have a relatively constant need to lie down and this behaviour has a high priority. If the lying down behaviour is prevented – even for a few hours – the need to lie down rises and exceeds the basic needs, e.g. the eating need. Less than one cubicle per cow will reduce the lying down time of the cows and increase cases of abnormal behaviour.

Deep litter housing is a very “free” housing system in which cows can perform almost all their normal behavioural activities naturally. The only restricting factor in connection with deep litter mats is the animal density rate (m^2/cow). A high density will cause a higher level of trouble and aggression among cattle.

1.3.5 Movement

Cattle need space for movement and frequent exercise in order for their muscles, sinews and bones to develop normally. If they are not exercised properly it will be difficult for them to lie down and get up. They will develop an unsteady gait and it will be difficult for them to coordinate their movements.

It has been shown that calves housed in small single pens will be more motivated to run and jump/kick, the longer it is since they have had a chance to exercise. The solution to this problem is to give calves frequent access to an exercise fold or to house them in large group pens.

If tethered cows are at pasture for 5-6 months per year, the risk of developing more production diseases such as mastitis, teat damage, retained placenta, milk fever and ketosis will be reduced and the possibility of improving the reproduction ability increased. Even a relatively short period of daily exercise (2-4 hours) seems to have a positive effect on the reproduction ability, the frequency of retained placenta, milk fever and ketosis.

Grazing in the dry period does also seem to have a favourable effect on the reproduction in the succeeding lactation. Naturally, rearing in loose housing system pens with a high animal density does not provide a sufficient freedom

of movement, nor has it been proved whether the exercise need is considered in dairy cow cubicle housing systems. Typically, dairy cows at pasture walk 3-5 kilometres per day. However, this depends on the amount and the quality of the grass and the size of fold. In loose housing systems with access to an outdoor run the daily walking distance is about 1 kilometre.

The tying up of cows and heifers all year round poses behavioural and health problems to the animals.

1.4 Comfort behaviour

The term comfort behaviour covers all kinds of behaviour that increase the physical well-being of cattle. Grooming is the most important activity, however, stretching and shaking of oneself also belong to the comfort behaviour of cattle.

The function of grooming is to remove droppings, urine and parasites and keep up the skin and the fur. When the animal performs the grooming behaviour it partly licks all the places of its body that it is able to reach with the tongue, partly rubs its body against objects or scratches itself with the back hoofs (see figure 1.9). Tosses with head,

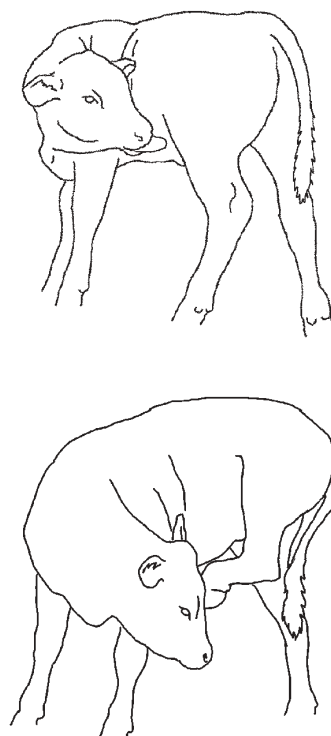

Figure 1.9.
Grooming behaviour a) licking the udder, b) scratching with hind hoof.

Chapter 1

tail or legs against the body are carried out to chase away flying insects. The weather and the amount of parasites affect the grooming behaviour. Often the grooming behaviour takes place in connection with a change of activities, e.g. right before or after rest.

The first weeks after birth, the cow performs the grooming of the calf. Thus the calf does not lick itself very often during that period of time. Older calves use 4 – 6% of the day and night on grooming activities, while full-grown cows only lick and scratch themselves about 1% of the day and night. The frequency typically varies from 10-15 to more than 100 times per day. The grooming behaviour is distributed as follows:

- 60 – 70% licking
- 10 – 30% rubbing against object
- 1 – 3% scratching.

It is assumed that grooming is primarily motivated by external stimuli, i.e. something that annoys the skin. Skin parasites such as vermin, lice and ringworms are very annoying for animals and must be treated fast and efficiently.

However, increased grooming behaviour can also arise in conflict and frustration situations that strain the animal. Increased grooming is frequent among tethered animals, animals in new surroundings (adaption problems) and isolated animals. A tendency to slip is often seen in connection with the performance of grooming and social behaviour on slatted floors and concrete floors without litter, but never on floors with deep litter. Finally, it should be mentioned that the frequency of social grooming can affect the grooming behaviour of the individual animal.

1.5. Feed and water intake

The feed and water intake of cattle are interdependent. Feed with high water content lowers the need for water intake. Insufficient water supply influences the feed intake and thus reduces the yield.

1.5.1 Grazing and circadian rhythm

The grazing behaviour of cattle is rather monotonous. Cattle slowly move over the field with the muzzle close to the ground while moving the head from side to side. As the animal at the

same time leans a little forward on the front leg, the front part of the animal is lowered about 5 centimetres. Thus the animal is able to reach the ground with its muzzle.

By means of the tongue, the front teeth of the lower part of the mouth and the dental plate of the upper part of the mouth, the grass is gathered and cut off. It is difficult for cattle to get hold of vegetation lower than 3 centimetres. The vegetation is chewed slightly before it is swallowed together with added saliva. By means of smell and taste senses a certain selection of the grass takes place during the intake.

Cows eat grass 5 – 9 hours per day during which they walk 3 – 5 kilometres. The duration of the grazing time primarily depends on the weather, the quantity and the quality of the grass. Bad weather characterized by continuous rain and wind reduces the grazing time. The application of supplementary feed has the same effect as bad weather. On the other hand a poor grass quantity or grass with a high content of cellulose will increase the grazing time. Moreover, the individual grazing time and grass intake may vary considerably.

Cattle are gregarious animals and they prefer to eat at the same time. The circadian rhythm at pasture is typically cyclical with 4 – 5 grazing periods per day, interrupted by resting and rumination. The main intake takes place during two long, intensive grazing periods; one around sunrise and one around sunset. Between these two periods 2 – 3 short and less intensive grazing periods will take place during the day according to the season. During the summer months 85% of the grazing will take place during the day. However, as the days get shorter, the cattle will graze more and more at night.

Naturally, the milking of dairy cows will be incorporated as an established part of the circadian rhythm. If the milking in the morning takes place before sunrise, the first period of grazing happens after milking. If the cows are milked late in the morning, they will start grazing before they are driven in. The second, long grazing period always takes place after the evening milking.

1.5.2. Feed intake in housing systems

In the housing systems the cow normally places both forelegs next to each other while it eats and thus it does not lower the front part of its body. This means that the cow has difficulties in reaching feed at ground level. Several examinations have shown that there is an upward tendency towards physical injury occurrences when the feed alley is this low. Thus the feeding level should always be raised 10 centimetres above the level of the cow's forelegs. The feeding area of the dairy cow is within 0.60 metres from the rear edge of the trough, as it cannot reach any further.

The feeding rhythm of the cows follows the daily feeding hours. When feeding takes place twice per day – morning and late afternoon – the main part of the feed intake will take place at these hours. The feeding time will normally decrease (4 – 6 hours/day), and the number of feeding periods increase (6 – 12 periods/day) when the cows are fed in the cow house and not at pasture. This is because the feed is partly close to the animal and partly easily accessible.

At some points of time first calvers, old, walking-impaired, down-calving and high-performance cows may not eat as much as usual due to “bullying” or due to their own inclination. Other cows of the herd may take advantage of this situation and eat a larger amount of feed than usual.

1.5.3 Restrictive feeding

When a limited amount of feed is spread at a joint feed alley, most of the feed is eaten in short time. Enough space at the feed alley is therefore decisive for a uniform feed intake. If there is a shortage of feeding places (less than one per animal) there is a risk that low-ranking cows will be pushed away from the feed alley. Thus the total feeding time of low-ranking cows will be shorter than the feeding time of the rest of the group. Even if there is a feeding place per cow, an increasingly uneven growth and milk yield must be expected among young animals and cows, when restrictive feeding makes up a considerable amount of the feed ration. Any kind of separation at the feed alley (trough partition) will protect the animals while they eat and reduce the individual variations.

1.5.4 Ad lib feeding

It is possible to increase the number of animals to 2 – 3 per feeding place (0.25 – 0.35 metre feeding space per animal), if cattle are ad lib fed in loose housing systems, in which cattle have access to feed during most hours of the day. The feeding time will decline, but apparently not the feed intake. However, a number of examinations have shown that the competitive situation of this high rate of animals per feeding place will strain the lowest ranging animals.

1.5.5 Rumination

The rumination starts relatively soon – ½-1 hour – after the grazing or feed intake has ended. Rumination consists in regurgitation from the rumen of partly chewed feed, which is then chewed completely by the back teeth while the lower jaw moves from side to side. After regurgitation the liquid part of the “ball of cud” is swallowed, while the solid parts are chewed 50 – 60 times and, finally, added with saliva swallowed.

Usually, cows ruminate 5 – 8 hours per day spread over 15 – 20 more or less limited periods of time. Each period of time lasts from a few minutes to approx. one hour. Most of the rumination takes place while the cow is lying down (70 – 80%).

The rumination time depends very much on the structure of the feed. A structureless and easily digested feed reduces the rumination. Thus the saliva mixing is reduced in such a way that rumen disorders (rumen acidosis, displaced abomasums) and pseudo rumination may arise. Disturbances reduce the rumination and hence the feed intake.

1.5.6 Water intake

The daily water need of cattle depends on the air temperature and the production. In Denmark dairy cows take in 30 – 100 litres of water per 24 hours. Feed with a high water content reduces the need for drinking water. At pasture the cows take in water 2 – 5 times per 24 hours depending on the distance to the water. If cows have to walk several kilometres, they will only drink once or twice.

In tied-up housing systems in which the automatic water trough is placed right in front of the cow, cows often take in water 15 – 20 times per 24 hours. Since

Chapter 1

cows normally take in water under or right after they have been fed, several automatic water troughs are required in loose housing systems, so cows have several options. The drinking speed of dairy cows is 10 – 20 litres per minute, if the surface of the water is free. Cows take in most water at a water temperature of 15 – 20°C, which also has a positive influence on the milk yield. Cattle suck in water and they prefer to do this from a free water surface.

1.6 Reproduction

The sexual maturity of cattle sets in when the animal is 6 – 12 months old depending on the breed and the environment. The sexual activity is very little prior to the maturity. However, bull calves may already show an interest in cows on heat from the age of four months. Under natural conditions mature young bulls would brake away from the herd and live alone or in small groups. In intensive production systems the sexual activity of both bulls and heifers of big dairy breeds increases at a weight of approx. 300 kg, which normally corresponds to a 7 - 8-month-old bull and a 13 -15-month-old heifer.

1.6.1 Sexual behaviour of bulls

Normally the sexual behaviour of mature bulls in loose housing systems consists of the following elements: Courting, erection, mounting, ejaculation and dismounting.

The courting of the cow starts two days before it is on heat (oestrus). Gradually, as the cow comes nearer to oestrus the bull's interest and pursuit of the cow gets more and more intensive. Often the bull sniffs at the outer genital organs of the cow after which it in a typical movement lifts its head and turns out the inside of its upper lip – flehmen behaviour. Before the bull mounts the cow, it places its head and neck against the loin of the cow, which stimulates the cow to stand still. As the bull mounts the cow, the penis is led into the vagina of the cow and the bull ejaculates, when the penis is led to a maximum into the vagina. Thus actual mating movements do not occur as they do when e.g. horses and pigs copulate. This behaviour makes it easy to collect bull semen.

As the bull perceives and is stimulated by the cow on heat by means of its

sense of smell, all young bulls who are in the same barn as a cow on heat will show sexual excitement perhaps with subsequent ejaculation. This excitement can be reduced by fattening the young bulls, if they are kept in a separate barn. Young bulls in loose housing systems often mount each other, which may cause some unrest and a reduced body weight gain.

1.6.2 Sexual behaviour of cows

The sexual behaviour of cows and heifers is limited to the period of heat, which is stimulated by oestrogen from the ovary's follicles. During the mating period the physical activity of the cows and heifers rises considerably. The normal feeding and resting time is reduced considerably, too, while the standing and walking activities rise and cows and heifers are very restless.

The social order of precedence is interrupted as cows on heat threaten both dominating and subordinate herd members.

A cow on heat accepts that other cows mount, which is an abnormal behaviour of a cow that is not on heat. Only about one fifth of the cows that are not on heat on the farm will show an interest in a cow on heat. This small group of cows changes depending on the cow on heat.

The most characteristic changes of behaviour of cows on heat are restlessness, lowing, reduced feed intake and a readiness to be mounted. One push with the hand on the rear end of the cow's back will cause the animal to sink down its back and lift its tail and lumbar region. It is important for the farmer to notice this special behaviour of the cow, especially on farms where the cows are not served naturally.

1.6.3 Calving and the cow's behaviour towards the calf

Cattle belong to "lying out" or "hidlers". This means that the new-born calf is left behind when the cow leaves to drink or feed.

Examinations of cattle show that the behaviour of cattle changes the last couple of days before the calving. The cow gets restless and it does not carry out the same activities as the rest of the herd. In areas with trees and bushes the

cow will seek remoteness when the calving is near. It would thus be in accordance with the natural behaviour of the cow to put it in a calving pen and separate it from the rest of the herd. Most cows lie down about half an hour before the calving, and during the second stage of labour the cow normally lies on the side. Most cows lie down during the whole calving. However, beef cattle often get up when the head and front part of the calf appears and stand up during the rest of the calving.

The course of the calving depends on the age of the cow. The calving of first calvers lasts longer than the calving of older cows and similarly first calvers also lie down for a longer time after the calving than cows that have had three or four calves. Generally, it takes a little longer for dairy cattle to get up again after the calving than beef cattle.

The cow reacts by making faint, deep sounds when it sees the calf and will in most cases begin to lick the calf intensely right away. Thus the cow must never be tied up during or after calving unless the calf is removed immediately after birth. Older cows with experience from previous calvings will start to lick the calf right after birth while first calvers might be aggressive towards and hesitant about the calf at first.

The cow energetically licks the calf's head, shoulders, back and loin during the first couple of hours after the calving. The cow gets to know its calf by licking it. Thus this behaviour is an important basis for the binding between cow and calf (figure 1.10). Later on the cow will probably recognise the calf by means of its sense of hearing and smelling. During the short period of time after the calving in which the binding (imprinting) takes place - during the so-called sensitive period - the cow is highly sensitive to visual, odour and sound impressions from the new-born calf.

The cow stays together with the calf until it has sucked milk from its teats for the first time. During the first couple of days the cow spends much time together with the calf, but it leaves the calf behind when it leaves to drink or graze. During the first couple of weeks after the calving it is the cow that seeks out the calf so that it can suck milk from its teats. Later it is the calf that

seeks the cow when it is hungry. Thus it must be assumed that the need of the cow to have its teats sucked/milked decreases in the course of time after the calving. The cow defends the calf and its territory from the other cows. Normally, the placenta comes out of the cow a couple of hours after the calving and the cow often cleans the calving place by licking it and eating the foetal membrane.

1.6.4 Behaviour of calves

A few minutes after the calf is born, it starts to raise its head and after a couple of attempts it succeeds in resting on its sternum. The calf immediately attempts to get on its feet and often it succeeds within half to one and a half hour. Calves that are born on a soft bed (grass, straw, etc.) will get on their feet quicker than calves born on a hard bed. Moreover, beef breed calves will get up sooner than dairy breed calves.

As soon as the calf can stand on its feet, it starts to search for the udder and teats of the cow. Calves have a natural instinct for putting their muzzles up under the stomach of the cow and search for its teats at the highest level. Often the calf places itself in the opposite direction of and parallel with the cow. It spreads its forelegs and sinks its

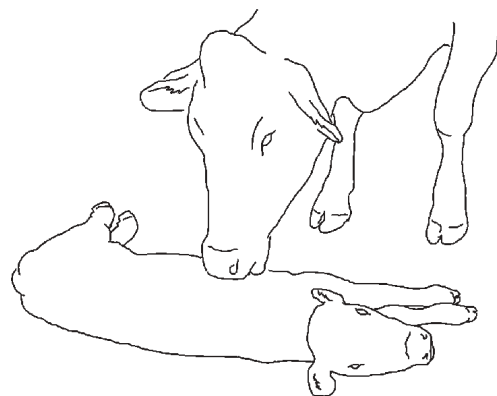

Figure 1.10.
The cow licks the new-born calf and thus the blood circulation of the calf and the faeces and urination is initiated.

Chapter 1

shoulders, which makes it easier for the calf to reach the udder in the search for the teats. As soon as the calf finds the teats it starts to suck milk. During the sucking the calf will with short intervals push its head and bridge of the nose characteristically against the udder of the cow.

Most calves will succeed in sucking milk before they are 3 – 5 hours old. However, this differs considerably according to individual and breed. The most important reason for this is the different udder forms of cows. A big and hanging udder will change the form of the abdominal line, so that the udder will no longer be placed at the highest level. Several examinations have shown that for this reason up to one third of the dairy breed calves do not succeed in sucking milk within the first six hours. Thus in order to be sure that the sucking calf obtains colostrum at an early stage it is best to help the calf during its first sucking, so that they will soon be able to stand up. As soon as the calf has learned how to find the teats, it will not forget this. In large joint calving pens with several cows and calves some of the calves may suck milk from other cows than their mother.

Calves are born without any antibodies to protect them from infectious diseases. During the first two to three weeks the immune response thus depends totally on the antibodies (immunoglobulins) that are supplied by the colostrum. Therefore it is important that the calf is supplied with colostrum quickly, because the immunoglobulins content of the colostrum is highest right after the calving after which it gradually decreases. Moreover, the ability of the epithelium of the gut to absorb antibodies is highest during the first 6-12 hours after calving. Usually calves kept together with the cow will obtain a higher immune response level than calves that are fed colostrum from a bucket or an artificial teat, provided that they start to suck early.

1.6.5 Sucking and eating behaviour of calves

During the first week after the calving the calf will suckle milk up to eight times per 24 hours. Subsequently the frequency of suckling periods decreases with age. Up until the age of two months the calf will typically suckle

milk four to six times per 24 hours, from the second to the sixth month three to five times, while six to eight-month-old calves only suckle milk in the morning and evening. The suckling of beef cattle is often naturally connected to the circadian rhythm of the cow.

Thus the calf suckles the first time around sunrise when the cow gets up after a night's rest – but before it starts to graze. During the day the calf suckles two to four times and, finally, it suckles one last time before the cow goes to sleep. The calf rarely suckles during the night. Each suckling period lasts from eight to 12 minutes. Beef breed calves will often change teats and push their heads more often against the udder during the last phase of suckling than dairy breed calves. This behaviour is probably due to the lower milk yield of beef cattle. During each period the calf suckles milk from the cow, the calf will normally only use two or three teats and among beef cattle the teats used will usually be milked dry.

The sucking need of the calf is often very high during the first four to five weeks. When the calf drinks or suckles milk, the need to suck will increase and it will peak after five to six minutes. This need will then gradually decrease during the next half hour. When the calf suckles milk from the cow, it will suckle so much that its sucking need is met. Those calves whose sucking need is met will only very rarely suck on other calves or the equipment after the intake of milk.

When the calf is bucket fed the milk is drunk rather than sucked. Often the milk intake ends when the sucking motivation has reached its peak (after three to four minutes). Subsequently, the sucking behaviour is directed towards equipment and calves near by. Especially, ears, legs, scrotum, penis and mouth are sucked. This kind of suckling substitution is most frequent during the first two months of the calf's life. This behaviour may lead to an abnormal sucking behaviour on foreskin/penis, which may result in urine drinking, which is injurious to the animal. This disadvantageous sucking behaviour, which is due to an unsatisfied sucking need, can be reduced considerably by mounting an artificial teat in the calf pen next to the milk bucket.

After the calf has finished drinking the milk, it will suck on the artificial teat and thus its sucking need will be met. An abnormal sucking behaviour of the calf may be maintained also later on during the rearing period.

When milk is supplied by means of a teat feeding system the sucking need of the calf will to a higher degree be met during the intake of milk than when the calf is fed milk from a bucket. Thus the abnormal sucking on other calves and/or equipment will be reduced considerably. However, the calf should be adapted to the teat feeding system during the first week after it is born, as its natural instinct to seek for the teats will disappear after three to nine days. Calves, which have been fed from a bucket up till this time, will have difficulties in learning to drink from a teat feeding system.

Calves, which are at pasture together with their mothers, will already during the first or second week of their lives start to eat – nibble - blades and leaves of grass. When they are six to eight weeks old they are fully developed ruminants. An early intake of fibre-rich supplementary feeds is necessary in order for the calf to quickly develop a cud-chewing function and thus reduce the risk of developing digestive disorders. When the calf is about three months old, it is able to adapt the grazing pattern of the herd. However, calves will usually graze together until the age of five months.

During the period when calves feed on milk they also need water whether they are fed milk from artificial teats or from a bucket. The best way to ensure the water supply of calves is by means of a free water surface.

1.6.6 Separation and weaning

Under natural conditions weaning takes place when the calf is eight to 15 months old or at the next calving at the latest. On most beef cattle farms the cow continues to nurse the calf until it is approx. six to eight months old after which it is weaned. In contrast, calves on dairy cattle farms are removed from their mother at a very early stage – often immediately after the calving.

The possibility of being together – especially for the first couple of days

after the calving - is assumed to have a positive effect on both the calf and cow. The cow licks clean the calf and thus the blood circulation of the calf and the faeces and urination are initiated – in short the cow “gets the calf started”. The calf can receive small portions of colostrum during the day, and the total milk intake may be considerable. This situation is normal to the calf and as such it is better than the different alternatives often offered. Calves which must later on enter into a nursing cow system, should from the start learn to suckle from their mother.

During the first time after the calving, the cow is still affected. It starts to produce milk and its udder is tense. The physical activities of the cow change after the calving and when the cow starts to produce milk. The cow's activities are characterised by shorter lying time, more lying periods, standing rumination, increased grooming and abnormal behaviour – all in all these changes of behaviour indicate that the cow is loaded after the calving. These changes of behaviour are less common when the cow is in a calving pen or a deep litter housing system together with the calf than if the cow is tethered in a pen without the calf.

1.7 Undesirable behaviour

Undesirable behaviour may both be normal behaviour occurring with an abnormal frequency, and totally new ways of behaviour, which do not occur under natural conditions. Stereotypies are abnormal behaviour patterns, which are repeated in the same way over and over without any apparent purpose or benefit.

The frequency and amount of undesirable behaviour reflect the ability of the animal to adapt to its surroundings. Thus a high frequency is a clear indication of the fact that the surroundings are not quite right – it is difficult for the animal to adapt to the conditions. The most common, abnormal behaviour patterns among cattle are the following:

Sucking at other calves or equipment. This behaviour is most common among calves and it consists in sucking the lower jaw, ear, scrotum, penis or fold of another calf or even a piece of equipment. The behaviour is due to an un-

Chapter 1

satisfied suckling need and it occurs both in individual and joint pens while the calves are fed milk from a bucket.

Equipment gnawing (trough-biting).

The animal both bites and gnaws the equipment for considerable periods at a time. Often the behaviour is stereotypic and it both occurs among young stock and cows due to a lack of feed or fibre-rich supplementary feeds. However, the behaviour can also be caused by a lack of stimuli.

Excessive licking. The animal licks other animals or objects for very long periods at a time. Excessive licking is frequent among calves and young stock that lack social contact, occupation possibilities and roughage feed.

Pseudo rumination. The animal carries out grinding movements with its mouth as if it is ruminating, however, it does not have any feed in its mouth. This behaviour is mostly stereotypic and it occurs when cattle are fed fibre-poor supplementary feeds.

Urine drinking. Urine is “drunk” directly from the penis. This behaviour is most common among young bulls in joint pens, which are fed very fibre-poor supplementary feeds. Calves may develop this behaviour as a suckling substitute.

Tongue rolling. The animal carries out grinding movements with the tongue either in or outside the mouth (the mouth is always open). Tongue rolling,

which often has a stereotypic character, occurs among both calves, young stock and cows when they need roughage feed or when they are fed fibre-poor supplementary feeds.

Leaning. The animal presses its forehead or the bridge of its nose against another animal or a piece of equipment for long periods of time. Leaning takes place both among young stock and cows and it, probably, reflects frustration or pain.

“Dog-sitting”. The animal sits with stretched forelegs. This behaviour often occurs when the animal is going to lie down, and it is almost always due to a lack of space. Thus the animal cannot get up and lie down normally.

Horse-like rising. First the animal gets up on stretched forelegs and then it lifts the hindquarter of its body. This behaviour is caused by a lack of space in front of the animal.

Milk theft. Cows suckle milk from other cows. Milk theft is more frequent among the Jersey breed than among other breeds and it is often a local herd problem. The reason for this behaviour is unknown.

Skidding. Either the forelegs or hind legs of the animal skid. Skidding might cause that the animal stumbles and falls and thus the risk of physical injuries increases. Skidding happens on hard and slippery ground during different behavioural activities.

1.8 Literature

1.8.1 Sources

Albright, J.L., and Arave, C. W., 1997. The Behaviour of Cattle. University Press, Cambridge, 305 pp.

Fraser, A.F., 1985. Ethology og farm animals. I serien „World animal science, A5“. Editors in chief A. Neimann-Sørensen and D.E. Tribe, Elsevier, Amsterdam, 500 pp.

Fraser, A.F., and Broom, D.M., 1990. Farm Animal Behaviour and Welfare. Third ed., Baillière Tindall, London, 437 pp.

Hafez, E.S.E. and M.F. Bouissou, 1975. The behaviour of cattle. In „The behaviour of domestic animals“ edited by E.S.E. Hafez, Baillière Tindall, London, 246-294.

Munksgaard, L., og C.C. Krohn, 1990. Adfærd hos kalve og ungdyr. 667. Beretning fra Statens Husdyrbrugsforsøg, 42 pp.

Phillips, C.J.C., 1993. Cattle Behaviour. Farming Press Books, UK, 212 pp.

Sambraus, H.H., 1978. V. Rind. In „Nutztieretologi“ edited by Poul Perey, Berlin, Hambrug, 49-127.

Schnitzer, U., 1971. Abliegen, Liegestellungen und Aufstehen beim Rind im Hinblick auf die Entwicklungen von Stalleinrichtungen für Milchvieh. KTBL-schrift,10, 1-43.

Süss, M. and U. Andreae, 1984. 2. Rind. In „Verhalten landwirtschaftlicher Neutztiere“ edited by Bogner, H. og Granvogel, Eugen Ulmer, Stuttgart. 149-246.

Sørensen, J.T. og Krohn, C.C., 1999. Opstaldningens indflydelse på opdrættets adfærd, sundhed og produktion. DJF rapport nr. 9, 63 pp.

Weight, body dimensions and movement behaviour

Farm buildings and equipment for cattle must be designed according to the size of the animal. This chapter states a number of measurements and weight measures for cattle. It should be noted that the measurement and weight of cattle may vary considerably within the same age group.

Cattle are from birth to the age of six months called calves. Male cattle are from the age of six months until they are slaughtered or used for breeding purposes called bulls. Female cattle are called heifers from the age of six months until calving. Female cattle, which have calved are called cows. Young stock is a joint term for male and female cattle from the age of six months to slaughter or calving respectively.

2.1 Cattle weight and dimensions

The body dimensions of cattle are shown in figure 2.1. The height at withers of cattle is measured as the vertical distance from the lowest part of the hoof to the

top of the shoulder blades. The loin height is measured from the lowest part of the hoof to the junction of the loin and os sacrum right between the hips. The heart girth is the circumference behind the shoulder blades where the heart girth is smallest in circumference.

The total length of cows is measured from the poll to the pin bone. The body length of the cow is the distance between shoulder blade and pin bone/tail head. The width across the shoulders and hips is measured as the distance between the shoulders and hips respectively.

2.2 Young stock weight and dimensions

The body dimensions of calves and young stock at a given time of their period of growth are more dependent on the weight than the breed. Thus these housing design recommendations are calculated in relation to the weight of the animal. The weight, age and body dimension of the animal is shown in tables 2.1 and 2.2. However, the tables only apply to dairy breeds. Please see chapter 10, if you wish to know the corresponding weight, age and body dimension relations of beef breeds.

2.3 Body dimensions of cows

The fatness and lactation stage of full-grown cows will have more influence on the body weight than the body dimensions. Through the lactation the weight of the cow may vary 100 – 150 kg. The body weight and dimensions of dairy cows is shown in table 2.3 and 2.4.

2.4 Cattle movement pattern

The natural getting up movements of cattle are shown successively in figure 2.2. At the same time the figure shows the horizontal movement of the cow when it gets up. In total the full-grown cow makes use of 3.0 metres to get up or lie down. The moving-forward motion is 0.6 metre, and the minimum distance to the bedding from the head/neck of the cow is approx. 0.2 metre.

The reach of the cow during the feed intake depends somewhat on the height of the feed alley, the type of tether and

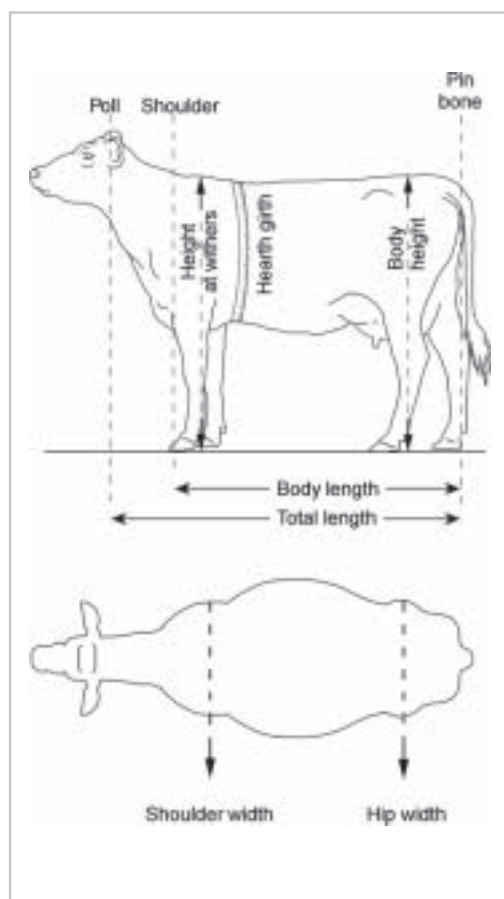

Figure 2.1.
Body dimensions
of cattle.

Table 2.1. Age and body weight of dairy breed young stock.

| Days | Months | Body weight, kg | | | |
|-------|--------|-----------------|-------|---------|-------|
| | | Large breed | | Jersey | |
| | | Heifers | Bulls | Heifers | Bulls |
| Birth | | | | | |
| 10 | 0.3 | 50 | 50 | 30 | 30 |
| 30 | 1 | 60 | 60 | 40 | 40 |
| 50 | 1.6 | 80 | 80 | 50 | 50 |
| 90 | 3 | 100 | 110 | 60 | 70 |
| 130 | 4.3 | 130 | 160 | 80 | 100 |
| 160 | 5.3 | 150 | 200 | 90 | 130 |
| 180 | 6 | 160 | 230 | 100 | 160 |
| 230 | 7.6 | 190 | 300 | 110 | 220 |
| 240 | 8 | 200 | 320 | 120 | 230 |
| 270 | 9 | 210 | 360 | 130 | 260 |
| 300 | 10 | 230 | 400 | 150 | 300 |
| 330 | 11 | 250 | 440 | 160 | 330 |
| 370 | 12.1 | 270 | 480 | 170 | 350 |
| 400 | 13.1 | 290 | 520 | 190 | |
| 420 | 14 | 300 | | 200 | |
| 470 | 15.4 | 330 | | 220 | |
| 510 | 17 | 360 | | 240 | |
| 540 | 18 | 380 | | 250 | |
| 610 | 20 | 420 | | 290 | |
| 700 | 22 | 480 | | 350 | |
| 720 | 24 | 500 | | 370 | |

Table 2.2. Weight in kg and body dimensions in metre among dairy breed young stock (large breed). The body dimensions may vary +/- 5% dependent on the breed and degree of fatness.

| Body weight, kg | Total length | Body length | Height at withers | Shoulder width | Hip width |
|-----------------|--------------|-------------|-------------------|----------------|-----------|
| 50 | 1.00 | 0.70 | 0.75 | 0.18 | 0.20 |
| 100 | 1.20 | 0.80 | 0.90 | 0.22 | 0.27 |
| 200 | 1.50 | 1.10 | 1.10 | 0.28 | 0.35 |
| 300 | 1.75 | 1.20 | 1.22 | 0.34 | 0.42 |
| 400 | 2.00 | 1.27 | 1.30 | 0.40 | 0.47 |
| 500 | 2.20 | 1.40 | 1.35 | 0.46 | 0.52 |

Table 2.3. Weight in kg and body dimensions in metre among dairy cows (large breed).

| Body weight, kg | Height at withers | Body length (shoulder/pin bone) | Total length | Hip width (thurl width) |
|-----------------|-------------------|---------------------------------|--------------|-------------------------|
| 500 | 1.35 | 1.40 | 2.20 | 0.52 |
| 550 | 1.37 | 1.49 | 2.29 | 0.53 |
| 600 | 1.39 | 1.57 | 2.35 | 0.54 |
| 650 | 1.41 | 1.64 | 2.41 | 0.55 |
| 700 | 1.42 | 1.70 | 2.45 | 0.56 |

Table 2.4. Weight in kg and body dimensions in metre among dairy cows (Jersey).

| Body weight, kg | Height at withers | Body length (shoulder/pin bone) | Total length | Hip width (thurl width) |
|-----------------|-------------------|---------------------------------|--------------|-------------------------|
| 300 | 1.19 | 1.20 | 1.94 | 0.44 |
| 400 | 1.24 | 1.27 | 2.02 | 0.47 |
| 500 | 1.25 | 1.32 | 2.04 | 0.50 |

Chapter 2

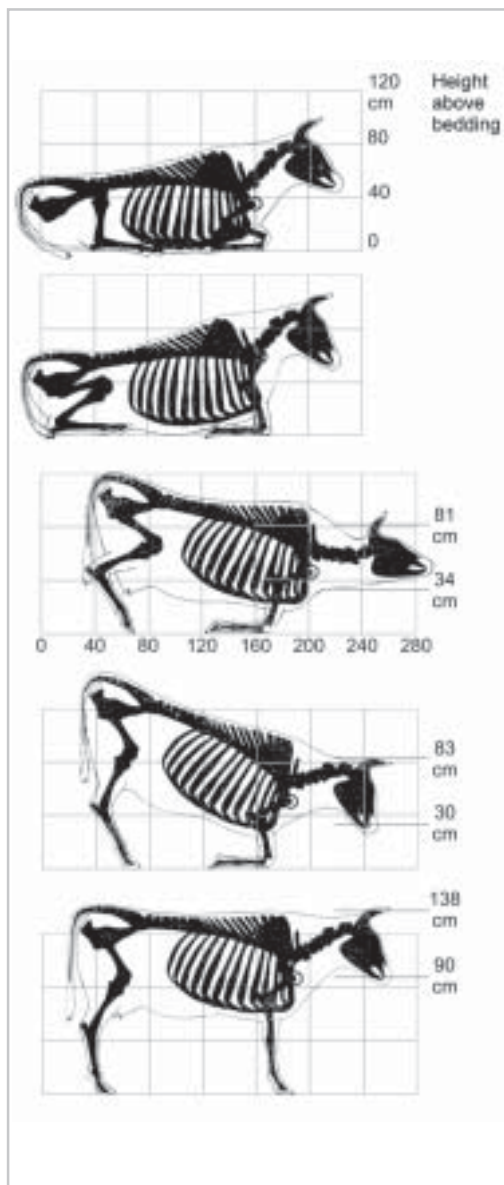

Figure 2.2.
Natural getting up
behaviour of cattle
(Anonym, 1969).

the feeding rack. However, it rarely exceeds 0.6 – 0.7 metre, see figure 2.3. For further information about the lying down and getting up behaviour, please see chapter 1, section 1.3.2.

From the shoulder region to the tail head (the body length) the spine is not very supple, which makes it difficult for the cow to make sharp changes of direction while it is walking. Therefore much space is required in the direction of motion for the cow to turn 90° and 180° respectively (see figure 2.4a and 2.4b). When making a 90° turn it is thus easiest for the cow to make two 45° turns (see figure 2.4c).

The separation of cows is ideal at a 45° change of the motion direction (see figure 2.5)

2.5 Freedom of movement and exercise

A normal development of the motor apparatus of cattle (skeleton, tendons and muscles) and the coordination of motions require both freedom of movement and frequent exercise.

Several investigations have shown that exercise among cows in tied-up housing systems (grazing versus zero grazing) has a positive influence on reproduction, hoof and limb health and on several metabolic disorders. Grazing is a natural form of exercise.

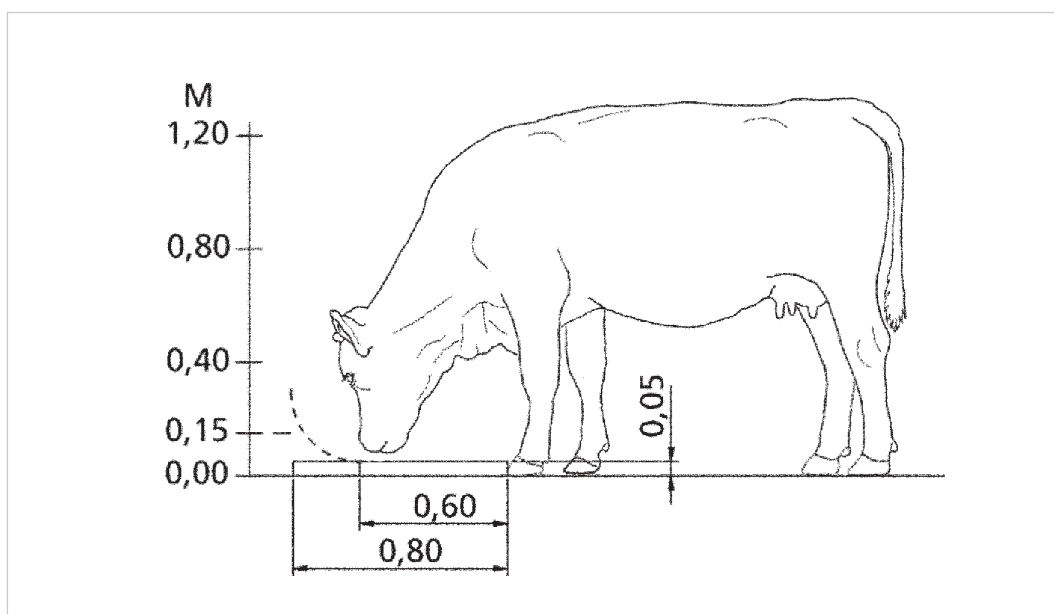

Figure 2.3.
The reach of cows
during feed intake.
The reach depends
on the type of tether
and the feed alley
height. (Model from
Mortensen, 1971).

Background and motivation

- It is easier for cows that exercise to get up and lie down than cows that do not exercise at all (Gustafson et al. 1988, Krohn and Rasmussen 1990)
- At pasture dairy cows walk approx. two to four kilometres daily, depending on the amount of grass and the size of the fold (Zeeb 1983, Krohn et al. 1992).
- In loose housing systems with access to an open exercise yard cows walk about one kilometre per day (Zeeb 1983).
- The reproduction conditions are improved and the level of diseases is reduced when cows kept in tied-up housing systems exercise regularly, e.g. graze during the summer (Krohn 1986, review article).

2.6 Literature

2.6.1 Sources

Anonym 1969. Alt det nyeste inden for landbrug, havebrug og husholdning. Det Kgl. Danske Landhusholdningsselskab.

Gustafson, G. M., Andersson, M. & Lund, E. 1988. Getting up and lying down behaviour in tied and exercised dairy cows. SVE-summer meeting. Skara, Sverige.

Krohn, C.C. 1986. Motion til malkekøer i bindestalde. Ugeskrift for jordbrug, 46, 1364-66.

Krohn, C.C. & Rasmussen M.D. 1990. Motion til malkekøer. Medd. nr. 763 fra Statens Husdyrbrugsforsøg, 4 pp.

Krohn, C.C., Munksgaard, L. and Jonassen, B. 1992. Behaviour of dairy cows kept ind extensive (loose housing/pasture) or intensive (tie stall) environments. I. Experimental procedure, facilities, time budgetsdiurnal and seasonal conditions. Appl.Anim. Behav. Sci., 34:37-47.

Mortensen, B. 1971. Forsøg med bindsler til køer. 1. 33. SBI-landbrugsbyggeri. Statens Byggeforskningsinstitut. 156 pp.

Zeeb, K. 1983. Locomotion and space structure in 6 cattle units. Farm Animal Housing and Welfare, Martinus Nijhoff Publishers for CEC, 129.

2.6.2 Supplementary literature

Hoffman, H. & Rist, M. 1975. Tiergerecht und arbeitswirtschaftlich günstige Anbringevorrichtungen für Kühe. Schweiz. Landw.M.h. 53:119-126.

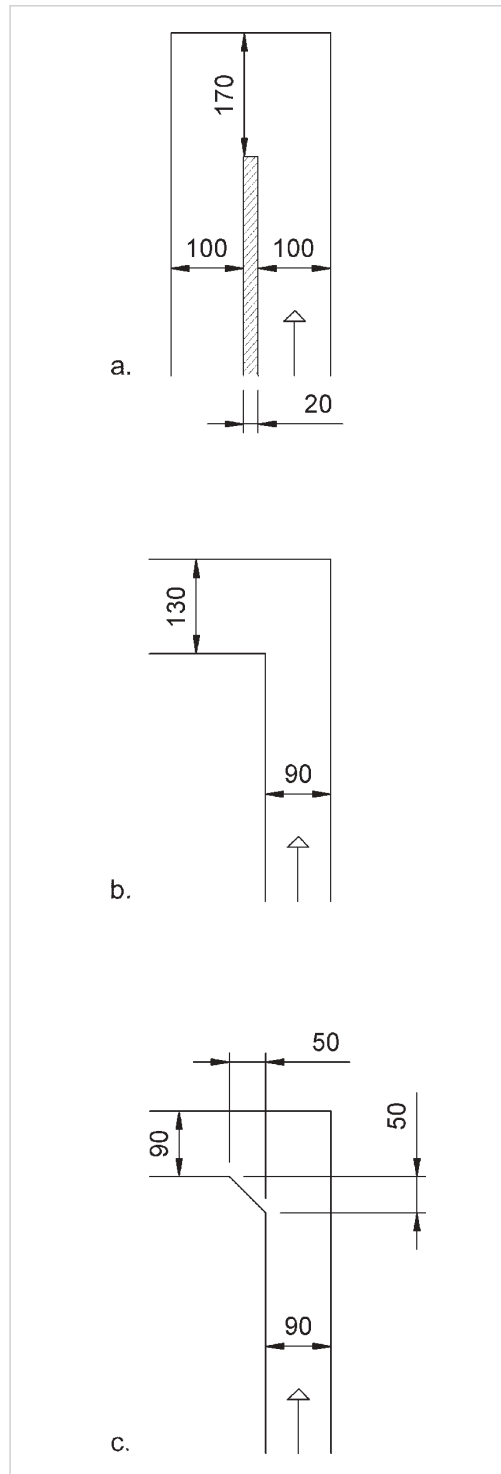

Figure 2.4. Space in connection with 90° and 180° turns in the direction of motion, cm.

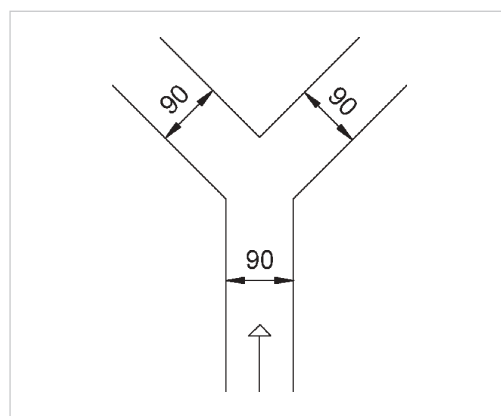

Figure 2.5. Separation in two directions, 45° of the direction of motion.

Health

3.1 General health state

Danish cattle farms are free from the infectious diseases that cause trouble to dairy farmers in other parts of the world, who suffer direct losses in the shape of sick and dead animals as well as increased expenses for handling and treatment of sick animals. At the end of 2000 Denmark was among other things free from cattle tuberculosis, brucellosis, leucosis, foot-and-mouth and IBR diseases.

Today the greatest health challenge within cattle farming is the so-called production-related diseases. The characteristic feature of these diseases is that the transition from health to disease is more flu-

ent and determined by far more factors than the balance between the infectious disease and the individual animal of the herd. The main cause of production-related diseases may both be housing design, feeding and management (see table 3.1). In the recommendations of this report, we have taken the physical factors of farm housing design into account, which can reduce the frequency of injuries and reduce the risk of diseases among cattle.

In the following chapter it will be described in which ways the building design as well as the traffic of persons can result in the introduction and spread of infectious diseases. Figure 3.1 shows the numerous environmental factors, which influence cattle.

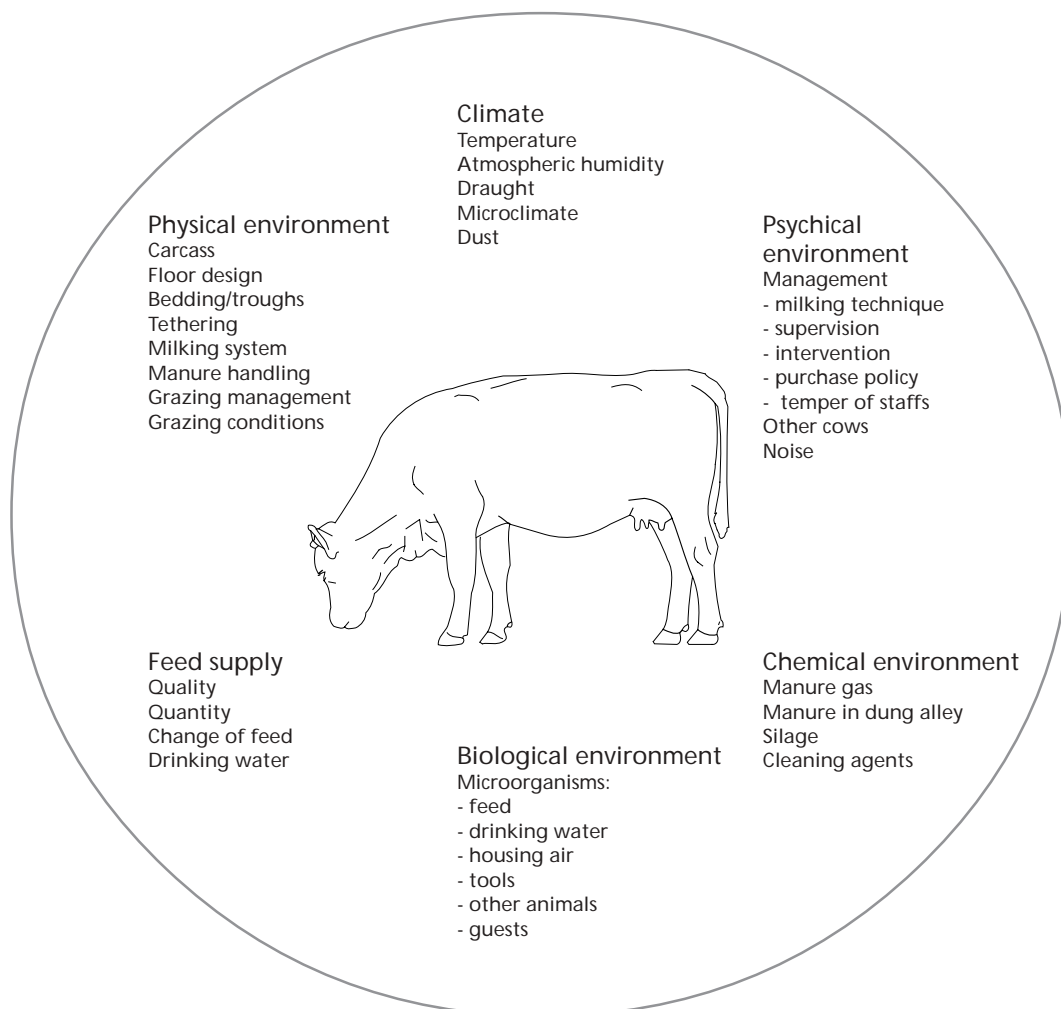

Figure 3.1. Many environmental factors influence cattle. Diseases arise when cattle, as a consequence of influences from the surroundings, – also the feeding – are thrown of their natural physiological balance. This figure shows some of the environmental factors, which influence the health of cattle.

3.2 External infection protection

The external or outer protection against infection is characterised by the measures, which are carried out on each individual farm to avoid or limit the introduction of infectious diseases. The infectious diseases may either be undesirable for the country as a whole or for the individual farm, if the farmer has chosen that his herd should be at a higher health level.

When practicing the external protection against infection one must keep in mind the cattle farmer's general attitude that Danish cattle farms are open farms, which must be convenient to visit.

3.2.1 Purchase of cattle

The risk of introducing new infectious diseases is by far greatest when purchasing new cattle. A well-established farm with a sufficient rearing is able to limit or avoid purchase. However, in connection with an extension of the farm, it might be necessary for a period of time to purchase cattle. In this case it is important to plan as well the number of cattle and the time of arrival to the farm well ahead. By planning, thoroughly, a good general view will be formed, which should result in a purchase of cattle from as few farms as possible. Moreover, it should also provide time to achieve the necessary knowledge of the state of health (BVD disease, Salmonella Dublin, para-tuberculosis and infectious udder germs) of the farm from which the cattle is to be purchased. It is the buyer that must take action to protect his herd against infection and thus he should make the specific demands. It is fair that a documentation of the state of health of the herd of the supplying farm within the last three to four years is included when cattle is purchased.

The purchased cattle should be placed in the farm housing as early as possible, so that they can get used to the infectious diseases of the new farm and have the time to produce high-quality colostrums. Cattle purchased from abroad may require particular attention.

3.2.2 Handing over cattle

When living as well as dead cattle are leaving the farm there is a risk that diseases may be passed on to the existing cattle.

There is a danger that diseases may be passed on to cattle when they are sent for slaughter, cattle shows or joint grazing and if the carrier or cattle from another farm touches them. Cattle for slaughter must always be viewed as animals of a low level of health, as they may be healthy disease spreaders. Thus it is important that cattle for slaughter are separated from the rest of the herd until they are picked up.

Even on a well-run farm, dead cattle cannot be avoided completely. Thus a place for the contemporary deposit of dead cattle must be established. The deposit place for dead cattle must be cemented and fenced in to avoid foxes, dogs and cats. Dead cattle must either be deposited in an enclosed container or they may be covered with a tarpaulin or the like. The deposit place should be situated in such a way that the lorry from the incinerating plant does not cross the carriage road between the feed silo and feed alley. Furthermore, the deposit place should be highly demarcated from the rest of the farm.

Table 3.1. Some diseases can easily be attributed to the direct influences from the immediate environment of the cow. This table shows the connection between possible causes and the resulting injury or disease.

| Cause | Disease |
|----------------|---|
| Building | Scratches and wounds Skidding Pneumonia Heatstroke/frost-bites |
| Housing system | Knee and hock pressure injuries Tail damage Acid injuries on deep litter Feed and leg diseases Mastitis |
| Feed alley | Neck injuries Swollen carpus Feet and leg diseases |
| Tether | Pressure injuries Teat damage Skidding |

Chapter 3

The driver from the incinerating plant must under no circumstances touch the live animals of the farm.

3.2.3 Admittance of persons

Visits to farms also involve the risk that diseases may be passed on to cattle, however, this risk is not as considerable as the purchase of or touching of cattle. It is practical to allow visitors one entrance and exit place only. This place should provide cleaning facilities outside the farm building.

Service staffs (inseminators, veterinary surgeons, milk recorders, and hoof trimmers) are in direct contact with cattle, also on other farms, and thus the risk of passing on diseases to cattle cannot be eliminated. Thus it is important that the visit of the service staffs only takes place through a given access road where it is possible before and after the visit to thoroughly clean and disinfect the equipment they have brought with them and their footwear.

The necessary facilities must be placed in a way that it seems naturally for visitors to pass them. Service staffs that touch the cattle must change working coat or overalls between each visit. If the individual farmer wishes to take further steps in the form of washing and change of clothing and footwear, the necessary facilities must be made available (cupboard for working coat and boots). (See figure 3.2).

Other guests or visitors from agricultural colleges, schools, nursery classes, etc. do not pose the same risk, as they only in very few cases have direct contact with the cattle of the farm and as they have rarely had recent contact with other cattle. If the farmer receives visitors from abroad, or if he wishes to take further safety precautions in connection with visits, the guests may be provided with overalls and overboots. Moreover, they must be able to wash hands and boots after the visit on the farm.

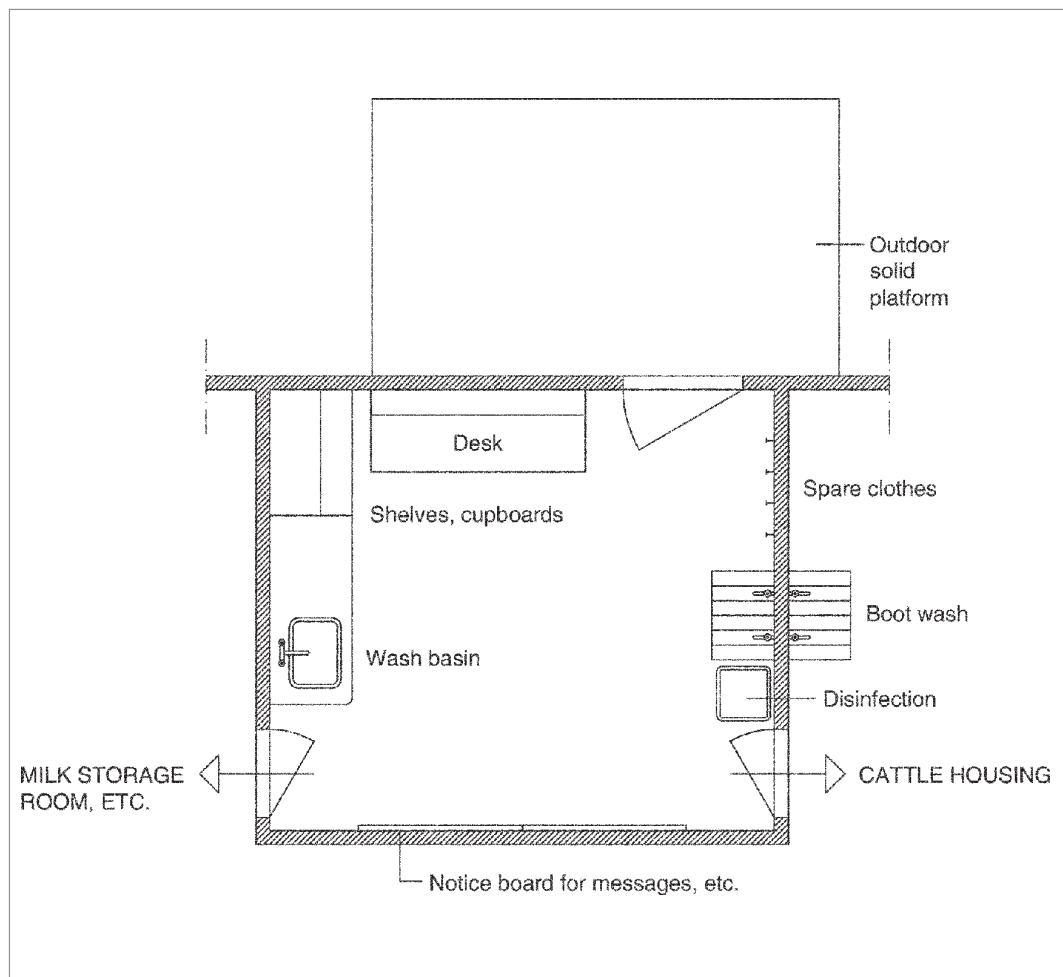

Figure 3.2.
Entrance room.

3.3 Internal infection protection

Internal protection against infection consists of those measures a farm carries out in order to avoid or limit the spread of infection between different groups of cattle, e.g. age groups or farm sections. The internal protection against diseases is especially actual in connection with outbreak of infectious diseases or reconstruction programmes. However, the internal protection against diseases should also be considered during the daily work, e.g. boots should be washed when passing from one farm section to another. Furthermore, the internal protection against infection also consists in avoiding the spread of manure in feed and troughs.

3.3.1 Moving around cattle within farm

Cattle must continuously be moved from one section to another when the herd reaches a certain size. Calves are moved to group pens, heifers that are about to calve must be placed among the milking cows, cows must be dried off and moved, etc. Thus it is practical to design the housing system in such a way that the moving around of cattle requires as few staffs as possible and the design must allow particularly vulnerable cattle to be separated from the rest of the herd in case of infectious diseases. Moreover, it is practical to rear sucking calves and small calves in sections and group systems. For further information, please see chapter 4: "Working routines and supervision".

3.3.2 Placing and moving around cattle and young stock

Newborn calves must be placed in clean single pens. Continuous placing of calves in random pens in the calf house increases the disease risk. Thus it is best to fill one row or block of single pens at a time. Moreover, feeding is more rational and it is easier to inspect calves frequently during risk periods, if calves are placed next to each other according to age.

The moving of calves from single to joint pens can with great advantage be carried out in groups. In this way it is avoided that younger calves that are less resistant to diseases are placed among older calves with a higher infection rate. Moreover, young calves are accustomed to herd behaviour without dominating old calves at the water and feed trough.

3.3.3 Sick cattle and cattle under treatment

Normally, there are no health reasons for separating full-grown cattle in groups. However, in connection with different reconstruction programmes and during fights against different kinds of mastitis, it might be efficient to separate cattle in different groups.

The government order concerning production and transport of milk does among other things demand that cattle with diseases, which can be transmitted to human beings through the milk, must be separated from the rest of the herd. Moreover, cattle that show visible signs of general health disorders or that suffer from reproduction diseases with discharge, intestinal disease with diarrhoea and fever as well as mastitis, must be separated from the rest of the cattle.

It is important that the place for these sick animals is arranged in a way that they have the same feeding and housing opportunities as the rest of the cattle. The entrance conditions must be good, so that sick cattle can be moved and handled with a minimum workload. It is not allowed to use the calving pen as convalescence area for cows with open wounds, abscesses or other sufferings that cause discharge of pus. Sick cattle and cattle that require treatment for other reasons must be housed centrally and close to the necessary cleaning and disinfection facilities.

3.4 Separation and treatment section

A separation section is an area of the housing in which individual cows can easily be separated from the rest of the herd. The separation can either take place manually by means of gates or automatically by means of electronic marking.

A treatment section is an area of the farm building, which is used routinely for both inseminations, pregnancy checks and occasionally for examination and treatment when diseases occur.

The separation as well as the treatment section must have the same facilities and equipment as the rest of the building. It is, especially, important that cattle kept temporarily in a separation or treatment section have access

Chapter 3

to water and usual feed in a trough, a dry resting place with a deformable bedding.

The treatment pen should facilitate catching and fixing of cattle that must be examined or treated. A closed pen must be equipped with a manhole door or some other fast escape route. The pen must be lit up properly and access to warm and cold water is required, so that equipment, etc. can be cleaned or washed after treatment. Moreover, there should be a plug near the pen.

Treatment pens must be minimum three metres long and broad (see figure 3.3).

3.4.1 Space for hoof trimming

It is practical to establish space and facilities for hoof trimming. Moreover, good washing and cleaning facilities are required, preferably on a cemented foundation, so that the hoof trimming box and tools can be cleaned efficiently.

3.4.2 Medicine and chemical storage

There must not be kept any chemicals, medicine or other pesticides near cattle. Such preparations must be stored in a locked cupboard or the like with no admittance except on business. Tools, medicine and other equipments as well as chemicals must be stored under well-organised conditions on shelves, e.g. in closed cup-



Figure 3.3.
Design of
treatment pen.

boards. The storage facilities must invite order. The storage should be arranged in such a manner that confusion and mistakes do not occur in case of new staffs or relief men.

3.4.3 Waste handling

Waste containers for used disposable equipment must be provided at all places where the service personnel carries out cleaning and disinfection. After use, disposable syringes and hypodermic needles must be kept in suitable containers until they are removed for destruction. All packaging and medicine residues must be disposed by a veterinary surgeon or the chemist's.

3.5 Cleaning and disinfection

Cleaning is important prior to disinfection. The disinfectants do not have maximum effect without preceding manual cleaning. Disinfection routines are, especially, carried out on farms in case of:

- Outbreak of infectious diseases to limit the spread of the infection
- Establishment of infection barriers between groups of cattle or individual sections
- Surgical intervention and treatment of cattle
- Limitation of germ contamination of animal products.

3.5.1 General cleaning information

An appropriate cleaning and subsequent disinfection procedure of empty farm buildings and pens or stalls could be:

- Thorough cleaning of the areas
- Soaking
- Cleaning by means of high pressure cleaner
- Subsequent disinfection with a suitable disinfectant, if necessary
- Thorough airing and drying of alleys and stalls.

3.5.2 Specific information about disinfection, including instructions

The choice of disinfectant depends on several conditions, i.e. disinfection method, time of effect, temperature dependence, pH dependence, spectrum of effect, etc. At the same time eventual incompatibility with other substances must be considered if the effect seems to be too little. In table 3.2 the number of disinfectants are listed which cannot be mixed due to toxic effect or because they neutralize each

other mutually. The final choice as to disinfectant can be difficult, however, primary characteristics of disinfectants, which can be used in connection with livestock husbandry are listed in table 3.3. When disinfecting farms with cattle inside iodofors and oxidizing disinfectants such as Clorid-cid, Jettadam A-100 and Virkon-S can be applied. These disinfectants can also be used for sprinkling.

3.6 Literature

Anonym, 1998. Gårdbutikker og besøgslandbrug. Råd, vink og praktiske anvisninger om start og strategi. Landbrugets Rådgivningscenter 62 pp.

Table 3.2. Disinfectants, which cannot be mixed due to toxic effect or because they neutralize each other.

| Group | Cannot be mixed with |
|-------------------------------|--|
| Acid | Bases, chlorine preparation and chlorhexidine |
| Base | Acids, iodofors and chlorhexidine |
| Quarterner ammonium compounds | Soap, strong acids and bases as well as iodofors |
| Chloramin, hypochlorit | Acids |
| Jodoforer | Bases, slaked lime and quart, ammonium compounds |
| Chlorhexidin | Acids and bases |

Table 3.3. Outline of the qualities of each disinfectant.

| Disinfectant | Wash effect | Effective against | | | Fast effect | Sensitive to organic matter | Recommended | | Corrosive | Envir. impact |
|------------------|-------------|-------------------|--------|-------|-------------|-----------------------------|-------------|-------------|-----------|---------------|
| | | Bacteria | Spores | Virus | | | PH value | Temperature | | |
| Acids | no | +(+) | - | + | ++ | ++ | < 2 | > 5° C | +++ | no |
| Strong bases | yes | ++ | (+) | +++ | + | - | - | - | ++ | no |
| Hypochlorite | no | +++ | - | +++ | +++ | +++ | > 7 | < 35° C | +++ | no |
| Chloramines | no | +++ | - | +++ | ++ | ++ | ca. 7 | - | +++ | no |
| Iodofors | yes | +++ | + | + | +++ | ++ | < 6 | < 35° C | + | ? |
| Phenol | yes | ++(+) | - | (+) | ++ | ++ | > 8 | < 40° C | - | yes |
| Quart. amm.comp. | yes | +(+) | - | - | +++ | +++ | ca. 8 | - | + | ? |
| Glutaraldehyde | no | +++ | +++ | +++ | + | - | > 7 | > 5° C | - | no |
| Peracetic acid | no | +++ | +++ | +++ | ++ | + | < 6 | > 5° C | ++ | no |
| Oxidising | no | +++ | ++ | +++ | ++ | + | < 6 | > 5° C | + | no |

- = none
+ = few
++ = average
+++ = many

Work routines and supervision

4.1 Work routines, supervision and welfare

The planning of a production plan is based on the cycle of cattle from birth to departure from the farm.

Work routines and supervision influence the welfare and yield of cattle considerably. Thus these two factors are preconditions of an optimum utilisation of the herd potential. A practical design of the farm building and equipment as well as easy and unobstructed access to each animal will ensure that the observation and the daily working routines can be carried out without an unnecessarily high work performance.

Special attention must be drawn to the following issues:

- Distribution of feed and ensuring that the feed is within the cattle's reach
- Supervision and inspection of feed alley, feed silo, automatic feeder, watering cup and water troughs
- Cleaning of resting areas and alleys
- Supervision and registration of the health condition and yield of each single animal
- Supervision at calving
- Routine tasks, e.g. insemination, pregnancy test, udder health control and udder care, hoof care, blood sampling, dehorning, ear tagging, removal, fatness estimate and weighing, etc.
- Handling and treatment of sick cattle
- Going through alarm lists of automatic feeding and milking systems, activity monitoring systems, water meters, etc.

In order to control the distribution of feed to each animal, to carry out observation for oestrus efficiently, etc. it is an advantage that cattle can be subdivided in a number of functional groups. This subdivision will make it easier to follow up on the groups and each animal. The maximum group size can be determined either as the number of cows that can be milked per hour, or it may be assumed that a maximum of 70

cows are able to recognise the ranking of each other in a herd (Syme and Syme, 1979).

4.2 Cleaning and grooming

The cleaning of resting area and the alleys of the cattle housing is a precondition for milking clean cows. It is much more time consuming to clean udder and teats when milking the cows than it is to clean the resting area. Cleaning of the resting area is especially important if an automatic milking system (AMS) is applied, as it is not possible to clean the dirty cows manually before they are milked in this system.

The resting area must be inspected, supervised and cleaned several times per every 24 hours. In practice it is best to clean and litter the resting area while the cows are being milked or when they are prevented from entering the resting area, e.g. when they are locked in self-locking feed barriers or kept in the feeding area. The effect of a clean bed is greatest when cows after milking or joint feeding are able to lie down in a clean and well-littered resting area. Typically, grooming in loose housing systems is left to the cows themselves. Fixed or rotating brushes can profitably be mounted in the housing system. However, they must be placed in a way where they do not disturb the cow traffic.

4.3 Hoof care

Hoof care must be carried out as occasion requires. The farm building design must facilitate routine checking of the hoofs of cattle and hoof trimming two to four times per year. The activity connected to hoof trimming is probably not a positive experience for cattle. It should be possible to work with groups of untethered cattle. When designing cattle housing, space must be left for a hoof-trimming box and the cows must be able to walk to and from the box. Moreover, hoof trimming should not be carried out in those places where cattle should be able to walk safely during the day, e.g. the holding and milking area.

Dry and clean alleys and good deep-litter areas contribute to a low level of hoof moisture and thus keep the hoofs hardy, healthy, dry and strong.

In case of preventive and emergency treatments it should be easy to establish an effective hoof bath. The best solution would be permanent hoof baths. Hoof baths shall be easy to clean and it is best to place them at a place cattle pass when they return from the milking area. It should not be possible for fluid from the hoof bath to splash on the other cows.

4.4 Supervision of housing climate

The climate inside the cattle housing must be dry, free from draught and well-ventilated (for further information, please see chapter 5). In order to monitor the climate, automatic monitoring systems can be built in, which will regulate the ventilation in naturally and mechanically ventilated cattle housing.

Monitoring systems can be combined with an alarm that puts on an acoustic or optical alarm if the ideal climate is interrupted. If a mechanical ventilation system is installed, an emergency ventilation and alarm system must be installed, too.

4.5 Herd supervision

All animals must be inspected at least once per day. Supervision and registration of the state of health of each individual animal are crucial for the welfare and security of cattle. Thus an ideal supervision is achieved if the farmer can easily make several observations during his daily tasks in the cattle housing.

Calving and treatment sections as well as the group of first calvers must be placed in a central place, which the staffs pass several times during the day.

Monitoring must be integrated as a natural part into the list of daily routines.

Manholes or small one-hand operated gates can secure an easy access to different areas and pens of the cattle housing as well as a quick escape route for the staff.

An observation platform will enable the staffs to orientate themselves quickly of the situation in the cattle house. In emergency situations a video monitoring system which provides a permanent record of the total or just some highly actual parts of the housing, e.g. the calving section, enables the staff to intervene faster than if the emergency was not detected until the next routine check.

4.6 Herd handling

In connection with the tending and monitoring of cattle, there is a need to be able to fix individual animals and to move one or more animals at a time. It is e.g. natural to separate individual cows from the group in connection with the milking. A suitable alternative could be to use the self-locking feed barriers of the feed alley. This self-locking feed barrier provides an efficient, easy and cheap solution as regards the handling of individual cows.

The requirement for separation pens in which animals are kept for a short period of time is that it must be possible to fix individual animals. Moreover, cattle must have access to water and feed and it should be possible for them to rest. Staffs and external persons must by means of manholes or small one-hand operated gates have easy access to those pens in which the separated cattle are kept. The gates will facilitate individual animal's placing in and removal from pens.

Among young stock there is a need to be able to fix animals that must be treated. A self-locking feed barrier can e.g. be applied in partitions with heifers that are going to be inseminated.

The housing design must facilitate the moving of cattle, which is a result of the natural cycle. It must be possible to move animals in groups and to drive them quietly and peacefully from one partition to another. Thus it is practical to establish good drive alleys and gates, which can lead cattle in the right direction. The gates must be easy to operate by one person only.

It should be possible to accustom cattle to new facilities, e.g. heifers that should later be placed among the other cows. Thus cows that are kept in tied-

Chapter 4

up housing systems must as heifers be accustomed to stalls and cows kept in cubicle housing systems must as heifers be accustomed to cubicles. The heifer must feel safe in its housing system when it is placed among cows after its first calving.

It is easiest to accustom first calvers to cubicles if they are as heifers placed in pens with cubicles at an early age. Heifers on deep litter require a longer learning period to get used to cubicles (see table 4.1).

It is recommended that cows are not allowed to walk directly from the milking to the resting area after milking. This recommendation is based on the fact that the sphincter of the teat channel must be able to close efficiently to prevent environmental bacteria from entering the udder. It takes between 10 minutes and two hours for the teat sphincter to close depending on the course of the milking. (MC Donald, 1975).

When there is one feeding area per cow, the distribution of restrictive feed can be practised if the feeding rack is designed in such a way that superior cows cannot chase away/disturb the subordinate ones.

One feeding area including a self-locking feed barrier per cow is an excellent way to handle cattle, e.g. when they must be fixed in groups in connection with pregnancy checks, selection of samples from each animal as well as

other treatments or the singling out cattle for subsequent treatment.

If there is more than one cow per feeding area the working routines and functions must be secured in other ways. E.g. the feed ration of subordinate cows must be ensured, the feed separation must be met, sufficient feed must be supplied within reach, restrictive feed must be distributed to individual animals and cattle for treatment must be fixed alternatively.

The precondition for an optimised feed efficiency is that each cow or group of cows can receive a feed ration, which is attuned to the need of the cow or group of cows.

The choice of feeding rack has a great influence on the amount of feed that is spilled onto the feeding area. The choice of a neck rail may in connection with certain feedstuffs result in a larger feed loss than if a self-locking feed barrier is chosen.

Self-locking feed barriers provide the opportunity of blocking off cattle from the feed. Thus the feed can be distributed before the animals have access to it.

4.7 Handling of cattle and animal – human relations

The welfare of both cattle and humans of a farm depends on a trusting handling of the large number of animals in different age groups. Thus time must be spent on adjusting cattle to positive

Table 4.1. Recommended adaption time in cow housing, number of weeks before calving.

| First calvers housed in/on | Placement in cow housing, no. of weeks before calving | | | First calvers at pasture |
|----------------------------|---|-----------|-------------------|---|
| | Deep litter and sep. feeding | Cubicles* | Tied-up housing** | |
| Deep litter | 3 | 9 | 12 | Adaption to cow housing can be modified by combining it with grazing. |
| Cubicles | 3 | 3 | 6 | |
| Tied-up housing | 6 | 6 | 3 | |
| Slatted floor pens | 3 | 6 | 9 | |
| Grazing | 3 | 6 | 6 | |

* If heifers have not been accustomed to cubicles after 2 – 4 days, they must be tethered daily.

** If heifers have been tethered earlier on, e.g. in connection with insemination, the adaption period may be halved.

close contact as early as possible. Cattle that are easy to work with during the daily work will at the same time reduce the number of staff injuries. Moreover, the adjusting of cattle to positive close contact with humans will ensure that the routine tasks, which require close contact with each animal, are carried out rationally.

The relationship between cattle and the person who tends them is an important factor. Several examinations of cattle as well as pig farms show a positive connection between a friendly management and the production results obtained. Thus Seabrook found, in an examination of 24 cattle farms, a yield difference of 15% between those herds in which the cowman “spoke with the cattle” and touched them much and the farms in which the level of contact between cattle and cowman was very small. (See table 4.2).

Under experimental conditions it has been proven that even a brief and negative treatment can cause a drop in the milk yield of up to 10% next time the cow is milked.

In connection with several species (e.g. geese, dogs and horses) it is the case that there are several periods of their lives where they respond more to contact with other animals and hence human beings (the sensitive period). Examinations prove that frequent contact has a considerable influence on how trustful the animal will become. Especially, if the contact takes place during those periods of time where animals are already loaded in one or the other way, e.g. after weaning, during calving, when first calvers are accustomed to milking and when the animal is being moved to new surroundings (Fraser & Broom, 1990).

The daily contact with cattle must be kind, consequent and predictable. The staff should frequently talk to cattle and touch them. Any approach must be made on the terms of the animals, i.e. the animal must be able to see and sniff at the person before it is being touched (see chapter one: Behaviour of cattle). Generally, the handling of cattle is easiest in familiar surroundings.

The cowman must be very much aware of the behaviour of the animal and he must know each animal of the herd very well. All cattle must be inspected at least once per day. (Anonym, 1991 and Anonym, 1997).

The rising number of large farms combined with increased automation involve the risk that the contact with each animal is being reduced. Naturally, this development will result in a less trusting (tame) animal and thus, at every subsequent handling, in a loading of the animal, to the detriment of the welfare and production of cattle and perhaps of the staff, too. This circumstance calls for increased attention and research in the years to come.

4.7.1 Calves, heifers and cows

During the first couple of weeks after the calve is born it responds very much to human contact. A few minutes of daily, positive contact with human beings will during this period (the primary period of socialisation) lay the groundwork for the later sociability and tractability of cattle. Examinations have shown that it is easier to obtain a close relationship of trust with calves kept in single pens than joint pens and it is, especially, difficult as long as the calf is kept together with its mother.

However, a constant and stable trust in humans is only possible, if the primary

Table 4.2. Connection between yield level and handling of the animal (Seabrook, 1994).

| | Milk yield | |
|--|------------|-----|
| | High | Low |
| Kind touch during milking, number/minutes | 2.1 | 0.5 |
| “Conversation with cows” during milking, words/minutes | 12.4 | 0.0 |
| Voluntary contact between cow and milker, number/minutes | 10.2 | 3.0 |
| Flight distance (nervousness), m | 0.5 | 2.5 |

Chapter 4

contacts are followed up by frequent positive contacts during the subsequent rearing period (Krohn, 1996). In addition to the first sensitive period after the calf is born the chance of establishing a good relationship of trust is best when the animal is in an emotionally impressionable situation (e.g. weaning, isolation, displacement, calving, etc.). The social ties that are established during these circumstances are often just as stable as those established during the primary period of socialisation.

In order for first calvers to be easy to handle and for them to have a high and stable milk yield, it is important that they are both trustful and tame, even before they calve.

Cattle can tell people apart. A number of experiments show that the colour of clothing is an important distinctive mark. Cows are able to connect positive/negative handling both with colour of clothing and a certain place (Hemsworth and Coleman, 1998).

Thus an unpleasant but necessary handling of dairy cows should not take place in the milking area and the clothing of the active person should not have the same colour as the working clothes, which the milker wears. It is especially important that heifers are handled positively the first couple of times they are milked. In this way the animal will not associate milking with a negative treatment and hence it will not fear the milker.

4.7.2 Bulls

Young bulls and breeding bulls must always be treated with respect and alertness by means of a confident and firm handling. The bull should always regard the farmer as the dominating part. Moreover, the farmer should know the normal behaviour of each bull and he should especially watch out, if the bull does not behave as it usually does. When bulls that are normally calm suddenly turn aggressive this is often due to the fact that something, which they are unaccustomed with, has happened to them. They may e.g. have been moved, have lost some females or they may experience pain due to injuries or disease. During such situations the farmer has to be particularly alert.

4.8 Taking into use renovated and new housing systems

During the planning the farmer must set aside time for placing cattle in the new or rebuild housing system. A minimum of 14 days should be set aside for taking the farm into use from the workmen and the equipment suppliers have finished their job in the building. Moreover, the defects and shortcomings should be repaired before cattle are placed in the new housing system.

It may even be a good idea to set apart an extra week for cattle to familiarise themselves with the new surroundings in small groups. This extra week will take the first day easier where the cows must e.g. be milked in the new housing system. (See table 4.3).

4.8.1 When will the new housing be taken into use?

The new or rebuilt housing may e.g. be taken into use during the period of turning out to pasture. At this point of time the herd will have build up a stable hierarchy and the physical fitness of the cattle will be optimum. If cattle are placed in the new housing later on, the hoofs will be vulnerable to intensive traffic on the new floors.

The worst situation – which should be avoided – is to move cattle in the middle of the winter. At this time of the year cattle must establish a totally new hierarchy as well as cope with the new surroundings. This may lead to a long-term unrest on the farm and many injuries may arise as well as abnormally large hoof wear.

It should always be avoided to take an unfinished housing into use, as this may influence cows' habituation to the new housing negatively. The new routines that cows learn should be lasting.

If cattle should be accustomed to a new milking system/principle, e.g. automatic milking, it is even more important that the housing is totally ready before taking it into use.

4.8.2 Making ready housing and technique

The farmer ought to have worked out a detailed plan of action for taking the new housing and techniques into use.

The schedule should consider all the tasks, e.g. preparation of the milking system, checking of drinking water systems, running in of feeding systems, feed silos and tanks as well as preparing the resting area.

It is important that there is sufficient labour available on the farm during the period when the new housing system is taken into use. It may be necessary to hire extra staffs for a period of time.

Sharp equipment edges that animal or man may bang against should be avoided. In connection with cubicles neck rails must be placed far ahead. It is advantageous to coat new floors with

asphalt coating and apply a thick layer of sawdust on the asphalt coating in order to reduce strong hoof wear during the first period of time.

It is necessary to test and adjust as well as study the operational manual for the various technical devices, including the data recording and steering equipment.

If the farmer has already considered the above-mentioned measures and chosen a date, outside the peak load period, when the new housing should be taken into use his full attention can be devoted to accustoming cattle to the new housing.

Table 4.3. Example of a plan for taking the new housing into use. The plan includes the days up to and the first milking.

| Days prior to full use | Action |
|------------------------|--|
| Min 30 | Hoof trimming of cows and first calvers. |
| 7 | The resting area is littered. Feed silo and feeding system are filled up. Milking towel, milking aprons/clothes and other materials such as teat dip and cleaning materials, brushes and tubes must be ready. |
| 5 | The cows pass through the housing. |
| 4 | The cows stay 1 – 2 hours in the housing and are supplied a tasty feedstuff in the feed alley. The cows should not be caught in the self-locking feed barriers. The milking system is checked by an adviser on milk quality. |
| 3 | The cows pass through the milking parlour on their way to the feed alley where they are supplied feed as the previous day. |
| 2 | The cows are gathered in the holding area. The milking system is started, and the cows stay in the milking stalls 1 – 2 minutes. The cows are fed at the feed alley as the previous days and they are caught in the self-locking feed barriers for a while. Cows that lie in the cow alleys are loosely tied up in the cubicles. |
| 1 | The first milking is carried out in the new housing, and a full feed ration is administered in the feed alley. Cows that lie in the cow alleys are systematically tied up. From this point of time a hoof bath is applied twice per week. |
| 0 | All functionings are examined: Milking system, water trough, watering cup automatic feeder, etc. The cows stay permanently in the housing. |

Chapter 4

4.9 Literature

4.9.1 Sources

Anonym. 1991. Dyreværnslov lov nr. 386 af 1991. Justitsministeriet.

Anonym. 1997. Bekendtgørelse om ændring af bekendtgørelse om beskyttelse af kalve. Justitsministeriet.

Fraser, A.F., & D.M. Broom, (1990): Farm Animal Behaviour and Welfare. 3. edition. Bailliere Tindal, London, 437 pp.

Hemsworth P.H. & Coleman G.J., (1998): Human-Livestock Interactions (The Stockperson and Productivity and Welfare of Intensively Farmed Animals). 152 pp.

Krohn, C.C., 1996. The effects of early housing og dairy calves on the subsequent man-animal relationship. Proc. of the 30th Intern.Cong. of the ISAE, 14-17 Aug. Guelph, Canada. 109 pp (abstr.).

Seabrook, M.F., 1994. Psychological interaction between the milker and the dairy cow. National Mastitis Council Annual Meeting Proceedings, 163-173 pp.

Syme G.J. & L.A. Syme, (1979): Social structure in farm animals. Elsevier. 199 pp.

4.10.2 Supplerende litteratur

Anonym. 1994. Nødventilation og alarmanlæg, Landbrugets Rådgivningscenter. 34 pp.

4.9.2 Supplementary literature

Anonym, 1995. Arbejdsteknik og arbejdsmiljø i landbruget. Landbrugets Rådgivningscenter.

Anonym, 2000. Hvorfor går det så galt? - En film om arbejdsulykker i landbruget. Landbrugets Rådgivningscenter.

Blom, Jens Yde. 1999. Sunde klove - kommer ikke af sig selv. Landbrugets Rådgivningscenter. 27 pp.

CIGR Design Recommendations Dairy Cow Housing. 1994. Report of CIGR Section II. Working group no. 14 ADAS, Martyr Worthy Winchester, SO21 1 AP, England. 56 pp.

Dalgaard, I., 2000. Indkøring af stalde til kvæg. Landbrugets Rådgivningscenter. 43pp.

Krohn, C.C. 1995. Forskning i adfærd og velfærd. Husdyrvelfærd og husdyrproduktion. En rapport om forskning i velfærd for husdyr. Landbrugs- og fiskeriministeriet, Forskningssekretariatet. 28-46 pp.

Kromann, H., O. Kristensen, H. J. Andersen, J. Y. Blom. 1995. Når du skal bygge ny løsdriftstald. Anvisninger og checklister for indkøring. Landkontoret for Kvæg. 15 pp.

MC Donald, J.S. Radiographic Method for anatomic study of the eat canal: Changes between milking periods. AMJ vet res. 1975; 36: 1241-1242.

Nickerson, S. C., 1985. Immune mechanisms of the bovine udder: An overview. Journal of American Veterinary Medical Association, vol. 187:41.

Rasmussen, J.B., L. Jepsen, M.D. Rasmussen, S. Clausen, O. Kristensen. 1999. AMS - Automatiske malkesystemer. Landbrugets Rådgivningscenter. 26 pp. ISBN 87-7470-738-6.

5.1 Introduction – housing climate in general

Housing climate means the air in a cow house in terms of temperature, humidity, wind speed and air pollution in the shape of particles (dust and micro-organisms) and gasses. Acoustics and light conditions also form part of the housing climate (Valbjørn, 1995).

The dimensioning of the housing climate is based on the size and age of the individual animal groups, the production level as well as the staff who must work in the given farm sections.

The housing climate is influenced by the building design (geometry), volume, insulation, location of animals and heating, if any.

In specific farm sections and service rooms that must be frost-free and maintain a certain minimum temperature, insulation and heating can help ensure the desired housing temperature. At the same time ventilation can keep air humidity and pollution at an acceptable level. This section will not go any further into mechanical ventilation of insulated farm buildings. (Please consult professional literature for further information).

The housing wind speed is primarily determined by the design of the air inlet and its regulation. However, it is also to some degree affected by the heat production from the animals, air outlet, farm housing dimensions and the outdoor climate.

The following sections will deal with conditions of importance to a good housing climate.

5.2 Climatic requirements

When establishing climatic requirements for cattle buildings, animals as well as staff must be paid regard to. Climatic requirements that apply for the whole year for temperature, air humidity, etc. cannot be established as absolute requirements. Instead they must be established as climatic requirements for the winter climate (temperature, air

humidity and degree of pollution) and maximum requirements for ventilation during summer. The regulation of the amount of ventilating air between two extreme ends must ensure that the climate is kept within acceptable limits.

Generally, cattle are very climate tolerant. Production traits of dairy cattle are only influenced very little by temperatures from -15°C and up to $+25^{\circ}\text{C}$. Most of the year the housing climate requirements of dairy cows are met by a combination of the typical Danish climate and the application of farm buildings that provide shelter from sun, wind and rain.

The thermoregulation of cattle (their ability to adapt to the climatic conditions) will compensate for temperatures beyond the range of -15°C and $+25^{\circ}\text{C}$. In consequence, cows will increase feed intake and develop more fur when it is cold and reduce feed intake as well as supply a reduced milk yield and/or beef production when it is warm.

5.2.1 Temperature

Cattle can easily stand temperature fluctuations between -20°C and $+30^{\circ}\text{C}$. However, the temperature in Denmark is hardly ever beyond this interval. Thus there are no particular minimum requirements for cattle building temperatures in Denmark. Therefore, to ensure a good housing climate, a high degree of air change is recommended as well as keeping the temperature as low as possible during frost-free periods. Full-production animals can very easily stand subzero temperatures as long as conditions are dry and draught can be avoided. However, sick animals have difficulties in standing low temperature.

Draught may arise in housings with a high wind speed in the areas where cattle stay. The result of the wind supercooling, e.g. an outdoor temperature of 0°C and a wind speed of the wind that enters the farm housing of 11 m/s , will by humans be perceived as a cooling that corresponds to staying outdoor at -16°C .

5.2.2 Air humidity

The ratio of water vapour in air is normally expressed in percentage relative humidity (% RH). It is very rare that the air humidity will influence the well-being of cows in Denmark.

High relative air humidity is usual, if the farm building air is extremely polluted due to a low air change. This may further the development and spreading of environmental bacteria.

High relative air humidity requires higher amounts of litter, as it is difficult to keep the litter dry. Moist housing surfaces will result in a shorter life of the buildings or increased costs of maintenance.

5.2.3 Wind speed

From experience it is known that the wind speed in the part of the housing where cattle stay should not exceed 0.2 – 0.5 m/s. If this happens the ambient air temperature may result in an increased cooling of the surface temperature of the animal. This is the simple definition of draught. At the same time this means that higher air velocities than the above-stated 0.2 – 0.5 m/s during periods of higher ambient air temperatures might be perceived positively by cattle. In this situation the increased wind speed will result in a desired cooling of the surface temperature of cattle.

5.2.4 Precipitation

Precipitation e.g. in the form of snow and heavy shower should not occur in the resting area, as the litter will be moist and lose its insulation effect. Thus it will be very cold and unhygienic.

5.2.5 Gases

Carbon dioxide, ammonia and hydrogen sulphide will influence the housing climate. The amount of these gases in the housing air should be as low as possible. According to CIGR-1984 the animal welfare will be affected if the concentration of these gases exceeds the numbers stated in table 5.1.

5.2.6 Dust

Dust comes partly from cattle, litter, manure remains and from the feed. The content of dust in the air should be as low as possible. However, dust in the housing air is normally not a problem for cattle.

The limit value of total dust is 3 mg/m³ air for staffs that work eight hours per day.

5.2.7 Light

Well-lit farm buildings will influence cattle directly as indirectly. This is due to the fact that the length of the day (also the one established by artificial light) is the outer stimulant, which by means of hormones controls/synchronises the sexual behaviour and reproduction of cattle.

For dairy cattle a lighting system is recommended that changes between three levels: working light, orientation light and/or night light.

Illumination is dimensioned according to table 5.2. The numbers of the table are calculated on the basis of the assumption that lighting fittings are clean and that floors, walls and ceilings of the room reflect light to some degree. If the inside surfaces of the farm building and the lighting fittings are very dirty the lighting effect will be reduced (Anonym, 1997).

It is recommended that animals during the winter term should have about eight hours without light during night and an artificial day length of about 16 hours with working light.

Orientation light is recommended during the whole resting period in housings with reduced feeding area and in connection with automatic milking systems (AMS).

Night light (light to distinguish) during the resting period is recommended to reduce the risk of teat damage and unwanted unrest during nightly inspection visits.

Table 5.1. Recommendations for maximum accepted gas concentrations.

| Gas | Instr., max. concentrations according to CIGR |
|---|---|
| Carbon dioxide, CO ₂ ¹⁾ | 3,000 ppm |
| Ammonia, NH ₃ | 20 ppm |
| Hydrogen sulphide, H ₂ S | 0.5 ppm |

¹⁾ CO₂ should preferably be under 1,000 ppm in well-ventilated housing.

Source: Anonym, 1984.

Table 5.2. Recommendations for illumination, lux (Danish standard = DS 700).

| | Working light, lux | Orientation light, lux | Night light, lux |
|---------------------------------------|--------------------|------------------------|------------------|
| Feed alleys | 100 | 25 | 5 |
| Rung alley, (tied-up housing) | 100 | 25 | 5 |
| Resting area | 100 | 25 | 5 |
| Holding area | 100 | - | - |
| Milking parlour and milk storage room | 200 | - | - |
| Treatment and calving pens | 200 | 25 | 5 |
| Service room | 100 | - | - |

Orientation/night light is recommended during night hours. The illumination should not vary more than 50%.

5.2.8 Sound

Cattle's limit for acceptable noise level is unknown. However, when designing ceilings, especially in connection with the milking areas and service rooms, the farmer should aim at creating an acoustically pleasant environment, as sudden high sounds in certain parts of the farm housing will be unpleasant for both cattle and staff. As a consequence, they may be stressed.

5.3 Building insulation

Building insulation is applied in those parts of the housing that must be frost-free and, if necessary, heated. This may e.g. be the service or the milk storage room. The insulation of the rest of the constructions only serves the purpose of avoiding condensed water.

5.3.1 Insulated buildings

Recommendations

- From a farm building climatic point of view cattle do not make special demands on the degree of insulation.
- The function and maintenance of the building as well as the staff working conditions should form the basis of the choice of insulated construction
- The constructions must be carried out in such a way that condensed water does not occur on the inside building surfaces
- Normally, the bedding of littered cubicles needs no insulation out of consideration for cattle
- Farm buildings with a temperature of 10 – 15°C and a relatively high air humidity would, if the outer floor area is a cubicle, benefit from an ef-

fective edge insulation in the front part of the cubicle or foundation.

5.3.2 Uninsulated buildings

Recommendations

Uninsulated farm buildings are only to be recommended in connection with loose housing systems. However, insulation and heating should be established in the milking area to keep it frost-free.

In order to prevent condensed water from dripping from the roof surfaces, roof materials of a certain porousness or constructions that lead the condensed water to the outer side of the roof surface should be applied. Moreover, drinking water supply systems should be frost-proof.

Background and motivation

The climate of uninsulated farm buildings cannot really be controlled, and thus the temperature will follow the outdoor temperature changes. Moreover, the farm building air will be moister than the outdoor air.

Therefore uninsulated housing can never be kept completely condensation-free. Especially, cold, calm winter nights will make the roof surface radiate up-going heat. This means that the roof surface will turn colder than the air and hence condensed water occurs. Condensed water will, especially, occur in connection with sheet metal roofs as well as climatic changes from frosty to warm weather or the other way around.

5.4 Ventilation

Today new cattle houses are normally uninsulated and with natural ventila-

tion. Mechanical ventilation is applied in old insulated farm housings, in special houses for beef calves with a high weight gain and heat production, and in tied-up housing systems. Cattle in loose housing systems can to a certain extent avoid areas with draught during changing climate conditions. However, this is not the case for cows in cubicles.

5.4.1 Natural ventilation

Natural ventilation is partly based on thermal buoyancy and wind effects/winddrift. The thermal buoyancy is well defined and depends on the differences in temperature between air in the housing and outdoor air as well as the difference in height between air inlet and air outlet (the drift height). However, the wind effect is unpredictable and it varies considerably.

The concept "open housing systems" covers naturally ventilated housing systems, which are simply roofed buildings with outdoor climate. This system only serves the purpose of sheltering cattle from precipitation.

5.4.2 Dimensioning of natural ventilation

Recommendations

In order to ensure sufficient minimum ventilation in calm weather, large ventilation areas must be established.

Tables 5.3 and 5.4 state the dimensions of the heat production and the ventilation area based on the number of animals per group, age and production level as well as the drift height of the housing. This area should be available in connection with air inlet and outlet (Morsing, 1999).

In table 5.3 the number of cattle of each group is converted into heat production units (hpu).

Table 5.4 lists the ventilation area necessary in different housing systems, insulated as uninsulated with natural ventilation. The drift height is the dis-

Table 5.3. Heat production units (hpu) for different age groups and production levels.

| Weight kg/animal | No. of hpu/animal |
|--|-------------------|
| <i>Calves, 0-6 months</i> | |
| 50 | 0.12 |
| 75 | 0.18 |
| 100 | 0.23 |
| <i>Beef cattle, 6-15 months</i> | |
| 200 | 0.42 |
| 300 | 0.58 |
| 400 | 0.72 |
| 500 | 0.86 |
| <i>Rearers, 6-15 months</i> | |
| 200 | 0.37 |
| 300 | 0.52 |
| 400 | 0.65 |
| <i>First calvers/dry cows (1 month before calving)</i> | |
| 400 | 0.72 |
| 500 | 0.80 |
| 600 | 0.88 |
| <i>Dairy cows (20 kg, 4% milk/day, 3 mth. aft. insemination)</i> | |
| 400 | 1.08 |
| 500 | 1.16 |
| 600 | 1.24 |

Source: Morsing, 1999.

Table 5.4. Ventilation area in cm²/hpu in connection with different housing types. The area must be available both in connection with air inlet and outlet.

| Drift height, m. | Insulated | Insulated deep litter | Uninsulated | Uninsulated deep litter |
|------------------|-----------|-----------------------|-------------|-------------------------|
| 3 | 1,600 | 1,800 | 2,200 | 2,700 |
| 4 | 1,300 | 1,600 | 1,900 | 2,300 |
| 5 | 1,200 | 1,400 | 1,700 | 2,100 |
| 6 | 1,100 | 1,300 | 1,500 | 1,900 |
| 7 | 1,000 | 1,200 | 1,400 | 1,700 |
| 8 | 1,000 | 1,100 | 1,300 | 1,600 |

Source: Morsing, 1999.

Chapter 5

Figure 5.1.

Air dispersion in housing in which the sticking effect has been optimum utilised in connection with air inlet at the upper part of the wall placed directly against an inner roof carried out as an overhang. NB! Avoid projecting, shelter-providing wooden purlins – or curtain sidewalls under the roof – as they will most certainly ruin the sticking effect.

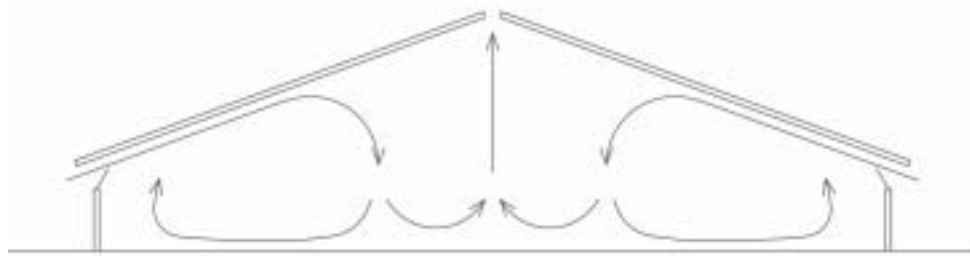

Figure 5.2.

Wind speed in full open-wall housings with a wind effect of 10 m/s (measured at 10 metres height) across the housing.

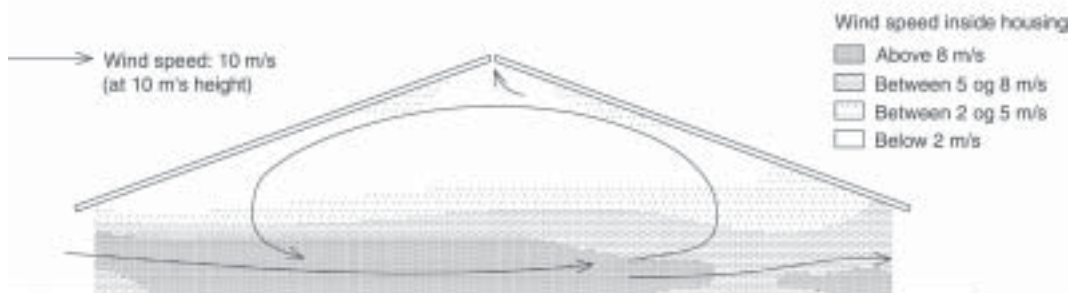

Figure 5.3.

Air velocities of a corresponding housing under the same conditions as in figure 5.2. However, in this case the housing is provided with a sidewall of 1.5 metres.

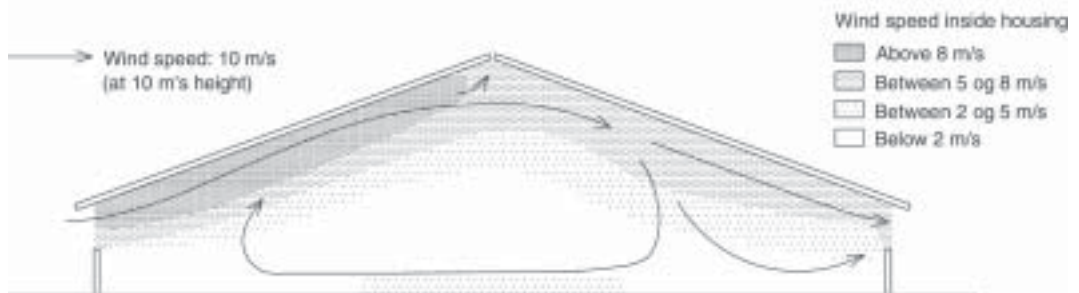
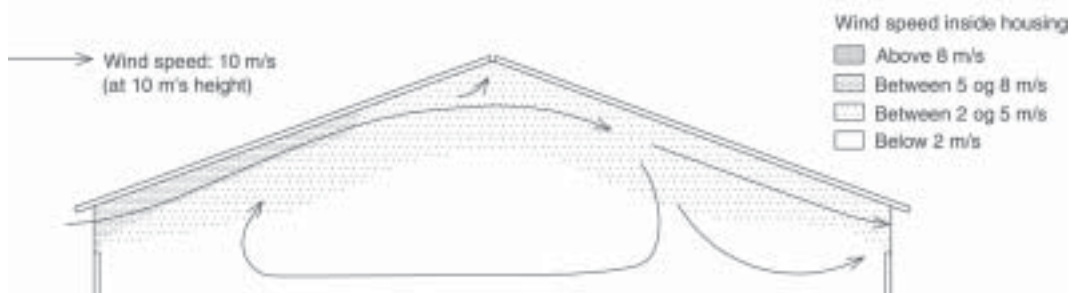

Figure 5.4.

Wind speed of a housing that corresponds to figure 5.3. The open part of the wall has been covered with a wind-breaking covering.



tance measured from the air outlet in the roof ridge to the middle of the air inlet in the sidewalls of the building.

Typically the air outlet is placed in the ridge of the roof, but never quite at the gable end. Air outlet should not be established in the last bay before the gable end or approx. four metres within the inside gable end/partition walls. This is recommended to avoid cold air intake in the animal resting area near gables/partition walls.

The basis of the dimensioning of ventilation openings in farm buildings without drift height (i.e. housing systems with a small roof slope and very limited openings in the roof ridge) is still under development.

The manure mat of deep litter housing systems emits large amounts of aqueous vapour and carbon dioxide, which results in increased ventilation need. Table 5.4. shows that the dimensioning of ventilation areas of deep litter farm buildings is approx. 30% larger than ventilation areas of building systems without deep litter.

Background and motivation

It is an advantage that the air inlet of insulated farm housings can be adjusted to approx. 10% of the area dimensions of table 5.4. during cold periods. It should thus be possible to keep the farm building frost-free. Often adjustment of air inlets is not necessary or practically possible in uninsulated housing systems. The fact that uninsulated farm buildings cannot be 100% frost-free anyhow should be accepted.

If the air inlets are designed as shown in figure 5.1, it is possible to utilise a sticking effect created against the inside roof surface as long as the air is taken in along a flat inside roof. This effect can only be achieved in uninsu-

lated housing systems if the first two to three metres of the ceiling are made as an insulated and covered inside roof.

Totally open housings without walls run the risk of too high air velocities in the areas where cattle stay. Figure 5.2 shows an example of air velocities that may occur in totally open cattle buildings with a traverse wind force of 10 m/s measured at a height of 10 metres.

If the ventilation openings are reduced by a 1.5 metre high wall, the conditions will be changed considerably at the same wind force. This is evident from figure 5.3.

Further shelter could be provided by mounting wind-breaking covering in the open part of the walls. This is shown in figure 5.4.

The covering could e.g. be wind-breaking plastic nets, perforated steel plates, slot-shaped gill slits or space boarding. If a wind-breaking material with too big holes is chosen, heavy shower may enter the farm building and perhaps the resting areas.

When a wind-breaking covering is chosen, the open area is reduced depending on the qualities of the material. The size of the ventilation area, calculated according to table 5.4, must be increased, correspondingly, to obtain a sufficient ventilation.

Wind-breaking coverings must be kept intact and the opening degree should be the same as when mounted. Condensation humidity and airborne dust may fasten to the covering and reduce the opening area and hence the covering material must stand cleaning. Experience shows that space boarding and perforated steel plates stand this treatment.

Chapter 5

5.5 Literature

5.5.1 Sources

Anonym. 1984. Climatization of Animal Houses, rapport fra CIGR-arbejdsgruppe. Scottish Farm Buildings Investigation Unit. Aberdeen, Skotland. 72 pp.

Anonym. 1997. DS 700. Dansk Standard. 2 pp.

Morsing S., Zhang G. og Strøm J. S. 1999. Naturlig ventilation af stalde: Dimensionering, Grøn Viden nr. 13. Danmarks JordbrugsForskning, Forskningscenter Bygholm. 6 pp.

Valbjørn O. et. al. 1995. Indeklimahåndbogen. SBI-Anvisning 182. Statens Byggeforskningsinstitut Del 1, 17-28 p.

5.5.2 Supplementary literature

Anonym. 1992. Climatization of Animal Houses, II, rapport fra CIGR-arbejdsgruppe. Centre for Climatization of Animal Houses, University of Gent, Belgien. 147 pp.

Anonym. 1994. Aerial Environment in Animal Housing, rapport fra CIGR-arbejdsgruppe. Groupement de Pennes. Rennes, Frankrig. 16 pp.

Anonym. 1995. Indretning af stalde til kvæg - Danske anbefalinger, 2. udgave. Landbrugets Rådgivningscenter. 192 pp.

Eskholm, T., Korsholm, K., Pedersen S. og Pedersen N. 1998. Klimateknik - i landbruget. Landbrugets Rådgivningscenter, Landbrugsforlaget Skejby. ISBN: 87 74 70 684 5. 152 pp.

Hansen, K. 1991. Løsdriftstalde med dybstrøelse til malkekøer, Orientering nr. 75. Statens Jordbrugstekniske forsøg. 42 pp.

Strøm J.S., 1999. Åbne stalde, Grøn Viden nr. 16. Danmarks JordbrugsForskning, Forskningscenter Bygholm. 6 pp.

Strøm J.S. Morsing S. og Zhang G. 2000. Vindbrydende beklædning af vægåbninger i naturligt ventilerede stalde, Grøn Viden nr. 17. Danmarks JordbrugsForskning. 6 pp.

Selection of equipment and materials

Equipment, walking alleys and drinking water system must be designed in such ways that they meet the needs of cattle. The most suitable materials for the given purposes must be applied.

Since 1994 it has been a legislative requirement in Denmark that an equipotential bonding (supplementary equipotential connection) must be established to protect the cattle when building cattle housing systems. It is extremely important that this equipotential bonding is carried out correctly as potential differences between the different building parts may cause stress among cattle.

6.1 Equipment

Definition

The primary purpose of farm equipment is to design and demarcate the areas where cattle are kept. The term equipment covers cubicle partitions, gates, pen partitions, feeding racks, troughs, neck rails, front rails, brisket boards, watering cups and water troughs, distance rails as well as milking parlour/holding area equipment.

Design

The equipment must be designed in such a way that animals can maintain a considerable degree of welfare without running the risk of being hurt.

Moreover, the equipment should enable animals to place themselves in natural positions when drinking, eating, exercising or resting. The equipment design should not lead to tearing off of ear tags, transponders or the like. Finally, the equipment design should not cause any openings in which animals can get stuck.

Recommendations

Angles of less than 90° should be avoided as well as narrow cracks in connection with joints. Bolts and screw heads should be countersunk or in some other way "hidden". Concrete must be cast around the posts in order to keep the post clean and dry. The surfaces of all the equipment should be smooth and rounded off. Thus only small amounts

of dust, dirt and moist will be deposited. Moreover, equipment with smooth and rounded surfaces is easy to clean.

6.2 Floors

Floors must stand the occurring mechanical and chemical loads and must additionally be moist-resistant – in case of outdoor facilities, the floor must also be frost-resistant.

6.2.1 Recommendations for solid floors

Surface conditions as regards solid floors

Walking areas must be slip resistant and the surface must be as gentle to cattle as possible. Slippery floors may cause cattle to fall and lead to subsequent injuries. Rough floors may result in knee and leg injuries as well as worn-down hoofs.

The bedding area must both be slip resistant and dry. A dry bedding area can be obtained by means of an appropriate downward slope and a small amount of litter or a slopeless bedding area with a large amount of litter.

In this way it is possible for cattle to emit heat and moist from their skin and also from the parts of the body that touches the bedding. If the contact surface is both humid and warm, the risk of pressure injuries and sores increases (for further information, please see chapter 9 concerning cubicles and deep litter for dairy cows, and chapter 8 about cubicles and deep litter for young stock).

Walking alleys with solid concrete floors must be established with broomed or profiled slip resistant surfaces. Different profiling examples are depicted in figure 6.1. Moreover, the purpose of profiled surfaces is to lead fluids from floor to drain, so the floor is kept as dry as possible. If other materials are applied brooming and profiling may be omitted, if the material is slip resistant. This material may e.g. be hot rolled asphalt.

New concrete floors may be so rough that they cause an extremely harsh hoof wear as well as hair and skin wear off on hocks and knees. Thus walking alleys must be coated before the housing is taken into use. This may e.g. be done by applying an asphalt product to the floor, which is sprinkled with sawdust while it is still wet. Some asphalt products contain cork or rubber granulate, however, sawdust should still be applied.

Concrete in front of trough elements may with advantage be protected against erosion. If the trough bottom is made of concrete, the farmer should choose a strong concrete type, which is tight and intended for an aggressive environment.

Milking centre floors

The floor of the operator pit/milking alley and milk storage room must be equipped with a coating which can stand mechanic and chemical loads. The coating may e.g. be oblong floortiles or flags of polyester concrete, epoxy, hot rolled asphalt or the like. The space between floor and wall should be protected against moist penetration, e.g. by pointing an acid-proof joint sealant or by coating the surfaces with an acid-proof product.

The concrete floor of the operator pit/milking alley is very hard and loading for the milker to walk on. Thus it is recommended to apply an elastic grid or mat for the milker to stand on while milking. The grid may be adjustable to provide the milker with the optimum working height and it should be made of acid-proof materials, e.g. plastic and acid-proof stainless steel.

It should be easy to clean under the grid. The floor under the grid could e.g. be built with a 10% slope towards an open centre drain, which channels liquid to a pump sump or by means of a water trap to another pump well.

The milking stall floor must be slip resistant and the surface should be as gentle as possible to the cow's legs. Concrete floors must be coated e.g. with an epoxy product to which sand is added. If other slip resistant materials are applied, the coating may be omitted. Thus hot rolled asphalt must not be coated.

The stall floor should slope 2% towards a drain away from the edge of the operator pit. The drain must be cleaned after each milking and it is a good idea to keep it open.

Other coatings than the ones mentioned in this section may be applied if they stand mechanical and chemical effects.

Strength and tightness in connection with solid floors

Floors should stand loads of animal, human and machine.

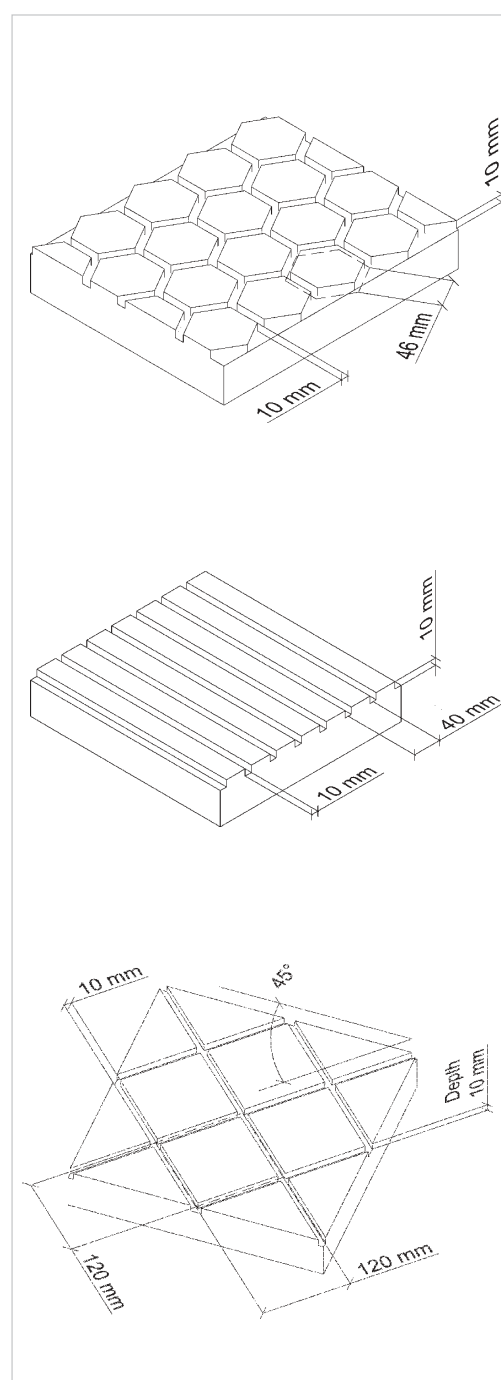

Figure 6.1.
Different profiling
examples of walking
alleys with solid con-
crete floor.

Chapter 6

Moreover, the floors should be made of a durable material, which is not easily penetrated by moist.

Normally, the requirements for floor construction as well as the tightness and strength of slurry and manure channels are met, if the construction is carried out as stated in "Landbrugets Byggeblade" (technical construction instructions) issued by the Danish Agricultural Advisory Centre.

6.2.2 Recommendations for slatted floors

Slatted floor serves the purpose of maintaining a clean and dry floor. It should be designed in such a way that the hoof and legs are not injured when cattle tread the manure, urine, litter and feed remains through the slots.

It is recommended that slatted floor elements are coated with an asphalt product and sprinkled with sawdust, while the asphalt is still wet, and before the slatted floor is taken into use.

The slot may with advantage lead all the way to the rear kerb of the cubicles. Thus manure is prevented from gathering.

Table 6.1. Recommended walking surface and slot dimensions in connection with slatted floors.

| | Walking surface width, mm | Slot, mm |
|-----------------------------|---------------------------|----------|
| Calves | 80 | 20 |
| | 100 | 25 |
| Young stock and beef cattle | 100 | 30 |
| | 120 | 35 |
| Cows | 120 | 35 |
| | 140 | 40 |

Walking surfaces and tolerances

The completed slatted floor must have a plane walking surface as well as rounded off edges and each slatted floor element must be floored steadily.

The floor surface of the elements must be protective and slip resistant for animal and man. Slatted floors with narrow walking surfaces are easiest to clean while wide walking surfaces promote hoof and leg health. In practise a lighting percentage of 20 – 30% of the slatted floor has proven appropriate. Table 6.1 lists the recommended walking surface and slot dimensions in connection with slatted concrete floors.

The difference in level between each slatted floor element, which lies next to each other, should not be more than three millimetres. The slots should not vary more than +/- 10%, however, they should not vary more than +/- 3 millimetres. This is also the case for slots that appear between slatted floor elements. Prior to delivery from factory burrs and sharp edges must be removed, if any. For information about the dimensioning background of concrete slatted floor elements, please consult "Landbrugets Byggeblade" (technical construction instructions): "Product requirements for concrete slatted floor elements" (Anonym, 1999a).

For further information, please consult DSK – Dansk SpaltegulvsKontrol (Anonym, 1999a), a Danish slatted floor control body, which attempts to ensure a high level of quality of concrete slatted floor bars/elements. Figure 6.2 depicts an example of a "Dansk SpaltegulvsKontrol" label.

6.3 Drinking water supply and allocation

Table 6.2. states in which way watering cups should be placed and the number of cattle recommended per metre water trough.

Recommendations

Tied-up housing, treatment pens, calving pens and pens in general:

It is recommended to mount one watering cup per animal in tied-up housing systems. If a cup unintentionally ceases to provide water, the cow is able to drink of the neighbouring cup.

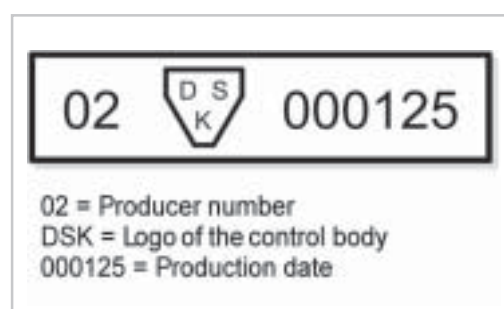

Figure 6.2.
Example of a "Dansk SpaltegulvsKontrol" label.

Table 6.2. Drinking place design.

| Animal weight, from kg | 100 | 200 | 300 | 400 | 500 | 600 | 700 |
|---|------------|------------|------------|------------|------------|------------|------------|
| Watering cup upper edge max. height above standing place, m | 0.5 | 0.5 | 0.6 | 0.6 | 0.7 | 0.7 | 0.7 |
| Number of animals per watering cup | 10 | 10 | 8 | 8 | 6 | 6 | 6 |
| Number of animals per metre water trough | 20 | 17 | 13 | 12 | 11 | 10 | 10 |
| Water trough upper edge height above standing place, max., m | 0.6 | 0.7 | 0.8 | 0.8 | 0.9 | 0.9 | 0.9 |
| Landing width, m (from water trough edge to landing edge towards alley) | 0.4 | 0.4 | 0.4 | 0.4 | 0.5 | 0.5 | 0.5 |
| Landing height, m | 0.15 | 0.15 | 0.15 | 0.20 | 0.20 | 0.20 | 0.20 |

Pens must provide two drinking opportunities and thus at least two watering cups. The cups can e.g. be mounted in the divisions between two pens allowing cows from both pens to drink from them.

The dimensioning of water supply in connection with watering cups must allow a water yield of minimum 10 litres per minute/cup when 20% of the herd drinks at the same time.

A watering cup should have an opening of at least 0.06 m², approx. 30 centimetres in diameter, or a similar opening size. A flat and wide watering cup is preferred. However, the cup must be so deep that the cow can keep the whole muzzle three to four centimetres under the water when it drinks. It should not be possible to empty watering cups for calves completely.

Loose housing systems

It is recommended to apply water troughs instead of watering cups in loose housing systems. There must always be two water troughs per group of animals. Thus the drinking opportunities of low-ranking cows are good.

Each water trough should be able to hold 200 – 300 litres of water and the water supply should be at least 10 litres per minute.

The volume of water troughs can be reduced to about 100 litres if the installation of water is dimensioned according to a volume flow of 15 – 20 litres per minute.

Location of watering cups and water troughs

Watering cup:

The watering cup is placed above the trough or feeding area in pen partitions preventing water from being spilled on the resting area. The height above floor of watering cups in connection with different groups of animals, is stated in table 6.2, and the number of animals allowed per cup is also stated.

Water troughs:

Water troughs are placed ideally in crossovers or at the feeding area in connection with the feeding rack. Free space should be provided around the drinking place allowing other cows to pass the drinking cows. Table 6.2 lists the recommendations concerning the placement and free space around a drinking place. The water troughs should be 0.2 – 0.3 metre deep.

In order to minimise the amount of manure in the water, water troughs/cups should be placed on a landing, depicted in figure 6.3, as cattle will never ascend a platform with its hind legs. Another solution could be to mount distance rails as shown in figure 6.4. However, this solution does not totally prevent water pollution.

Table 6.2 lists the recommended dimensions for landings on which cows stand with their forelegs while they drink. Alternatively the landing can be 0.3 metre broad only, and thus cows are not able to stand on it while drinking. This landing also prevents cows from defecating in the water troughs. The above-mentioned landing may be replaced by a distance/guard rail as depicted in

Chapter 6

figure 6.4. The platform height is stated in table 6.2.

Types of water supply

It is recommended that the main of the water supply is ring-connected and that the water is under a constant pressure. The water of water troughs/cups is supplied by the main via a short service pipe. This will make sure that fresh water is always supplied.

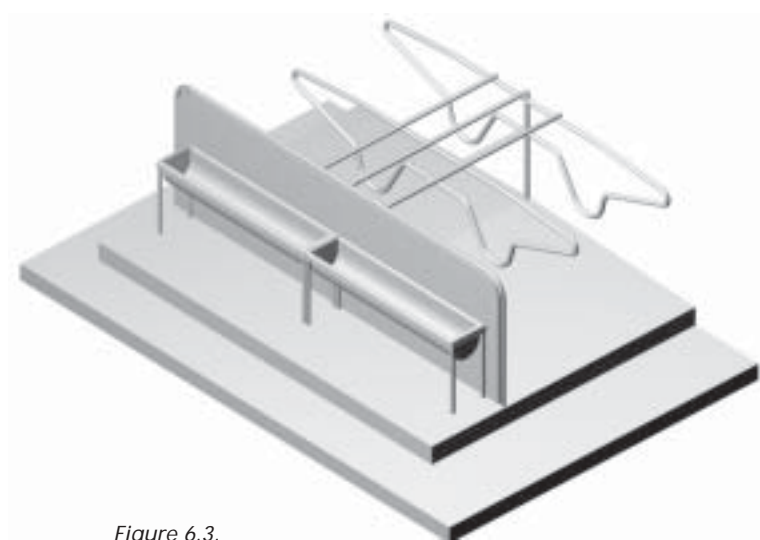

Figure 6.3.
Water trough design
where the trough
foundation has been
provided with a
landing.

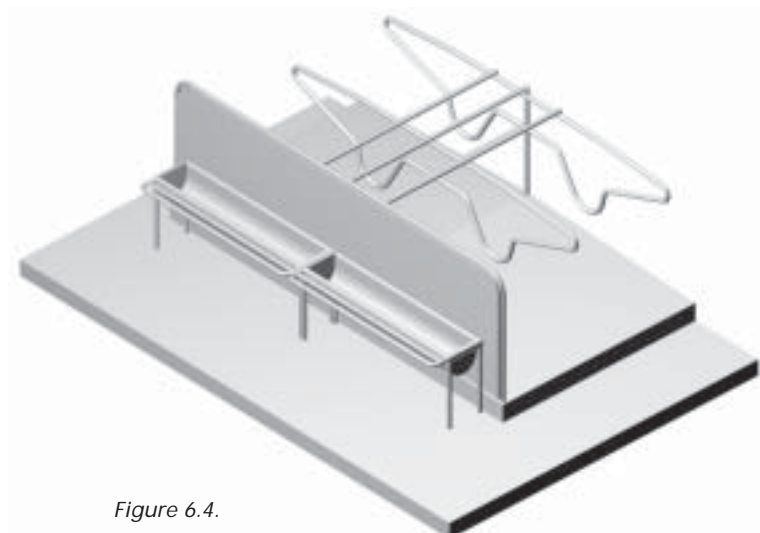

Figure 6.4.
Water trough design
including distance
rails.

It is not recommended that water troughs are directly connected, as dirty water will be led from one water trough to the next.

Frost control

Every water supply plant of the farm housing must be frost-proof. A water main can be frost-proof by mounting a circulation pump and perhaps an electric heating cartridge element in the water plant.

Hygiene

Dirt in the form of manure, urine and feed remains cannot be avoided in water troughs and watering cups. Thus water trough and cup should be designed in a way that as little dirt as possible is collected. Moreover, the design should facilitate cleaning. A big drain may e.g. be mounted in the water trough or it should be possible to tilt out all the water at the same time. A water trough with rounded off bottom and sides is easier to clean than a water trough with sharp edges/corners.

General information

It should be possible to water cattle if the normal water supply fails. Water from water troughs as watering cups should be prevented from returning to the water main installation.

It is recommended to apply water meters and filters (to remove dirt) to the supply mains of each farm section. The water meter allows the farmer to register the water consumption continuously and thus he will be able to detect a waste of water quickly, if any.

It is recommended periodically to check up on the water consumption by registering the daily consumption.

The design of water troughs and cups should prevent cattle from getting hurt.

Background and motivation

Abundant drinking water of a high quality is crucial for the milk yield and health of cattle. High-performance cows drink up to 100 litres of water per day and night.

It is difficult to avoid manure and urine completely in water troughs and cups of loose housing systems. Besides they will get dirty anyway from the feed re-

mains on cow muzzles. Thus it is necessary to clean water troughs and watering cups regularly.

If one cup is provided per cow in tied-up housing systems, each cow will have two drinking opportunities. Thus if one cup is not working, this will not influence the milk yield negatively.

When the water supply of watering cups is reduced to less than 7 litres per minute, the drinking frequency as well as the total drinking time will increase.

In order for cows to carry out their natural drinking (sucking) behaviour the height of the water surface must allow cows to keep their heads in an angle of 60° measured from the water surface (horizontal). The cup opening should be at least 0.06 m².

The cow will assume a natural drinking position when the water surface is 0.70 – 0.80 metre above the bedding (dependent on the breed). If neck rails are applied in connection with the water supply, e.g. in tied-up housing systems, it may be necessary to reduce the height to avoid that the rail disturbs cows when they drink.

If two cows must share a watering cup, e.g. in tied-up housing, there is a risk that the lowest-ranking cow will drink less water than the dominating cow, and thus the milk yield will decline accordingly.

6.4 Materials

6.4.1 Choice of materials

Farm equipment must be made of materials that stand loads of cattle, implements, and cleaning. The equipment loading depends on the function and placement of the equipment in e.g. milking parlours, alleys, resting areas, in connection with feeding racks, etc.

When choosing materials the durability should be considered as well as maintenance time and costs. The durability of the equipment e.g. depends on the thickness and quality of the material. The equipment must stand the necessary cleaning, which varies according to function and placement.

Farm equipment can be made of the following materials: Steel, stainless steel, concrete, wood, plastic, aluminium, etc.

Recommendations

Posts and steel tubes for feeding racks, cubicles and partitions should have a minimum thickness of four millimetres. The dimensions of finishing components placed in exposed places and particularly aggressive environments, e.g. the foot of supporting posts, should be extra solid. They could e.g. be made of a massive material.

6.4.2 Surface treatment

The surface loading is very heavy in farm environments. The chemical environment is relatively aggressive and the mechanical loading of tools and technical facilities is large as is the equipment wear caused by cattle. Rust and corrosion of steel equipments reduce the chances of maintaining a good farm environment.

Coating experiments show that different methods may to some degree protect equipment as well as cattle. Damage caused by corrosive attack can be limited by choosing suitable dimensions and materials as well as a corrosion preventing coating. A combination of normal steel and stainless steel is an excellent solution, if the stainless steel is applied where the risk of corrosive attacks is highest.

Recommendations

Coating must always be carried out according to the recommended instructions of the product. E.g. coating of concrete should not be carried out before the concrete has hardened sufficiently. Likewise, the coating must also harden sufficiently before the premises are taken into use. In order to achieve the desired effect, the coating must be carried out carefully.

Possible coatings:

- Galvanisation
- Coating of synthetic materials: Epoxy, polyurethane, acrylics
- Painting
- Farm asphalt.

6.5 Equipotential bonding

According to the Danish heavy current Regulation ("Stærkstrømsbekendtgørelsen") (Anonym, 1993) equipotential bonding (supplementary equipotential connection) must be established in all farm buildings. This also applies to all housings and rooms, with installations, in which feed, litter and manure is handled and stored.

Chapter 6

An installation equipotential connection is a protective conductor, which ensures an equipotential bonding. The equipotential bonding should prevent resistive faults in connection with strokes of lightning as well as electric installation defects and damages. Equipotential bonding is a part of the total protection measures against fault current and should be compared with fuses and fault circuit-breakers. In practise this means that all electricity conducting parts of the housing (equipment, gratings, steel rafters, milk pipes, etc.) must be connected to a joint grounding connection.

Recommendations

Equipotential bonding must be carried out correctly to protect cattle. A correct equipotential bonding will also eliminate potential differences between different buildings, which may cause stress among cattle.

All equipment that has been cast into the floor, e.g. posts, should be protected against galvanic corrosion in the zone between floor and post.

Figure 6.5 and 6.6 show examples of equipotential bonding carried out in cubicles and a milking parlour.

Background and motivation

Cattle have a low inner resistance and are able to sense very low amounts of voltage and current. Normally, cattle react to a current intensity of less than 5 – 7 milliamperes and a voltage intensity of at least 4 – 10 volts.

By connecting all electricity-conducting parts of the housing, the risk of galvanic corrosion in the zone between floor and post, if the posts are cast in, increases. Thus in order to prevent galvanic corrosion this zone must be kept dry. This can e.g. be done by casting concrete around the posts and apply a collar of e.g. shrink plastics to the post. Alternatively, a circle of at least 15 centimetres from the post can be coated as well as a minimum of 15 centimetres of the lowest part of the post. The coating may consist of epoxy, farm asphalt or similar products.

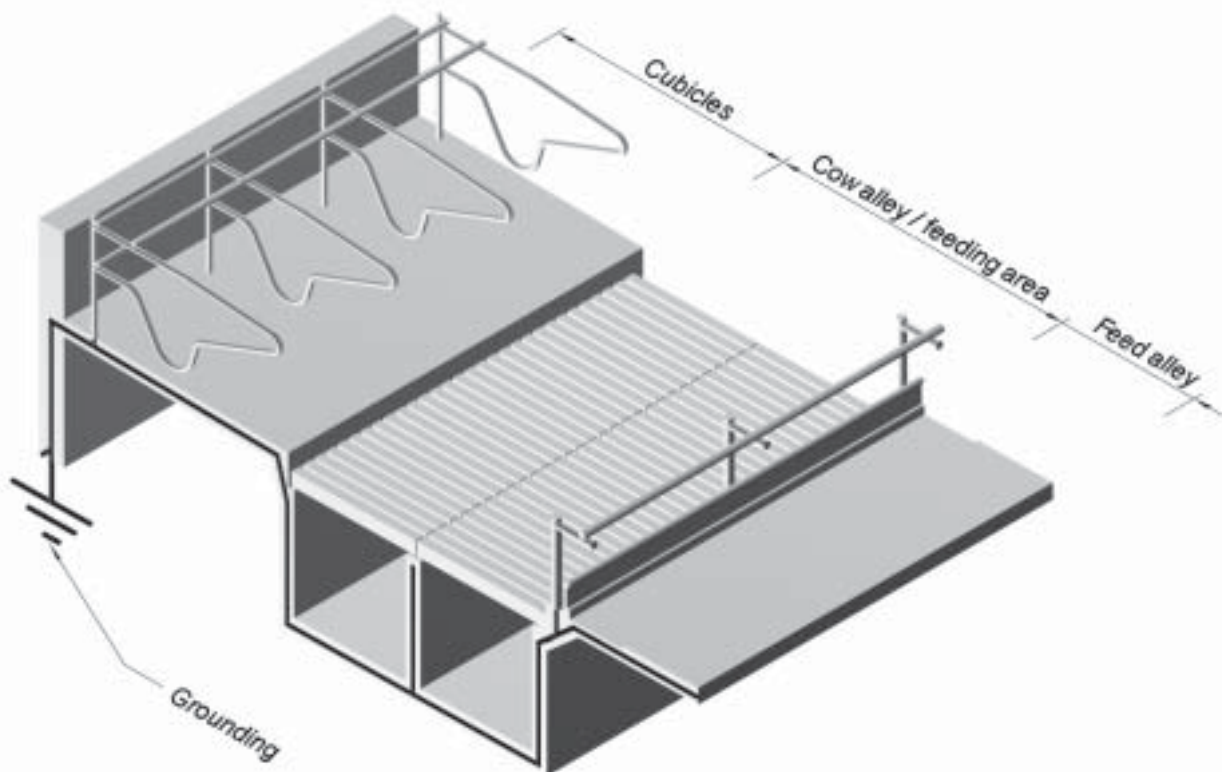

Figure 6.5.
Example of equipotential bonding in cubicle housing system.

By choosing like materials, e.g. galvanisation of equipment as well as steel rafters, arming and earth cables, the risk of galvanic corrosion may also be reduced.

6.6 Cleaning

It should be possible to clean equipment thoroughly, which is crucial to the durability of the product. By maintaining a good hygiene in the farm housing the equipment and building construction elements will last longer.

Cleaning is the most simple and effective way to reduce corrosive attacks of e.g. the attachment points of equipment (eliminate feed remains and manure).

Cleaning must be adjusted to those animals that are kept in the housing. Regularly cleaning will also have a positive influence on the well-being of cattle.

The equipment must stand water, cleaning agents and disinfectants that are normally applied and recommended.

The equipment must have a smooth – perhaps tight – surface, which is easy to clean and does not attract moist and dirt. The equipment must stand mechanical, high pressure and steam cleaning as well as disinfection, dependent on its function and placement.

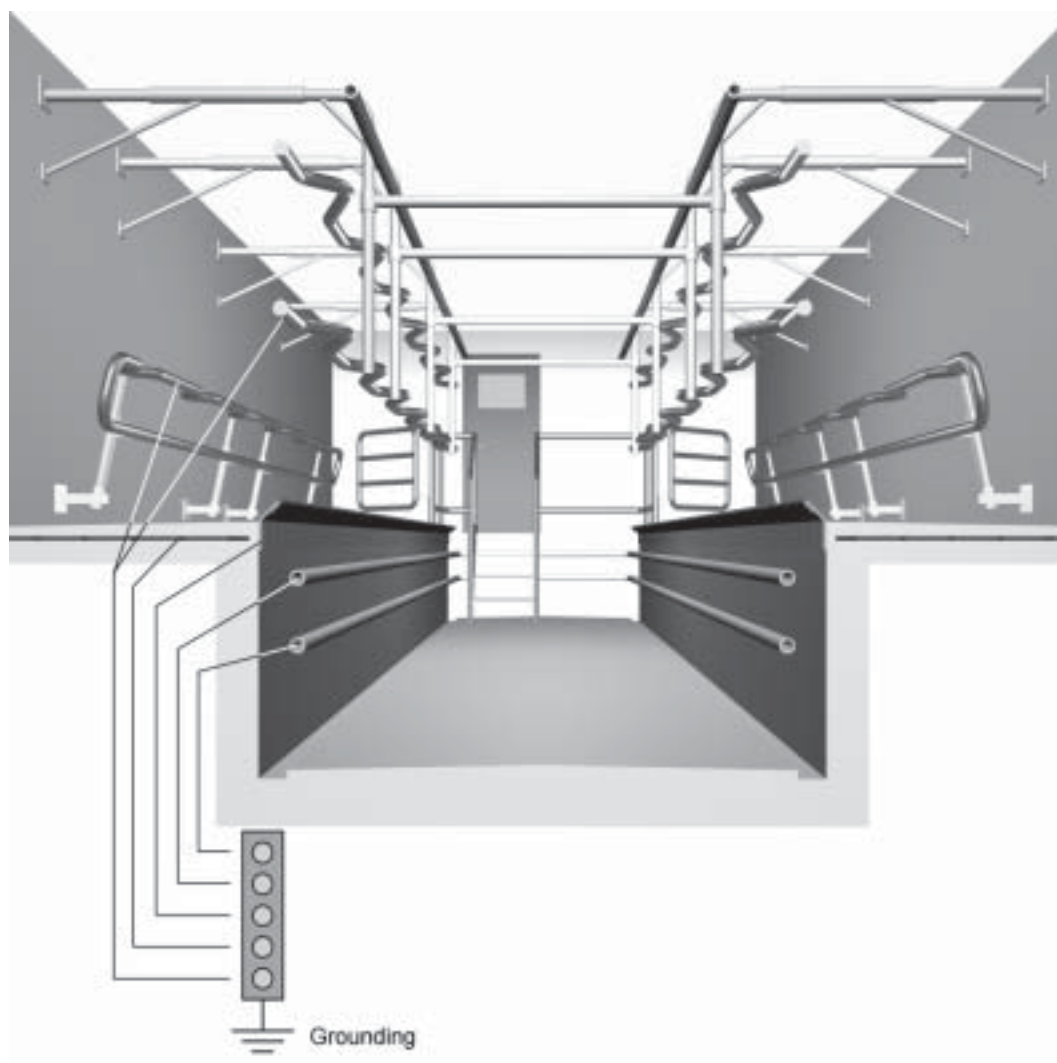

*Figure 6.6
Example of equipment potential bonding in milking parlour.*

Chapter 6

6.7 Literature

6.7.1 Sources

Anonym. 1993. Stærkstrømsbekendtgørelsen, elektriske installationer. 1. udg. Elektricitetrådet. København. ISBN 601-3745-2.

Anonym. 1999a. Landbrugets Rådgivningscenter: Landbrugets Byggeblade grp. nr. 102.09-21. Produktkrav for spaltegulvelementer af beton. 6 pp.

Anonym. 1999b. Dansk SpaltegulvsKontrol: Vedtægter samt øvrige bestemmelser.

6.7.2 Supplementary literature

Andersson, M. 1984. Drinking water supply to housed dairy cows. Institution för husdjurens utfordring och vård. Sveriges Landbruksuniversität, 123 pp.

Anonym. 1994. The design of dairy cow Housing, Report of the CIGR section II, working group no. 14. ADAS Bridgets Dairy Research Centre Farm Buildings Research Team. 56 pp.

Anonym. 1995. Byggeinformation: EI-installationer i landbrug, potentialudligning. Landbrugets Rådgivningscenter, Skejby. 7 pp.

Anonym. 1997. Dairy Freestall Housing and Equipment. 6. udg. MWPS-7. Iowa State University, Ames, Iowa. 136 pp. ISBN 0-89373-087-4.

Beck, J., D. Katzschke, T. Jungbluth, and H. Steingaß. 2000. Warm versus cold drinking water for dairy cows - influence on water and feed intake, performance and behaviour. EurAgEng. Warwick.

Gjestang, K. E. & K. A. Løken. 1980 Friksjonsforhold på bås-golv av betong og gummi. 161. Stensiltrykk. Inst. for bygn. teknikk. NLH. Norge. 17 pp.

Groth, W. & H. J. Eischler-Steinhauff. 1978. Haltungsbedingte Schäden beim Milchvieh. Fortschritte der Veterinärmedizin 28:12:34-43.

Olsen, N. O. 1985. Vandinstallationer i kostalde. SBI-landbrugsbyggeri nr. 65. Statens Byggeforskningsinstitut. 50 pp.

Olsen, N. O. 1984. Vandinstallationer til malkekøen - betydning og løsninger. 588. Beret. Statens Husdyrbrugsforsøg. 194-210 pp.

Reinemann, D. J., S. D. LeMire, M. D. Rasmussen, M. C. Wiltbank, & L.G. Sheffield. 1999. Comparison of behavioural and physiological response to electrical shock in lactating dairy cows. ASAE paper no. 993154. American Society of Agricultural Engineers, ST. Joseph, MI, USA. 23 pp.

Rosengren, B. og A. M. Sundahl. 1991. Drickvatentilldeling Till Mjölkkor, LBT Specialmeddelande 186. Sveriges Lantbruksuniversitet.

Sundahl, A. M. 1988. Fövärmning av Dricksvatten till Mjölkkor. LBT Specialmeddelande 164. Sveriges Lantbruksuniversitet.

Weeb, N. G. & C. Nilsson. 1983. Flooring and injury - an overview. In: Baxter, S.H., M. R. Baxter & J. A. C. MacCormack (eds.) Farm animal housing and welfare. Nijhoff. 200-214 pp.

Calving section – sucking calfs

7.1 Calving

Calvings should take place in calving pens at a place that the staff passes frequently during the day. Thus the staff will have a good contact with the other part of the herd and at the same time they can easily look after cow and calf. It is recommended that calf and cow are kept together alone the first 24 hours after the birth. The calving pen must be clean and freshly littered prior to each calving.

The cow should not be tethered in the calving pen, as it should be able to move around naturally during the calving and lick the calf when its born. In case of para-tuberculosis or salmonella on the farm, the calf must be removed from the calving pen as quickly as possible after calving.

Even though cow and calf stay together after calving it is necessary to check that the calf quickly suckles colostrum and it may also be necessary to help it find the teats. In joint calving pens

there is a risk that the new-born calf suckles from other cows than its mother. Thus the farmer should make sure that each calf receives enough colostrum from its mother as soon as possible and within 6 hours after calving.

7.1.1 Calving pen

One calving pen is recommended per 30 cows at even calving intervals. Table 7.1 lists the calving pen dimensions.

If down-calving cows are kept in joint pens, 8 m² per cow is recommended. It should be possible to isolate an area of 10 m² for the calving. Moreover, a calf shed should be established (see figure

Table 7.1.

Calving pen dimensions

| | |
|-------------------------------|------|
| Area, min., m ² | 10.0 |
| Pen width and length, min., m | 3.0 |
| Pen side height, min., m | 1.3 |



Figure 7.1.
Commodious and
straw-littered calving
pen which can
easily be accessed.

10.1, chapter 10). This enables the calf to stay and rest on its own without being disturbed by the other cows.

Separation

Partition walls should be built as an open construction with a maximum of 10 centimetres between the vertical bars. It should be possible to remove the partition walls in case of emergencies. There should be a gate or a man-hole in each pen, which allow persons to enter the calving pen. Figure 7.1. depicts a calving pen.

Feeding rack

The feeding rack should prevent calves from getting out of the pen and at the same time allow cows to eat and drink. It should be possible to move a cow that is lying down to or from the pen through a front gate. Moreover, it should be possible to fix cows in the calving pen.

Floor

The pen floor must be slip resistant and each pen should include an independent drain. Thus the calving pens can be cleaned individually. Moreover, the pens must always contain fresh litter. Sand bedding under the litter makes the floor particularly slip resistant and this deformable sand bedding will be even more comfortable for cows to lie on. A minimum of 30 centimetre sand must be applied.

Feeding area

The same as in the rest of the housing system.

Drinking water

Please see section 6.3 in chapter 6.

Milking

It should always be possible to milk cows in the calving section/pen.

Light

The calving pens should always be well lit (200 lux).

Background and motivation

Behaviour

Calves need to lie on dry bedding and they should not be disturbed by other cows (new-born calves lie down 16 – 18 hours per 24 hours). The calf needs physical contact with its mother. The cow has a great need to lick its new-born calf (Edwards and Broom, 1982).

The licking of the calf stimulates its senses and motor apparatus to activate themselves quickly and the suckling activity has a positive effect on the after-birth expulsion (Edwards, 1982).

The urge of the cow to lick the calf may cause stress, if she can see and hear the calf, but is prevented from getting at it (Michanek, 1994).

“Cross suckling” means that a calf suckles from another cow than its mother. This behaviour occurs relatively frequently in joint calving pens, especially among first calvers. Thus there is an increased risk that the calf may not suckle enough colostrum (Michanek, 1994).

If the mother-calf bonding, which is established through visual and physical contact during the first 24 hours after the calving, is severed after four to five days it will strain the cow more than the calf (Krohn, Jonassen & Munksgaard, 1990).

During the first week after the birth the calf suckles milk 5 – 8 times per day (Krohn and Madsen, 1985). Moreover, calves almost never eat solid feed during the first week (Swanson and Harris, 1958).

Health

Calves are born without any antibodies to protect them from infectious diseases. Colostrum contains antibodies. Thus the calf depends totally on its ability to suckle colostrum quickly after its birth especially as the intestinal wall is only able to absorb colostrum antibodies during the first 24 hours after the calf is born (Blom & Jensen, 1996).

The power of resistance of calves is influenced by the following conditions:

- The physical contact between calf and cow during the first 24 hours after the birth influences the ability of the intestine to absorb antibodies from the colostrum positively (Selman et al., 1971a and 1971b)
- It is no guarantee that calves that are kept in pens together with their mothers suckle colostrum within the first six hours of their lives. This may especially be difficult for the calf if the cow is nervous or the udder hangs very low (Edwards, 1982; Selman et al., 1970; Broom, 1983)

Chapter 7

- An optimum immunity is achieved if cow and calf are kept together the first couple of days after the birth, and if the first colostrum is supplied manually (e.g. by means of feeding bottle) within the first six hours of the calf's life (Blom et al., 1984).

Other circumstances

The following practical circumstances must be considered:

- It should be possible to apply straw litter regardless of the type of pen. It is not recommended to apply

wood shavings and sawdust to calving pens

- Calving pens should be easy to access in case that any type of first aid is needed
- The placing of calving pens should facilitate optimum supervision
- It is not allowed to keep sick or injured cows in calving pens because of the danger of infection
- A wash basin and boot wash must be established close to the calving pen allowing people to wash hands and boots before entering the pen.

7.2 Literature

7.2.1 Sources

Blom, J.Y. & Jensen, A.M. 1996. Sundhed og sygdom hos kvæg.

Blom, J.Y., Thysen, I., Østergaard, V. & Møller, F. 1984. Kalvens sundhed og tilvækst i relation til staldklima, jern- og immunstatus samt sygdomsbehandling. 570. Beret. fra Statens Husdyrbrugsforsøg, 108 pp.

Broom, D.M. 1983. Cow-calf and sow-piglet behaviour in relation to colostrum ingestion. *Ann. Rech. Vet.* 14 (4), 342-348.

Edwards, S.A. 1982. Factors affecting the time to first suckling in dairy calves. *Anim. Prod.* 34: 339-346.

Edwards, S.A. & Broom, D.M. 1982. Behavioural interactions of dairy cows with their newborn calves and the effects of parity. *Anim. Behav.* 30: 525-535

Krohn, C.C. & Madsen, K. 1985. Undersøgelser vedrørende ko-kalv samspil. Medd. nr. 586 fra Statens Husdyrbrugsforsøg.

Krohn, C.C., Jonassen, B. & Munksgaard, L. 1990. Undersøgelser vedr. ko-kalv samspil. 678. Beret. fra Statens Husdyrbrugsforsøg.

Michanek, P. 1994. Transfer of Colostral Immunoglobulin to Newborn Dairy Calves. JBT Report 90, Lund.

Selman, I.E., McEwan, A.D. & Fisher, E.W. 1971a. Absorption of immune Lactoglobulin by Newborn Dairy Calves. *Res. Vet. Sci.* 12: 205-210.

Selman, I.E., McEwan, A.D. & Fisher, E.W. 1971b. Studies on Dairy Calves Allowed to Suckle their Dams at Fixed Times post partum. *Res. vet. Sci.* 12: 1-6.

Selman, I.E., McEwan, A.D. & Fisher, E.W. 1970. Studies on natural suckling in cattle during the first eight hours post partum II. Behavioural studies (calves). *Anim. Behav.* 18, 284-289.

Swanson, E.W. & Harris, J.D. 1958. Development of rumination in the young calf. *J. Dairy Sci.* 41: 1768-1776.

From cattle are born until they are six months old they are called calves. Male animals are from the age of six months until slaughter or until they are used for breeding purposes called bulls. Male animals used for breeding purposes are called breeding bulls. Female animals from the age of six months until they have calved the first time are called heifers. Young stock is a joint term for male and female cattle from the age of six months until slaughter or calving.

Some housing systems are more suitable for calves and others for young stock, while others may very well be used during the whole rearing period.

Calves may be housed separately or in joint pens including littered resting areas. Young stock may be housed in joint pens with littered resting area or in cubicles.

When calves stop drinking colostrum they should be placed in joint pens. Calves are only allowed to be housed separately until they are eight weeks

old. They should be able to see and hear other calves. Thus single pens must have open or partly open sides and the sides of the outdoor exercise folds of single calf huts must also be open, and they must be placed against each other. Calves are not allowed to be tied up permanently.

8.1 Single housed cattle

8.1.1 Single pen

Definition

Rectangular pens with room for one calf only and with a litter mat in the whole area, see figure 8.1. Milk and water should be supplied in a teat bucket or perhaps a calf bowl mounted outside the front gate. Concentrate is supplied in a bowl and hay in a hay-rack.

Recommendations

It is recommended to keep calves in single pens during the first week and perhaps until the age of eight weeks.

Dimensions

Table 8.1 lists single pen dimensions. In order to meet calves' need to move, pens should be dimensioned according to the recommended pen area.

Separation

The partition walls must be open or partly open. The distance between the vertical bars should be 8 – 10 centimetres. In order to ease the cleaning it is a good idea if the lowest 20 centimetres of the partition walls are solid.

Feeding rack

In order to prevent calves from putting their forelegs out of the feeding rack

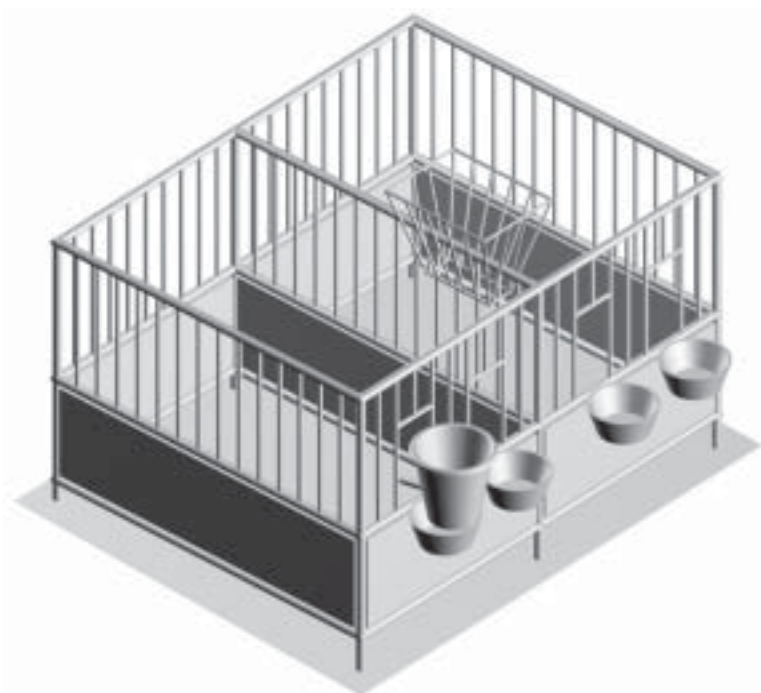

Figure 8.1.
Single pens for
calves.

Table 8.1. Dimensions of single pens for calves.

| Body weight, kg | Under 60 | Over 60 |
|--------------------------------------|----------|---------|
| Recommended pen area, m ² | 1.70 | 2.00 |
| Pen area, min., m ² | 1.20 | 1.40 |
| Pen length, min., m | 1.20 | 1.40 |
| Pen width, min., m | 1.00 | 1.00 |
| Pen side height, min., m | 1.00 | 1.10 |

Table 8.2. Feeding and drinking space dimensions in single pens.

| Body weight, kg | Under 60 | Over 60 |
|---|----------|---------|
| Feeding opening width, m | 0.19 | 0.20 |
| Feeding opening height, m | 0.28 | 0.30 |
| Min. volume of feed bowl, l | 6.0 | 6.0 |
| Feeding bowl upper edge height above floor, m | 0.45 | 0.50 |
| Bucket teat or dummy-teat height above floor, m | 0.70 | 0.80 |
| Hayrack bottom height above floor, max., m | 0.80 | 0.90 |

while they eat, the lowest part of the rack should be solid (all the way up to bowls/buckets). The feeding rack must be supplied with openings, through which the calf can put its head when it drinks and eats.

Floor

The pen floor should be designed to drain off urine. A solid floor that slopes towards a drainage channel, which is placed under the feed and drinking bowls, is recommended. A floor that is raised, compared to the feed alley, will facilitate supervision. A raised additional floor is not recommended, as it is difficult to maintain a satisfactory hygiene under the additional floor. Moreover, the ammonia evaporation increases and causes bad air in the housing. The pens should be well-littered.

Feed bowls, teat bucket and hayrack

Table 8.2 lists feeding and drinking space dimensions in connection with single pens. It is recommended to supply milk by means of teat bucket instead of bowl. A good hygiene is important regardless of the chosen milk supply means. Teat buckets should be demountable and easy to clean. A dummy-teat should be provided in those pens where milk is supplied by means of bowls. The feed bowls must be acid-proof and the sides of the bowl should be almost vertical. Moreover, it should be possible to demount bowls when they must be cleaned.

Water

Fresh drinking water should be supplied at least two times per day in teat buckets or bowls. Nipple drinkers are not recommended. If calves are housed in single pens more than one week after birth, a hayrack should be mounted above the dividing panel between two pens.

8.1.2 Calf huts

Definitions

Hut with deep litter and an outdoor exercise fold, see figure 8.2. Concentrate and hay are supplied inside the hut or in the exercise fold. Milk and water should be supplied by means of teat bucket or bowl placed in the exercise fold.

Recommendations

It is recommended to house calves that are less than 8 weeks old in calf huts with exercise folds. The exercise fold is necessary in order for the calves to be able to see and touch each other.

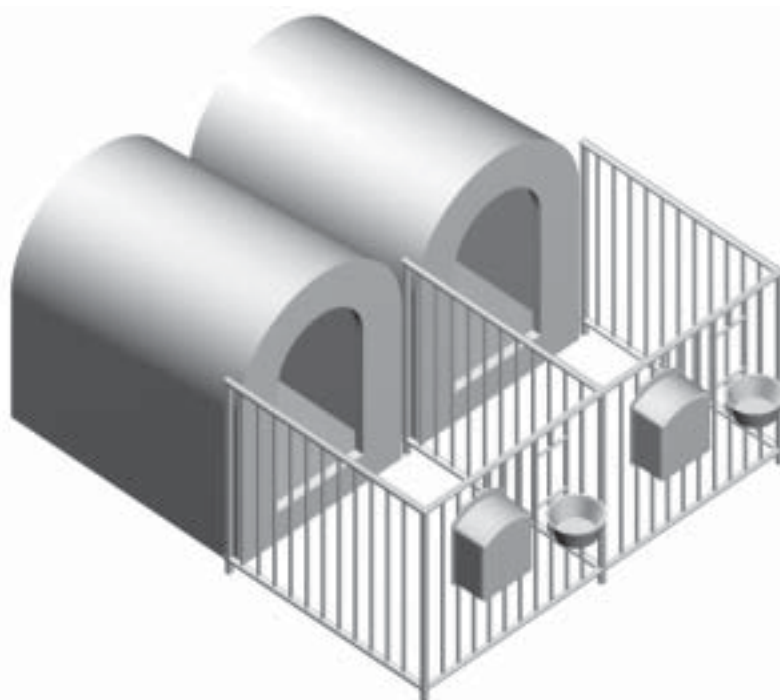

Figure 8.2.
Calf huts.

Chapter 8

Dimensions

Table 8.3. lists the hut and exercise fold minimum dimensions for one calf.

Separation / material

Calf huts should have a bright colour to avoid extremely high temperatures inside the hut during summer. Moreover, huts should be equipped with an adjustable ventilation vent. The sides of the exercise fold should be open, e.g. with vertical bars, allowing calves to see and touch each other.

Floor

Calf huts can be placed on a solid ground (e.g. concrete or asphalt), from which liquid is channelled to the storage tank for urine and liquid manure, or they may be placed on well-drained soil or grass. In the latter case the hut must be moved every second month. Finally, huts must be well-littered.

For further information about location, etc. of feed bowls, teat buckets and hayracks, please see section 8.1.1. Concentrate and hay must be protected from precipitation.

8.1.3 Stalls

Definitions

In stalls cattle are fixed by means of neck tether. The stall serves both as resting and feeding place, see figure 8.3. The stall floor is made of concrete or the like, and it slopes 2% to the rear. Litter is applied to the floor on the top

Table 8.3. Calf hut and exercise fold dimensions.

| Body weight, kg | Under 60 | Over 60 |
|----------------------------------|----------|---------|
| Hut | | |
| Recommended area, m ² | 1.70 | 2.00 |
| Area, min., m ² | 1.20 | 1.40 |
| Length, min., m | 1.20 | 1.40 |
| Width, min., m | 1.00 | 1.00 |
| Floor-to-ceiling height, min., m | 1.10 | 1.25 |
| Exercise fold | | |
| Area, min., m ² | 1.20 | 1.20 |
| Length, min., m | 1.20 | 1.20 |
| Width, min., m | 1.00 | 1.00 |
| Height, min., m | 1.10 | 1.10 |

of a mat/mattress or directly on the concrete floor. Feed is supplied in troughs in front of the stall and water in watering cups.

Recommendations

It is not recommended that young stock is housed permanently in stalls. It may be practical to tie up heifers for a short period, so they can get used to this kind of handling and tying.

Dimensions

Recommended stall length and width measurements for young stock are listed in table 8.4.

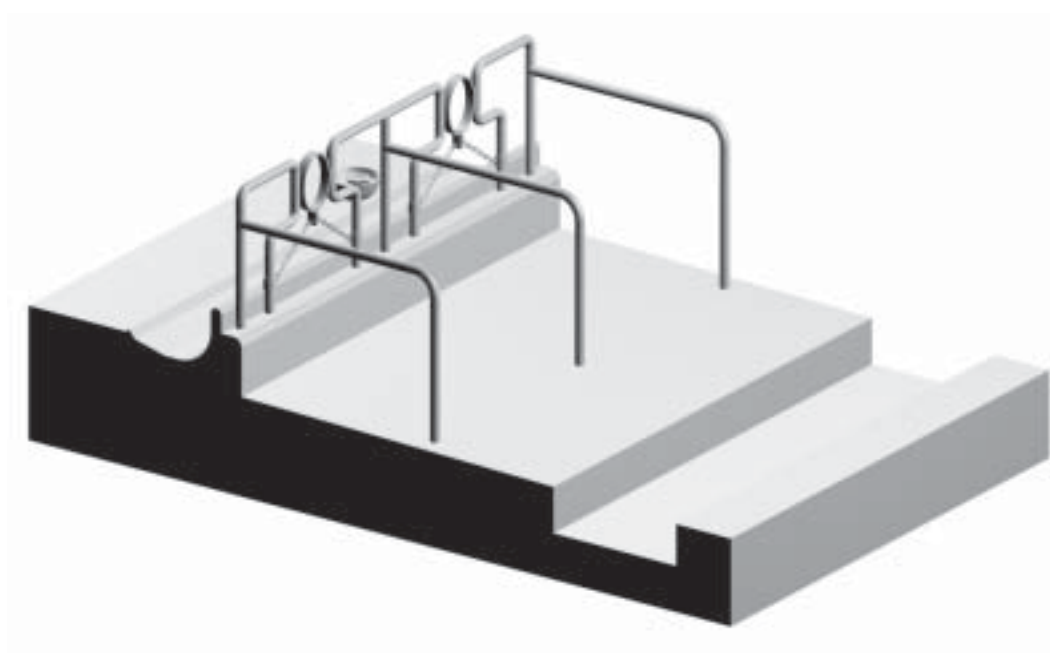

Figure 8.3.
Stalls for young stock.

Table 8.4. Dimensions of young stock stalls.

| Body weight from, kg | 100 | 150 | 200 | 300 | 400 | 500 |
|-----------------------|------|------|------|------|------|------|
| Stall width, min., m | 0.80 | 0.85 | 0.90 | 1.00 | 1.10 | 1.15 |
| Stall length, min., m | 1.25 | 1.30 | 1.40 | 1.55 | 1.70 | 1.75 |

Separation

There must be a partition between each animal in at least half of the stall length.

Tether

Tether should provide young stock with the greatest possible freedom to stand up or lie down naturally as well as carry out grooming. Sliding chain collar tying (see figure 9.28 in chapter 9) is most fitting.

Trough

It is most practical to design the trough with a front edge preventing young stock from pushing the feed out of reach. The width of the trough bottom should not exceed 40 – 60 centimetres dependent on the size of the animals. Moreover, the trough should be placed at least 5 centimetres, preferably 15 centimetres, above the stall floor. The rear edge of the trough should be at least 15 centimetres above the trough bottom, and the in-flexible part maximum 20 centimetres above the stall floor. This is why the upper part of the trough may favourably be made of a flexible material.

Floor

A solid floor with a soft bedding and litter should be applied in stalls. Stalls for bulls should provide a drain at the back of the stall through a grating or slatted floor. Steel gratings at the back of the stall floor are not to be recommended. The floor should slope at least 2% to the rear. Finally, stalls should be kept dry and they must be well-littered.

Drinking water

For information about drinking water allocation, watering cup design and location of cups, please see chapter 6, section 6.3.

8.2 Jointly housed cattle

Apart from the previous-mentioned exceptions, calves and young stock should

be housed in joint pens. The resting area of joint pens can be:

- A layer of litter, which is changed at least every third month
- Deep litter, which is renewed at intervals of more than three months
- Cubicles in which every animal has its own demarcated resting place

A distinction is made between the following two areas in connection with joint pens:

- Pen area = the total area which the animals have at their disposal in the pen
- Resting area = the total area with a bedding that is well suited for resting, flights/ramps exclusive.

Dimensions

The recommended dimensions of each pen type are listed in tables in the chapters concerned. The stated pen areas are necessary in order to meet the exercise needs of young stock, room required for avoidances, and to be able to establish sufficient individual distance. The listed minimum resting areas must be suited for resting, which means that e.g. ramps, flights and moist areas are not included in this dimension. If the animals have their own demarcated resting place like in cubicles, the resting areas may be smaller. See chapter 8, section 8.2.2. The recommended resting area dimensions for jointly housed young stock are based on experiments with up to 12 animals per pen.

Access conditions

The access conditions for each joint pen should be good. Thus man and animal should always be able to get safely and easily in and out of pens. Gates facing an inspection and drive alley is a good solution. Alternatively a gate facing the feed alley may be established, but the young stock should not have to pass any slippery troughs or trough edges.

Chapter 8

Table 8.5. Dimension of joint pens with a layer of litter or deep litter.

| Body weight from, kg | Under 60 | 60 | 100 | 150 | 200 | 300 | 400 | 500 |
|-------------------------------------|----------|-----|-----|-----|-----|-----|-----|-----|
| Pen area, min., m ² /dyr | 1.5 | 1.8 | 2.2 | 2.6 | 3.2 | 3.8 | 4.4 | 5.0 |
| Pen side height, min., m* | 1.1 | 1.2 | 1.3 | 1.3 | 1.3 | 1.3 | 1.3 | 1.3 |

* = Height is measured from the upper edge of the litter mat.

8.2.1 Joint pen with a layer of litter or deep litter

Definition

Joint pens in which a layer of litter or deep litter is at least provided in the resting area.

Floor

The floor must be able to stand loads of animals, tools and machines. Moreover, it should be impossible for moist to penetrate the floor and a suitable drain must be established.

8.2.1.1 Litter in the whole pen

Definition

Pens with a layer of litter or deep litter in the total pen area, see figure 8.4. The feed is administered in a raised feed alley or in a height-adjustable trough.

Recommendations

Pens with a layer of litter or deep litter in the whole area is to be recommended

for calves. From the age of four months calf hoofs must be trimmed as required due to lacking hoof wear.

Dimensions

If the whole pen is littered, the resting area is identical with the pen area, see the dimensions listed in table 8.5. For information about feeding area design, please see chapter 8, section 8.3.

8.2.1.2 Littered resting area and short non-littered feeding area

Definition

Pens with a layer of litter or deep litter in the resting area. Young stock stand on a short, raised feeding area and eat from the feed alley, see figure 8.5. There is unrestricted passage between resting and feeding area in full pen width. In case of a layer of litter in the resting area the animals have to climb one step to get to the feeding area, while flights with several steps are established in resting areas with deep litter.

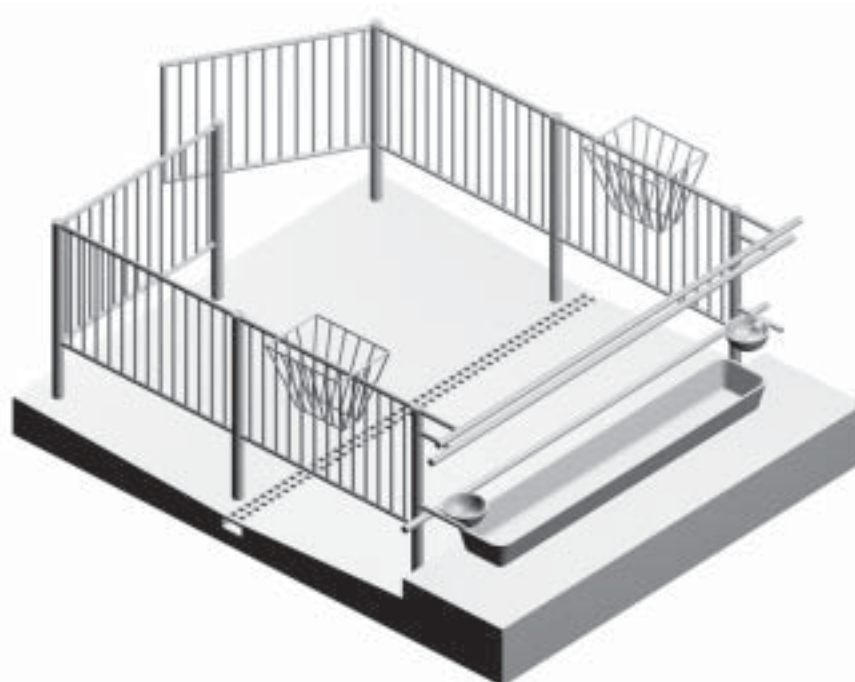

Figure 8.4.
Joint pen with a
layer of litter in the
whole pen.

Table 8.6. Dimensions of joint pens with short, non-littered feeding area.

| Body weight from, kg | Under 60 | 60 | 100 | 150 | 200 | 300 | 400 | 500 |
|---|----------|------|-------|-------------|-------|-------|------|------|
| Pen area, min., m ² /animal | 1.7 | 1.9 | 2.3 | 2.7 | 3.4 | 4.2 | 4.8 | 5.4 |
| Littered area, min., m ² /animal | 1.4 | 1.6 | 1.9 | 2.2 | 2.7 | 3.3 | 3.8 | 4.3 |
| Short feeding area length, min., m | 1.00 | 1.10 | 1.20 | 1.30 | 1.40 | 1.55 | 1.65 | 1.75 |
| Pen side height, min., m* | 1.1 | 1.2 | ————— | | 1.3 | ————— | | |
| Step width, m | ————— | | | 0.40 - 0.50 | ————— | | | |
| Step height, m | ————— | | | 0.15 - 0.20 | ————— | | | |
| Bottom step height, m** | ————— | | | 0.30 - 0.60 | ————— | | | |

* = Height is measured from the upper edge of the litter mat.
 ** = These measurements are at the same time the maximum difference in level between resting and feeding area in pens with a layer of litter.

Recommendations

Pens with littered resting area and short non-littered feeding area are recommended for calves and young stock. Moreover, littered resting area pens are only recommended for first calvers if deep litter is applied to the resting area, as it is the case with cows.

Dimensions

In table 8.6 the dimensions for joint pens with a short and non-littered feeding area are listed. For information about the feeding area layout, please see chapter 8, section 8.3.

8.2.1.3 Littered resting area and long non-littered feeding place

Definitions

Pens with a layer of litter or deep litter. Animals stand on a long raised feeding area and eat from a feed alley, see figure 8.6. Normally, passage from feeding area to resting area only takes place in a restricted part of the pen width, but it may also be totally open. If there is a layer of litter in the resting area, the animals have to climb one step to get to the feeding place, while they have to climb several steps in connection with deep litter.

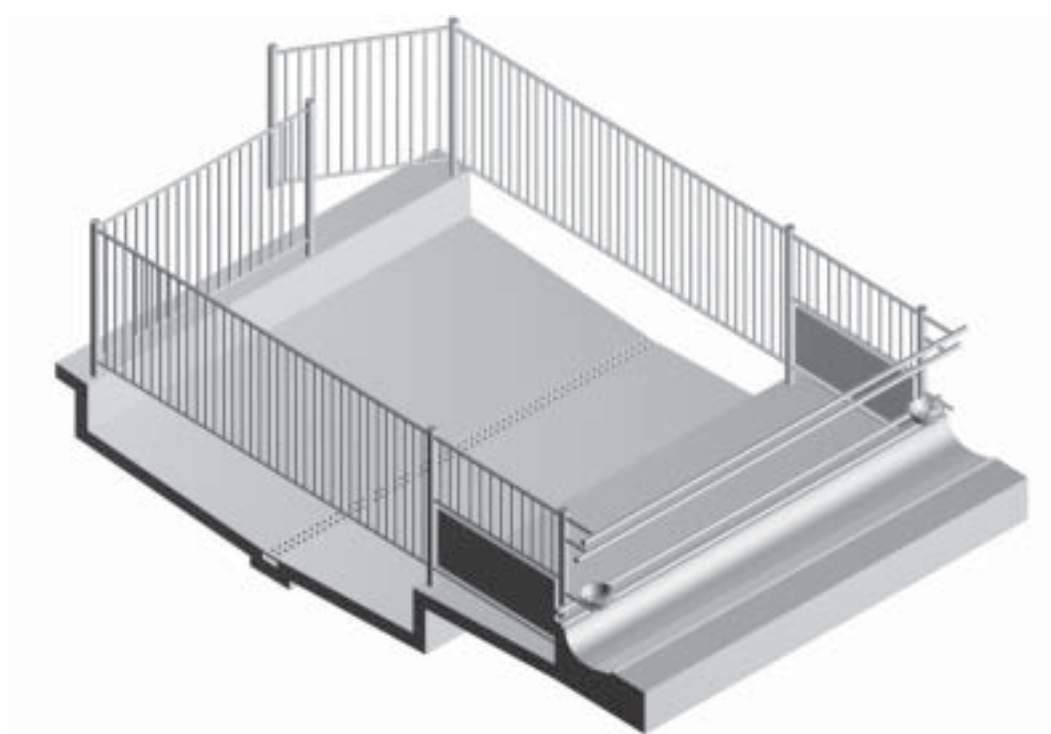

Figure 8.5. Joint pen with short non-littered feeding area and littered resting area.

Chapter 8

Table 8.7. Dimensions of joint pen with long, non-littered feeding area.

| Body weight from, kg | Under 60 | 60 | 100 | 150 | 200 | 300 | 400 | 500 |
|--|----------|-----|-------|-----------|-------|-----|-------|-----|
| Pen area, min., m ² /dyr | 1.7 | 1.9 | 2.4 | 2.9 | 3.7 | 4.4 | 5.2 | 5.6 |
| Littered area, min., m ² /dyr | 1.2 | 1.4 | 1.7 | 2.0 | 2.5 | 3.0 | 3.5 | 4.0 |
| Pen side height, min., m* | 1.1 | 1.2 | _____ | | | 1.3 | _____ | |
| Long feeding area length, min., m | 1.6 | 1.8 | 2.0 | 2.2 | 2.4 | 2.6 | 2.8 | 3.0 |
| Width of passage between resting and feeding area, min., m** | 1.2 | 1.3 | 1.4 | 1.5 | 1.6 | 1.7 | 1.8 | 1.8 |
| Step width, m | _____ | | | 0.40-0.50 | _____ | | | |
| Step height, m | _____ | | | 0.15-0.20 | _____ | | | |
| Bottom step height, m*** | _____ | | | 0.30-0.60 | _____ | | | |

* = Height is measured from the upper edge of the litter mat.

** = Applies to pens with up to 12 animals. More and wider passages are recommended in connection with larger pens.

*** = These measurements are at the same time the maximum difference in level between resting and feeding area in pens with a layer of litter.

Recommendations

Littered resting area and long non-littered feeding place is recommended for bulls and heifers that are more than six months old. It is only recommended for first calvers if deep litter is applied to the resting area, as it is the case with COWS.

Dimensions

In table 8.7 the dimensions for resting area, pen area and height of pen sides are listed. For information about feeding area layout, please see chapter 8, section 8.3.

8.2.1.4 Self-cleaning sloping pen

Definition

Pens where the resting area consists of a litter mat on a sloping floor. The activities of animals causes sliding of the litter mat onto a long feeding area from which the manure is scraped away.

Recommendations

Self-cleaning sloping pens are not recommended, as it is difficult to make the litter mat slide sufficiently and at the same time meet the resting area and litter application demands.

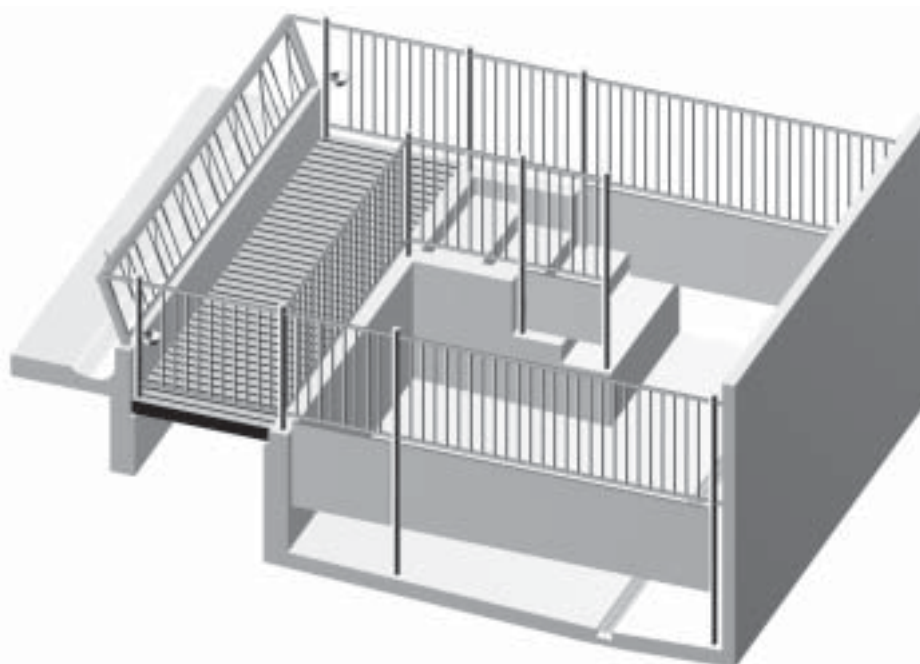

Figure 8.6. Joint pen with long, non-littered feeding area and deep litter in the resting area.

Table 8.8. Shelter dimensions.

| Body weight from, kg | Under 60 | 60 | 100 | 150 | 200 | 300 | 400 | 500 |
|---|----------|-----|-----|-----|-----|-----|-----|-----|
| Shelter area, min., m ² | 1.2 | 1.4 | 1.7 | 2.0 | 2.5 | 3.0 | 3.5 | 4.0 |
| Width of the shelter entrance, min., m* | 1.2 | 1.3 | 1.4 | 1.5 | 1.6 | 1.7 | 1.8 | 1.8 |

* = Applies to shelters with up to 15 animals. There should be more or wider entrances in larger shelters.

8.2.1.5 Joint hut with litter in the total area

Definition

A hut in which animals stay permanently, and with a layer of litter or deep litter in the total hut area, see figure 8.7. The feed is supplied in a trough which must be height-adjustable in connection with the deep litter.

Recommendations

Joint hut with litter in the total area is recommended for calves. From the age of four months the calves' hoofs must be trimmed as required due to lacking hoof wear.

Dimensions

If the whole hut is littered, the littered area is identical with the total hut area, see the dimensions in table 8.5 (joint pen with litter). For information about the feeding area layout, please see chapter 8, section 8.3.

Floor

Floor under well-functioning deep litter mats may be made of gravel used in road construction or the like.

8.2.1.6 Shelter with free access to outside area

Definitions

A detached perhaps mobile shelter with

a layer of litter or deep litter in the total area, see figure 8.8. Animals have unrestricted access to an outdoor exercise fold or grass field. The feed is supplied in an outdoor trough or the like.

Recommendations

Shelter is recommended for both calves and heifers. In winter conditions all animals must be able to lie down at the same time within the shelter.

Dimensions

Shelter dimensions are stated in table 8.8. For information about feeding area layout, please see chapter 8, section 8.3.



Figure 8.7. Joint pen for calves and young stock.



Figure 8.8. Shelter for calves and young stock.

Table 8.9. Dimensions of calves and young stock cubicles.

| Body weight from, kg | 100 | 150 | 200 | 300 | 400 | 500 |
|--|------------|------------|------------|------------|------------|------------|
| Width, minimum, m | 0.55 | 0.60 | 0.70 | 0.85 | 0.95 | 1.10 |
| Length (row against wall), min., m | 1.50 | 1.60 | 1.70 | 1.95 | 2.15 | 2.40 |
| Length (double rows) **, min., m | 1.40 | 1.50 | 1.60 | 1.80 | 2.00 | 2.25 |
| Bottom front rail, height above bedding: | | | | | | |
| - either min., m | 0.55 | 0.58 | 0.62 | 0.69 | 0.73 | 0.76 |
| - or max., m | 0.05 | 0.05 | 0.05 | 0.05 | 0.05 | 0.10 |
| Brisket board from rear kerb ***, +/- 0.05 m | 1.25 | 1.30 | 1.40 | 1.55 | 1.60 | 1.65 |
| Neck rail from rear kerb, +/-0.05 m | 1.20 | 1.25 | 1.35 | 1.50 | 1.55 | 1.60 |
| Neck rail height, +/- 0.05 m | 0.60 | 0.70 | 0.80 | 0.90 | 1.00 | 1.05 |
| Cubicle bedding downward slope, %, +/- 1% | 5 | | | | | |
| Cubicle bedding height above alley floor ****, m | 0.15-0.25 | | | | | |

- * = The width must be increased with 10% in cubicles with walled side partitions.
- ** = These measurements presuppose double rows without walled frontal partition that bothers the young animals when they are getting up and lying down naturally.
- *** = May be necessary if the flooring slopes down below 4% and/or to prevent young animals from lying down too close to the cubicle front.
- **** = These measurements state the bedding height above floor, inclusive mat or mattress, if any.

Floor

The floor under well-functioning deep litter mats may consist of gravel used in road construction or the like.

8.2.2 Cubicles

Definition

The resting area is a cubicle, the alley areas and the feeding area are provided with solid or slatted floor. Feed is supplied in the feed alley.

Recommendations

Cubicles are recommended for bulls and heifers that are more than half a year old. Cubicles are especially suitable for first calvers to be housed in cubicles or perhaps in tied-up housing like cows. The cubicle size must always correspond to the size of the individual animal and thus this housing system is less flexible.

The principles of cubicle design are shown in figure 9.1 to figure 9.6 inclusive in chapter 9.

Dimensions

Table 8.9 lists the recommended cubicle dimensions for calves and young stock.

Cubicle partitions

Cubicle partitions must end at least 0.20 metre from the rear kerb of the cubicle to prevent young stock, walking in the alley behind the cubicles, from getting injured. There must be a com-

pact partition wall/division plate at the end of each cubicle row next to the crossovers to protect young stock against draught and manure splashes. Moreover, in order to provide sufficient space, the width of the cubicles at the end of the row is increased with 10% compared to the other cubicles.

Rear kerb

The kerb between cubicle and alley must be so high (0.20 – 0.25 metres) that the young animal does not back into the cubicle. Furthermore, this height will force the animal to lie down and draw its tail onto the cubicle. Thus the young animal avoids pulling its tail into solid and liquid manure of the alley. It is not to be recommended to make the rear kerb higher than the bedding level.

Cubicle

Cubicles with mattresses/mats and straw mattresses must be littered daily with about 0.3 kg of straw to keep them clean and dry. Cut straw with a length of 3 – 5 centimetres may be applied with advantage. Sawdust and wood shavings are only recommended as litter, if these materials are without splinters and are made of oven-dried wood.

Cubicles with sand bedding must be flattened out every day and new sand must be supplemented regularly.

Table 8.10. Minimum alley widths stated in metre.

| Body weight from, kg | 100 | 150 | 200 | 300 | 400 | 500 |
|---|------|------|------|------|------|------|
| Feed alley – wall | 1.65 | 1.85 | 2.20 | 2.50 | 2.70 | 2.95 |
| Feed alley – cubicles a) one row | 1.65 | 1.85 | 2.20 | 2.50 | 2.70 | 2.95 |
| Feed alley – cubicles b) two rows | 2.00 | 2.20 | 2.60 | 2.95 | 3.25 | 3.25 |
| Feed alley – cubicles c) three rows or more/deep litter | 2.10 | 2.35 | 2.80 | 3.15 | 3.50 | 3.60 |
| Cubicles – cubicles | 1.10 | 1.20 | 1.30 | 1.50 | 1.90 | 2.20 |
| Cubicles – wall (free passage) | 1.10 | 1.20 | 1.30 | 1.50 | 1.90 | 2.20 |
| Crossovers | 1.00 | 1.00 | 1.00 | 1.15 | 1.45 | 1.65 |
| Crossovers with drinking places incl. water trough | 2.30 | 2.50 | 2.90 | 3.25 | 3.55 | 3.60 |
| Width of blind alleys, min. | 1.35 | 1.50 | 1.75 | 2.00 | 2.20 | 2.35 |

- a) a row of cubicles per feed alley side.
- b) two rows of cubicles per feed alley side.
- c) three or more rows of cubicles or deep litter per feed alley side.

Cubicles with sand or straw mat must be kept even with an onward slope. A slope down to the rear may prevent the animal from getting up naturally.

Alleys

All alleys must be slip resistant. Moreover, the alley floor may either be slatted or solid. The alleys and feeding area make up the exercise area, which is at the young animals' disposal. Alley dimensions are listed in table 8.10. The alley width serves the purpose of allowing animals so much room that they are able to pass each other and limiting their aggressions, collisions and abnormal behaviour. Alleys should not be blind. If blind alleys cannot be avoided, the dimensions in table 8.10 should be observed.

Figure 9.17 in chapter 9 shows principle sketches of four differently designed cubicle housing systems.

The number of cubicles in one farm section should be adapted to the size of the herd and calving intervals. It is extremely important that cubicle and young stock size go well together. This can be achieved by moving animals often. The maximum number of young stock per farm section should be 70 – 80 animals. A crossover should be established for every twenty cubicles in row.

As regards the height of partitions between farm sections, please see pen side height in table 8.5. For information about feeding area layout, please see chapter 8, section 8.3.

8.2.3 Joint pen with slatted floor

Definition

Joint pen with slatted floor in the whole pen area.

Recommendations

Joint pens with slatted floor are not recommended, as they cause problems in connection with animal welfare, behaviour, health and yield/production.

8.3 Feeding areas in joint pens

Definition

The feeding area consists of an area, which the animals can stand on during the feed intake, a feeding rack to separate animal and feed as well as a trough/feed alley from which the feed is supplied, see figure 8.9.

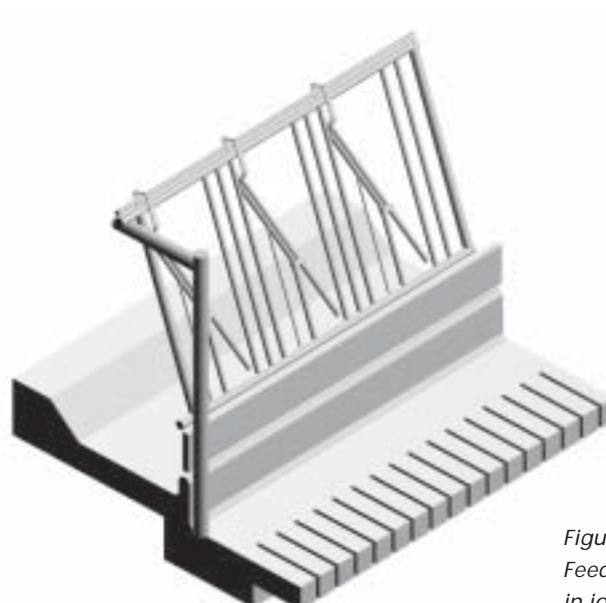

Figure 8.9. Feeding area in joint pens.

Table 8.11. Feeding area dimensions.

| Body weight from, kg | Under 60 | 60 | 100 | 150 | 200 | 300 | 400 | 500 |
|--|-----------------|-----------|------------|---------------|------------|------------|------------|------------|
| Trough rear edge, height above feeding area level, m | 0.4 | 0.4 | 0.45 | 0.45 | 0.5 | 0.5 | 0.55 | 0.55 |
| Feeding area width, +/- 0,05 m | 0.3 | 0.3 | 0.35 | 0.4 | 0.5 | 0.55 | 0.6 | 0.65 |
| Height above feeding level of trough bottom, min., m | ————— | | | | 0.15 | ————— | | |
| Trough width, max., m | 0.4 | 0.4 | 0.45 | 0.5 | 0.55 | 0.55 | 0.6 | 0.6 |
| Width of acid-proof trough surface, min., m | 0.5 | 0.55 | 0.6 | 0.65 | 0.7 | 0.75 | 0.8 | 0.85 |
| Feeding rack upper rail above feeding area, min. m | ————— 1.1 ——— | | 1.2 | ————— 1.3 ——— | | 1.4 | | |
| Trough cubic content, min., l | 15 | 15 | 20 | 25 | 30 | 35 | 40 | 40 |
| Feeding landing height, max., m | ————— | | | | 0.10 | ————— | | |
| Feeding landing width, min., m | ————— | | | | 0.40 | ————— | | |

8.3.1 Roughage and concentrate Recommendations

In connection with restricted feeding one feeding place is recommended per animal or automatic feeder to supply the rationed feedstuff. In connection with ad lib feeding a maximum of 3 animals is recommended per feeding place. Four to five bulls may share one concentrate feeder.

Dimensions

The layout of the feeding area must allow animals to reach the feed, when assuming their natural feeding position, without having to press hard against the equipment. Moreover, the layout should prevent injuries. The feeding area dimensions are stated in table 8.11.

Feeding area floor

A slip resistant feeding area floor made of concrete or the like is an advantage for young stock, as they can get used to a hard surface and experience hoof wear. In connection with short feeding area solid floor sloped to the littered area is recommended. As regards long feeding areas slatted or solid floor sloped towards the liquid manure drain is recommended. 0.5 metre of the slatted floor that leads directly to the feed alley may be solid and slope towards the slatted floor.

Feeding rack

The feeding rack should facilitate access of young stock to the feed and at the same time separate animal and feed enough to prevent dirty feed and feed loss. The lowest part of the feeding rack is a solid trough rear edge. A height-adjustable neck rail above this may be the simplest way to separate animal and feed. The neck rail must be placed in an angle of 20° above the trough measured vertically from the top side of the trough rear edge. Feeding rack gates with self-locking feed barriers must also be placed in an angle of 20°. Feeding rack gates will provide animals with less opportunities of disturbing each other than neck rails. However, there is a higher risk that animals get stuck in connection with feeding rack gates. Feeding rack gates must be designed to open the self-locking feed barriers at the bottom if an animal falls and gets its head stuck in the head gate.

Trough

The trough should be equipped with a front edge to prevent young stock from pushing the feed out of reach. Pens with deep littered feeding area should apply height-adjustable troughs. Young stock must always stand lower than the trough bottom while they eat.

Straw feed must be supplied in troughs or hayracks (see table 8.2).

8.3.2 Milk feeding

Milk should mainly be supplied by means of an artificial teat, either in the form of a teat bucket (see chapter 8, section 8.1.1) or automatic milk feeders.

Recommendations

It is recommended to mount teat-dummies in the calf housing. Teat-dummies provide calves with the opportunity of having their sucking need met.

Automatic milk feeder

An automatic milk feeder consists of a device, which mixes milk powder and water, and a drinking station that protects calves while they are suckling milk from the artificial teat.

The capacity of the milk feeder as well as the feeding strategy will determine the number of calves, which the feeder is able to serve. One feeder may be able to operate several drinking stations. Normally, one drinking station will be able to serve about 20 calves.



The drinking stations must be designed in a way that calves will not get hurt and at the same time they should be build to protect calves from other calves while they drink. The drinking station design (height and width) must be adapted to those calves that are going to drink from it. Thus calves will be able to assume normal drinking positions while they are suckling milk.

The drinking station must be placed near feed and water to keep the resting area quiet.

The drinking station should be placed in a way that calves are led to its entrance naturally, e.g. parallel to the sides of the pen. When locating the drinking station it is important not to create blind corners in which low-ranging calves may be driven by dominating calves. Figure 8.10 and 8.11 depict the drinking station design principles, which will protect calves.

8.3.3 Drinking water

For information about drinking water allocation, watering cup and water trough designs as well as their location, please see chapter 6, section 6.3.

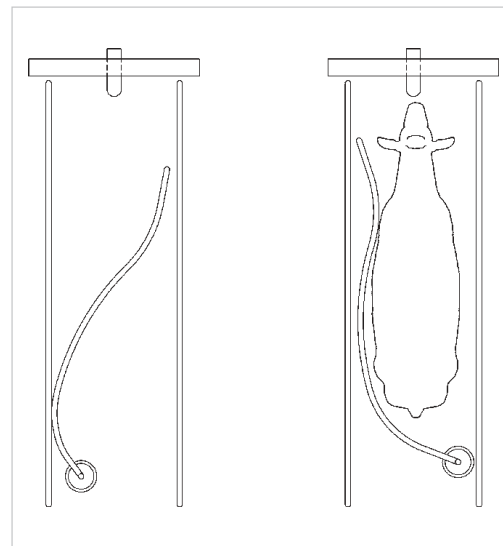

Figure 8.10.
(Left)
Example of drinking station of an automatic milk feeder.

Figure 8.11.
(Right)
Sketch of drinking station, which protects the drinking calf from other calves.

Chapter 8

Background and motivation

Behaviour

- Calves should have access to a dry resting place which is free from draught (small calves lie down 16 – 18 hours per 24 hours)
- Calves should be able to lie with stretched forelegs and the head resting on the bedding or flat on one side with stretched legs. These lying positions are assumed 15 – 20% of the lying time (Putten and Elshof, 1982)
- Calves have a great urge to suck during the first months. If calves are fed from bucket/bowl the unmet need to suck is directed at equipment and neighbouring calves (Mees and Metz, 1984). Teat buckets and automatic milk feeders are reasonably good cow teat substitutions (Gjestang, 1981; de Wilt, 1985; Sambraus, 1980)
- Calves must be supplied with fresh water every day (Bogner, 1982)
- Solid food at an early age will stimulate the ruminant function (Swanson & Harris, 1954)
- From the age of three to four weeks the calf's need for social contact increases (Lidfors, 1987; Sambraus, 1980)
- A lack of social contact during the period when calves are fed milk will make calves fear each other later on when they are housed jointly (Veissier et al., 1994; Jensen et al., 1999)
- If calves are not able to lick each other for social purposes, they may lick themselves excessively and they risk developing hair balls in the rumen (Broom, 1982)
- Animals reared individually (in tied-up housing or single pens) will only to a small extent be motivated by the activity of other animals and their performance of social behaviour is drastically limited (Bogner & Reising-Berner, 1982)
- After a couple of days calves that are housed restrictively will feel a rising need to move around (Jensen, 2000). An unsatisfied need to move may result in sudden and violent ac-

Calf and young stock cubicle and alley dimensions recommended in the literature.

Calf and young stock cubicle dimensions, Dutch recommendations

| Weight, kg | Width, m | Length, m |
|------------|-------------|---|
| 100 | 0.60 | 1.30 |
| 150 | 0.67 | 1.52 |
| 200 | 0.73 | 1.65 |
| 300 | 0.80 | 1.84 |
| 400 | 0.88 | Against wall: 1.98 Against cubicle: 1.90 |
| 500 | 1.00 - 1.10 | Against wall: 2.20 Against cubicle: 2.10 |

Source: Anonym, 1999.

Calf and young stock cubicle dimensions, American recommendations

| Weight, kg | Width, m | Length, m |
|------------|----------|-------------|
| 150 | 0.75 | 1.55 |
| 200 | 0.75 | 1.55 |
| 300 | 0.95 | 1.70 - 1.85 |
| 400 | 1.07 | 1.98 |
| 500 | 1.07 | 1.98 |

Source: Anonym, 1997.

Alley width dimensions, Dutch recommendations

| Weight, kg | 100 | 150 | 200 | 300 | 400 | 500 |
|---------------------------------|------|------|------|------|------|------|
| Feeding alley, m | 1.75 | 1.95 | 2.05 | 2.20 | 2.45 | 2.75 |
| Alley between 2 cubicle rows, m | - | - | - | 1.75 | 1.95 | 2.00 |

Source: Anonym, 1999.

tivities and subsequent injuries (Neuschütz, 1982)

- Young stock is in need of early social experiences. Heifers, which are housed together from an early age, are more tolerant to each other than if the group is established late (Bouissou and Hövels, 1976)
- Getting up and lying down behaviour, normal resting positions and grooming behaviour are to a large extent influenced by tether design and pen dimensions (Bogner, 1982)
- Young stock always prefer soft bedding (Irps, 1987)
- Many behavioural activities are reduced on smooth and hard bedding and flooring. Thus abnormal behaviour often arises, especially, in connection with the lying-down behaviour (Andreae and Smidt, 1982; Irps, 1984)
- A high animal density in joint pens will cause unrest in the shape of aggressiveness and an increased number of violent activities which forces animals to get up and mount each other, heifers as young bulls. This unrest may reduce the lying time considerably (Jensen, 1992)
- It is complicated for young stock to lie down on slatted floor. The number of interruptions of the lying down and getting up behaviours is increased, and these activities are often carried out abnormally. The behavioural changes partly develop because it is difficult for animals to lie down on a smooth and hard bedding, and partly because of physical injuries, as this abnormal behaviour may be an attempt to spare sore joints (Jensen, 1992)
- Access to a littered bedding will improve the welfare of young stock (Sørensen and Krohn, 1999)
- The weight gain among large heifers will increase at the expense of small heifers in case of a diverse herd composition with restricted concentrate allocation. If the heifer size differs considerably, the risk that small heifers will be seriously injured increases (Sørensen and Krohn, 1999)
- The feeding time decreases and the level of aggression increases concurrently with a rising number of animals per feeding area at the feed alley (Beneke, 1985)

- The frequency of abnormal behaviour and unrest when young stock mount each other increases concurrently with a rising animal density (Beneke, 1985)
- The frequency of abnormal behaviour is larger among young bulls in tied-up housing than bulls housed in pens with slatted floor or deep litter (Andersen et al., 1991)
- Often abnormal oral behaviour occurs if the roughage lacks structure (Graf, 1985)

Health

- First of all calf housing must be dry, clean and free from draught (Blom et al., 1984; Webster et al., 1985; Østergaard et al., 1986; Hansen, 1988). The most common calf diseases are pneumonia, diarrhoea and arthritis. However, pneumonia occurs most frequently (Blom et al., 1984). It seems to be less important whether calves are able to touch each other or not, because the potential infection may be everywhere in the housing air. A good health is achieved among calves housed in calf huts (Hansen, 1985) or in calf houses divided into sections (Østergaard et al., 1986)
- Normally, the number of health problems among calves from half a year to two years is very low. Almost all diseases and physical injuries are due to the immediate environment. Young stock thrive in totally open and uninsulated housing
- A hard bedding which lacks litter can cause pain in joints and hoofs (Reiland et al., 1978)
- Hoof health is worse in connection with slatted floor pens than tied-up housing (Andersen et al., 1991)
- Tail treads solely occurs on non-littered bedding (slatted floor/- concrete) and the frequency rises concurrently with a rising animal density (Konggaard et al., 1984; Madsen et al., 1987)
- The risk of skidding in connection with social behaviour, grooming and mounting is higher on slatted floor than on deep litter (Ming, 1984)
- The frequency of hoof and leg problems is high in connection with a hard bedding (slatted floor/concrete).

Chapter 8

Other conditions

The layout of calf pens must make allowance for the following practical conditions:

- It should be easy to remove manure either manually or by means of front/mini loader
- It should be possible to apply straw litter to all pen types
- It should be possible to turn off the water supply
- There should always be a couple of single pens for sick calves in joint pen housing systems
- Heat lamps should be available to sick calves in uninsulated housing systems
- Calves for slaughter and rearing should be separated from each other, because calves for slaughter must gain as much weight as possible, while large breed rearing heifers are not allowed to gain more than 600 grams per day (Jersey heifers should not gain more than 450 grams) (Foldager and Sejrsen, 1991)
- Feed troughs must be capacious (minimum 15 litre per calf) and the design must consider the anatomy of calves and minimise feed loss.
- In connection with restricted feeding there should always be one feeding place per animal to make sure that low-ranking animals get enough feed
- Trough separations that prevent animals from touching each other while they are fed, will result in fairly uniform feed intake
- It should be possible to fix young bulls by means of self-locking feed barriers in joint pens.

8.4 Literature

8.4.1 Sources

Andersen, H.R., C.C Krohn, J. Foldager, L. Munksgaard, & S. Klasttrup. 1991. Opstaldningens og fodringens indflydelse på ungtirens adfærd, produktion og råvarekvalitet. 700. Beretn. Statens Husdyrbrugsforsøg. 39 pp.

Andreae, U. & D. Smidt. 1982. Behavioural alterations in young cattle on slatted floors. In Bessei, W. (Ed) Disturbed behaviour in farm animals. Hohenheimer Arbeiten, Heft 121. EEC-seminar.

Anonym. 1997. Dairy Freestall Housing and equipment. 6. udg. MWPS-7. Iowa State University, Ames, Iowa. 136 pp. ISBN 0-89373-078-4.

Anonym. 1999. Huisvesting jongvee en melkvee. Red.: Ina Vink, Albert Pieters. Praktijkonderzoek Rundvee, Schapen en Paarden (PR). Lelystad. Holland.

Beneke, B. 1985. Zum Flächenbedarf zuchtfähiger Färsen in Rinderlaufställen. Aus den Institut für Tierzucht und Tierverhalten, Mariensee, der Bundesforschungsanstalt für Landwirtschaft Braunschweig-Völken (FAL) Institutsteil Trenthorst-Wulmenau.

Blom, J.Y., I. Thysen, V. Østergaard, & F. Møller. 1984. Kalvens sundhed og tilvækst i relation til staldklima, jern- og immunstatus samt sygdomsbehandling. 570. Beretn. Statens Husdyrbrugsforsøg. 108 pp.

Bogner, H. 1982. Several minimum requirements, from the standpoint of animal protection, for housing and fattening of calves. In Signoret, J.P. (Ed.), Welfare and husbandry of calves. Martinus Nijhoff. CEC-seminar. 107-113.

Bogner, H. & F. Reissing-Berner. 1982. Verhalten von Mastkälbern in verschiedenen Haltungssystemen. Tierärztl. Prax. 10, 465-470.

Bouissou, M.F. & J. Hövels. 1976. Effet d'un contact précoce sur quelques aspects du comportement social des bovins domestiques. *Biology of Behaviour* 1:17-36.

Broom, D.M., 1982. Husbandry methods leading to inadequate social and material behaviour in cattle. In Bessei, W. (Ed) Disturbed behaviour in farm animals. Hohenheimer Arbeiten, Heft 121. EEC-seminar. 30:42.

Foldager, J. og K. Sejrsen. 1991. Opdrætningsintensitetens indflydelse på den senere mælkeproduktion hos RDM- og SDM-kvier. 693. Beretning fra Statens Husdyrbrugsforsøg. 131 pp.

Gjestang, K.E. 1981. Omgivelser for kyr og kalver. Sluttrapport nr. 375.

Graf, B. 1985. Verhaltens Anomalien im Funktionskreis Fussverhalten bei intensiv gehaltenen Mastbullen. In 4 GFT-Seminar angewandte Nutztierethologie Bayerischen Landeanstalt für Tierzucht, Grub BRD. 10 pp.

Hansen, K. 1985. Kalveytter. SJF Orientering nr. 31. Statens Jordbrugstekniske Forsøg. 22 pp.

Hansen, K. 1988. Enkeltbokse eller fællesbokse til nyfødte kalve. SJF Orientering nr. 60. Statens Jordbrugstekniske Forsøg. 19 pp.

Irps, H. 1984. Result of research project into flooring preferences of cattle. In Baxter, S.H., M.R. Baxter & J.A.C.. MacCormack. (Ed.) Farm animal housing and welfare. Nijhoff Publishers, Boston. 200 – 215.

Jensen, M. B. 1992. Opstaldning af kvier og ungtire. Adfærd, sundhed, stressfysiologiske reaktioner, reproduktion og produktion. Litteraturreview. Landskontoret for Kvæg. 82 pp.

Jensen, M.B., L. Munksgaard, L. Mogensen. & C.C. Krohn. 1999. Effects of housing in different social environments on open-field and social responses of female dairy calves. *Acta Agriculturae Scandinavica, Sect. A, Animal Science*, 49:113-120.

Jensen, M.B. 2000. A note on the effect of isolation during testing and length of previous confinement on locomotor behaviour during open-field test in dairy calves. *Applied Animal Behaviour Science* (in press).

Konggaard, S.P., J.G. Larsson, E.B. Madsen, & K. Nielsen. 1984. Haletråd hos ungtire. I En epidemiologisk undersøgelse. 558. Medd. Statens Husdyrbrugsforsøg.

Lidfors, L. 1987. Moder-unge beteende hos nötkreatur i semi-naturlig miljø – en orienterende studie. Rapport 17. Sveriges Lantbruksuniversitet.

Madsen, E. B., I. Thysen, K.L. Ingvarsen & V. Østergaard. 1987. Ungtires sundhed og produktion ved forskellig belægning i spaltegulvsbokse. I . Østergaard, V. & J. Hindhede (Ed.). Studier i kvægproduktionssystemer. 628. Beretn. Statens Husdyrbrugsforsøg. 209-219.

Mees, A.M.F. & J.H.M. Metz. 1984. Sugverhalten von Kälbern – Bedürfnis und Befriedigung bei verschiedenen Tränkesystemen. *KTBL-Schrift* 299:82-83.

Chapter 8

- Ming, J. 1984. Untersuchung über die Eignung von Lochund Spaltenboden (Beton-flächenroste) in der Rindviehmast. Diplomarbeit, ETH, Zürich, Switzerland.
- Neuschütz, N. 1982. Verhaltensbiologische Untersuchungen in der Rinderproduktion unter besonderer Berücksichtigung haltungsbedingter Verhaltensanomalien. Arch. Tierzucht. 25:229-242.
- Putten, G. van & W.K. Elshof. 1982. Inharmonious behaviour of veal-calves. In Bessei, W. (Ed) Disturbed behaviour in farm animals. Hohenheimer Arbeiten, Heft 121. EEC-seminar.
- Reiland, S., B. Strömberg, S.E. Olsson, I. Dreimanis & I.G. Olsson. 1978. Osteochondrosis in growing bulls. Pathology, frequency and severity on different feedings. Acta Radiol. Suppl. 358:1790-1796.
- Sambras, H.H. 1980. Humane considerations in calf rearing. Anim. Regul. Stud. 3:19-22.
- Swanson, E.W. & J.D. Harris. 1958. Development of rumination in the young calf. Journal of Dairy Science, 41:1768-1776.
- Sørensen, J.T. & C.C. Krohn. 1999. Opstaldningens indflydelse på opdrættets adfærd, sundhed og produktion. Rapport nr. 9. Danmarks Jordbrugs-Forskning. 63 pp.
- Veissier, I., V. Gesmier, P.L. Neindre, J.Y. Gautier & G. Bertrand. 1994. The effects of rearing in individual crates on subsequent social behaviour of veal calves. Applied Animal Behaviour Science. 41:199-210.
- Weber, R. 1999. The effect of a gated feeding stall on the cross-suckling of calves housed in grouped pens. In: Institut für Landtechnik der TU München-Weihenstephan (editor), Tagung: Bau, Technik und Umwelt 1999 in der landwirtschaftlichen Nutztierhaltung. 231-236.
- Webster, A.J.F., C. Saville, B.M. Church, A. Gnana-sakthy & R. Moss. 1985. The effect of different rearing systems of the development of calf behaviour. Br. Vet. J. 141:249-264.
- Wierenga, H.K. 1987. Behavioural problems in fattening bulls. In Schlichting, M:C: & D. Smidt (Ed.). Welfare aspects of housing systems for veal calves and fattening bulls. CEC-seminar. Mariensee.
- Wilt, J.G. de., 1985. Behaviour and welfare of veal calves in relation to husbandry systems. Thesis. Agricultural University. Wageningen.
- Østergaard, V., J.Y. Blom, I. Thysen, K. Hansen & K.O. Birkkjær. 1986. Kalvesundhed, tilvækst og økonomi ved sektionering af kalvestalden. 610. Beretn. Statens Husdyrbrugsforsøg, 67 pp.
- ### 8.4.2 Supplementary literature
- Blom J.Y., H. Kromann, M. Steffensen & A.M. Kjeldsen. 1999. Fælleshytter til slagte-kalve. Rapport nr. 85. Landskontoret for kvæg. Landbrugets Rådgivningscenter. 31 pp.
- Hansen, K. 1984. Klimaforsøg med kalve, Isolering – Ventilering – Varme. Beretn. nr. 21. Statens Jordbrugstekniske Forsøg. 35 pp.
- Hansen, K. 1987. Opstaldning af kalve. Lukkede, uisolerede stalde – Åbne uisolerede stalde – Kalvehytter. Beretn. nr. 34. Statens Jordbrugstekniske Forsøg. 35 pp.
- Hansen, K. & H. Kromann. 1993. Ungkvægstalder med dybstrøelse eller strøelseslag. SJF Orientering nr. 80. Statens Jordbrugstekniske Forsøg. 32 pp.
- Hansen K. 1995. Undersøgelse af bokse med trædeudmugning til ungvæg. Forskningsrapport nr. 40. Statens Husdyrbrugsforsøg. Afd. For Jordbrugsteknik og Produktionssystemer. 20 pp.
- Hansen K. 1996. Dybstrøelse til kvier. Opsamling af al gødning i strøelsesmåtten. Forskningsrapport nr. 52. Statens Husdyrbrugsforsøg. Afd. For Jordbrugsteknik og Produktionssystemer. 36 pp.
- Hansen K. & H. Kromann. 1996. Skal kvier kunne gå ud om vinteren? Erfaringer fra praksis, indsamlet ved interviewundersøgelse. Produktudvikling af staldsystemer til kvæg. Rapport 96.02. Landbrugets Rådgivningscenter og Statens Husdyrbrugsforsøg. 16 pp.
- Hindhede, J. & M.B. Jensen. 1995. Kvier kvitterer for bedre plads i boksen. Bovilogisk Tidsskrift 5-95. 24-26.
- Jensen M.B., 2000. Kalves behov for bevægelse. JordbrugsForskning nr. 2, 2000. Danmarks JordbrugsForskning. 12-14.
- Justitsministeriet. 1993. Bekendtgørelse om beskyttelse af kalve. Nr. 999, 14. december 1993.
- Justitsministeriet. 1997. Bekendtgørelse om ændring af Bekendtgørelse om beskyttelse af kalve. Nr. 1075, 22. december 1997.
- Jørgensen, J. C., S. Eriksen, O. Kristensen, K. Hansen, P. Keller & H.B. Rom. 1990. Stalde med trædeudmugning, SJF Orientering nr. 70. Statens Jordbrugstekniske Forsøg. 16 pp.
- Kromann, H. 1993. Løsdriftstalder til ungvæg. Idékatalog og eksempler fra praksis. Landbrugets Rådgivningscenter. 75 pp.

Milking cows are kept in two completely different housing systems: Either in joint or individual housing.

The term joint housing covers the following housing types:

- Cubicle
- Feeding cubicle
- Deep litter
- Self-cleaning sloping pen.

The term individual housing covers the following housing types:

- Tied-up
- Catch-stall.

9.1 Loose housing – joint housing

Definition

This is a housing system in which the cows can move around freely. The housing types; cubicle, feeding cubicle, deep litter and self-cleaning sloping pen are typically divided according to function into a resting, feeding, and milking area.

9.1.1. Housing types – divided into type of resting area

9.1.1.1 Cubicles

Definition

The resting area is divided into cubicles that function as resting place for each individual cow. The cubicles are separated by partitions to protect the cow and consider its need for individual distance. The bedding comfort is ensured by applying loose bedding material, e.g. straw, sand and the like or a bed of synthetic materials.

Thus cubicles must be a demarcated, comfortable and sheltered resting place. Moreover, the design of cubicles should provide a clean, dry and deformable bedding as well as make sure that it is easy for the cow to lie down and get up again.

Recommendations

Cubicles can be recommended. There must be one cubicle per cow.

9.1.1.2 Feeding cubicles

Definition

Feeding cubicles function both as a feeding and resting area for each individual cow. The pens are separated by partitions in order to protect the cow and consider its need for individual distance.

Recommendations

Feeding cubicles cannot be recommended because:

- Cows move forward in the pen and defecate on the bedding
- A low frequency of cow traffic on the slatted-floor walking areas will result in dirty alleys
- Cows drag more manure into the cubicles
- The low front edge results in a large feed loss in the cubicle
- Relatively short pens involve the risk of pressure injury
- There are no escape routes for low ranking cows
(Rådum et al., 1982; Hansson and Wahlander, 1991)

9.1.1.3 Deep litter

Definition

The resting area is undivided and the bedding consists of a deep litter mat.

Recommendations

Deep litter resting area and separate feeding area with slatted/solid floor can be recommended.

Deep litter without separate feeding area (deep litter in the whole housing area and mobile feed boxes/racks) cannot be recommended because:

- Deep litter in the whole area will not bring about the normal hoof wear of animals
- The cows are not accustomed to walking surfaces
- It involves a high risk of hoof sufferings
- It involves a relatively large litter utilisation
- The deep litter mat is worn down around the feed boxes/racks.

9.1.1.4 Self-cleaning sloping pen

Definition

The resting area consists of a (recycled) manure mat at a floor that slopes down towards the feeding/cleaning area. The cow traffic will make the manure mat slide onto the feeding area from which the manure can be scraped away.

Recommendations

Self-cleaning sloping pens are not to be recommended because:

- A high density rate is required to obtain an appropriate sliding of the manure mat
- The passage between the feeding and resting area will often be highly worn down and this will result in dirty cows
- The amount of litter must be carefully adjusted to the number of cows on the mat. Too much litter will prevent the mat from sliding and too little will lead to a very worn down and dirty mat
- This system is very onerous as regards maintenance of the manure mat, as it is recommended to litter twice or several times daily. (Jørgensen et al. 1990).

9.1.2 Resting area

9.1.2.1 Cubicles

Definition

A separate bedding in which the individual cow is protected by a partition.

Cubicles consist of a resting area and an unobstructed opening towards the front of the cubicle for the cow to thrust its head through (get-up-zone) when it rises and lies down. The room requirements and dimensions of cubicles are stated in table 9.1.

Recommendations

Separation

Partition and bottom front rails:

Cows must be able to rise and recline freely in one continuous movement without obstacles and without being injured when they get into contact with the partition or the bottom front rail. This is especially important when cows lie down, as the last part of the lie down movement is uncontrollable.

Cubicle partitions that are hung up are often fastened to two horizontal front rails. To prevent the bottom front rail from bothering the cow it may either be mounted low (maximum 10 centimetres above the level of the bedding) (see figure 9.1) or high (minimum 80 centimetres below the level of the bedding) (see figure 9.2). Partitions that are cast in and attached with bolts can be mounted without the bottom horizontal front rail. This is also the case with partitions that are hung up if a post is being applied for each partition.

The cubicle partition must end minimum 0.30 metres from the rear kerb of

Table 9.1. Room requirements and dimensions of cubicles.

| | Jersey | Large breed |
|---|-----------------------|-------------|
| Width*, min., m | 1.10 | 1.20 |
| Total length (rows towards wall), min., m | 2.40 | 2.60 |
| Total length (double rows)**, min., m | 2.25 | 2.45 |
| Bottom front rail, height above bedding: | | |
| - eiteher, min., m | 0.70 | 0.80 |
| - or, max., m | 0.10 | 0.10 |
| Brisket board from rear kerb ***, +/- 0.05 m | 1.65 | 1.75 |
| Neck rail from rear kerb, +/-0.05 m | 1.60 | 1.70 |
| Neck rail height, +/- 0.05 m | 1.05 | 1.10 |
| Cubicle slope, %, +/- 1% | 5 | 5 |
| Bedding height above cow alley floor **** | ————— 0.20-0.25 ————— | |
| * = The width of cubicles against closed side partitions must be increased with 10% | | |
| ** = Implies two rows against each other without disturbing partitions. | | |
| *** = May be necessary if the bedding slope is below 4%. | | |
| **** = States bedding height above floor including matt and mattress, if any. | | |

Chapter 9

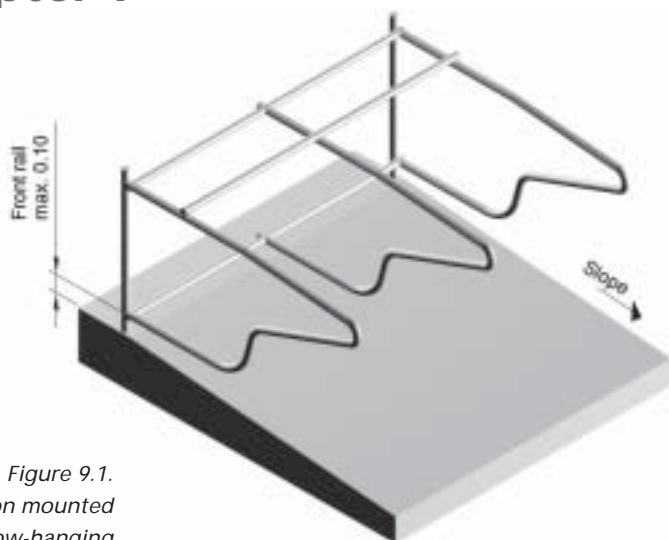

Figure 9.1.
Partition mounted
on low-hanging
front rail.

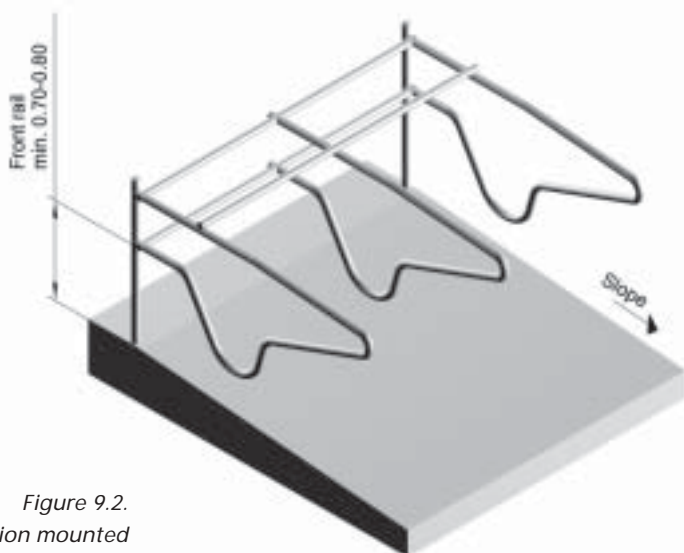

Figure 9.2.
Partition mounted
on high-hanging
front rail.

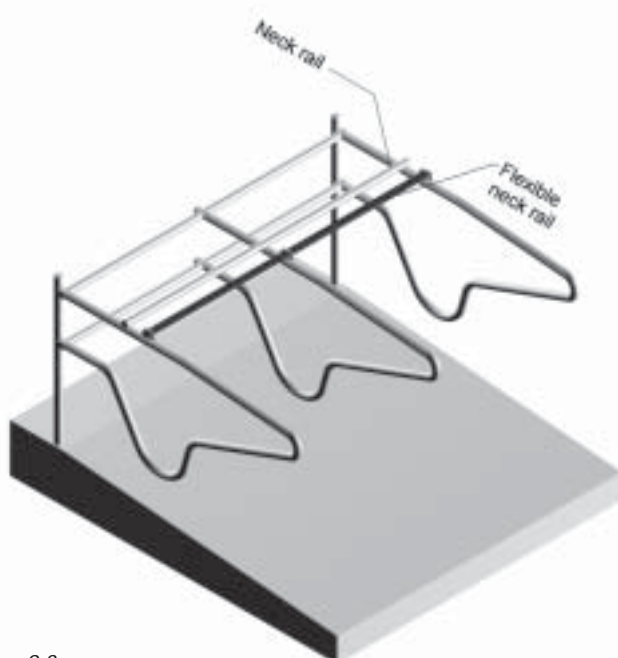

Figure 9.3.
Flexible neck rail.

the cubicle to avoid that cows, which walk on the alley behind the cubicles, are injured. There must be a compact partition wall/division plate at the end of each cubicle row next to the cross-overs to protect cows against draught and manure splashes. In order to provide sufficient wall space, the width of the cubicles at the end of the rows is increased with 10% compared to the other cubicles.

Neck rail

The neck rail must ensure that the cubicle is kept clean. If the neck rail is adjusted correctly, the cow will move back one step when it rises. In this way solid and liquid manure are avoided on the bedding.

In order to make it easier for cows to adjust to using the cubicles when taking in to use a new housing system, the neck rail must during the first 14 days be placed 15 centimetres further in the front than usually. It should be possible to adjust the neck rail from time to time and thus a system is required which makes it easy to move the neck rail.

The neck rail is often an iron pipe, however, it may also consist of a flexible material. A flexible neck rail is less restrictive, but functions the same way as the inflexible rail. (See figure 9.3).

Brisket board

A brisket board is recommended in cubicles with no or only a slight downward slope (below 4%) so that cows will not move too much forward in the cubicle and have difficulties at rising (see figure 9.4).

The brisket board may e.g. be a rounded off wooden plank. There are also several other kinds of prefabricated brisket boards, which are sold as part of the housing system equipment. The brisket board may either be mounted on the partition or the floor. The prefabricated board is usually of plastic or metal.

A raised concrete platform ("pillow") is not recommended.

Rear kerb

A high rear kerb will prevent solid and liquid manure from splashing on the cubicle bedding. The kerb between cubicle and cow alley must be so high (0.20 – 0.25 metres) that the cow does not back

into the cubicle. Furthermore, this height will force the cow to recline and draw its tail onto the cubicle. Thus the cow avoids pulling its tail into the solid and liquid manure of the alley. It is not to be recommended to make the rear kerb higher than the bedding level.

Cubicle bedding

The cubicle bedding must be of a dry, slip resistant material that can be deformed.

The total length of the cubicle base in cubicles with synthetic mats or mattresses should at least slope 5% to the rear. (See figure 9.5).

A rear kerb/plank 0.25 – 0.30 metres above the cow alley must be established in cubicles with loose bedding material such as straw mats, sand or the like. Thus the cubicle floor can be established on the same level as the alley and without slope. (See figure 9.6).

Cubicles with synthetic mattresses/mats and straw mats must be littered daily with at least 0.5 kg straw. Cut straw with a length of 3 – 5 centimetres may be applied with advantage. Sawdust and wood shavings are only recommended as litter, if these materials are without splinters and are made of oven-dried wood. It is recommended to use the same amount as straw.

Cubicles with sand bedding must be flattened out every day and new sand must be supplemented, as occasion requires. The sand utilisation on Danish farms varies from 1 – 10 kg sand per cow/day.

Cubicles with sand or straw mat must be kept even with a slope towards the rear kerb.

Background and motivation

The cubicle is partly used as resting and standing area in which the cow is protected from other cows.

Behaviour

The resting behaviour of cattle kept in cubicles is primarily influenced by the following factors:

- Cubicle number
- Cubicle bedding
- Cubicle litter
- Cubicle location in the cow house
- Cubicle delimitation
(Wierenga et al., 1989).

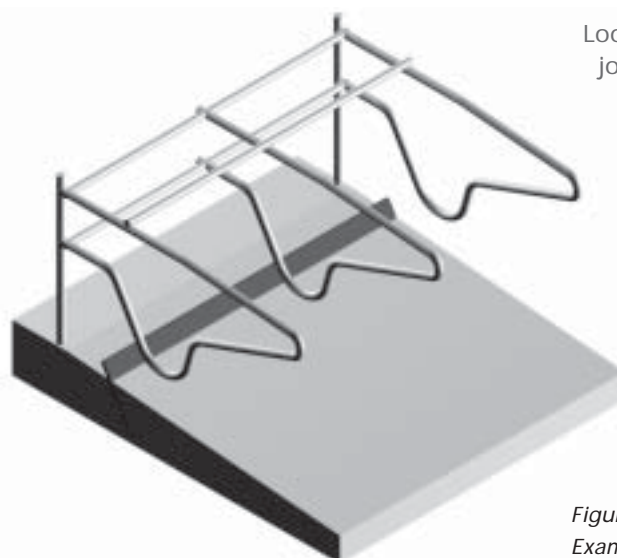

Figure 9.4.
Example of bricket
board design

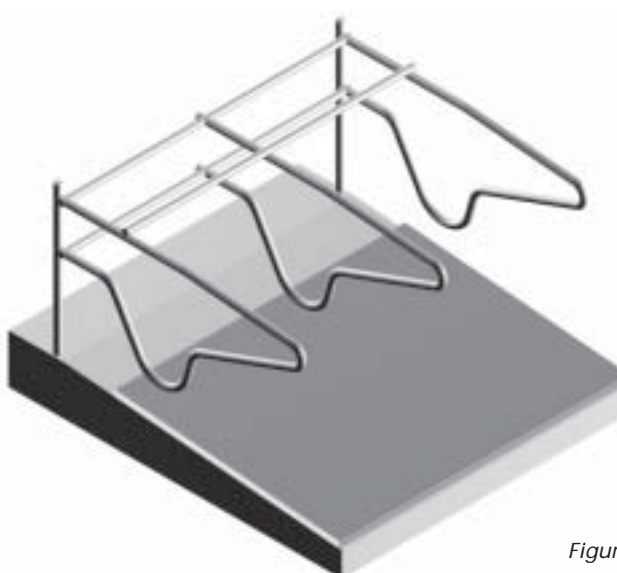

Figure 9.5.
Cubicle with syn-
thetic mattress.

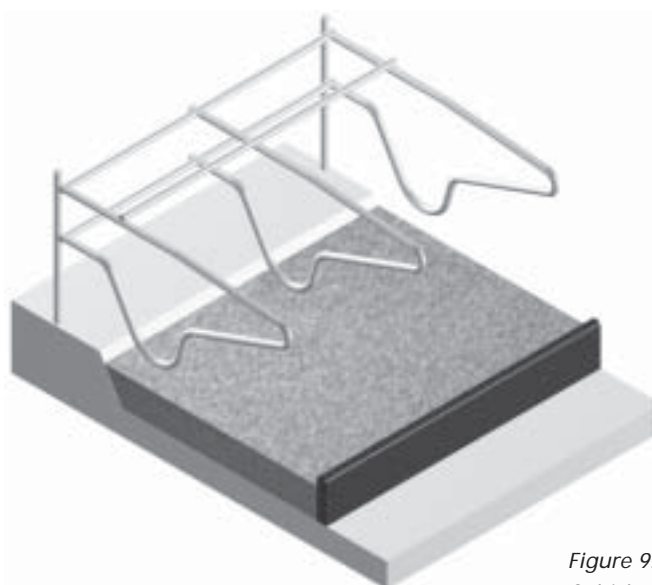

Figure 9.6.
Cubicle with loose
bedding material

Chapter 9

Cows have a great need to lie down. Thus this behaviour has a high priority among cows. All cattle should be able to lie down at any time (however, not in the milking area and in the holding area) (Metz, 1984; Metz & Wierenga, 1984).

The aggression level and the frequency of abnormal behaviour will rise if there is more than one cow per cubicle (Henneberg et al., 1986; Metz, 1981; Metz and Mekking, 1984; Wienrenga, 1983).

Cows prefer soft to hard bedding. (Colam-Ainsworth et al., 1989; Gebremedhin et al., 1985; Jensen et al., 1988; Natzke et al., 1982; Irps 1983).

Cows prefer soft and heat insulated mats to hard rubber mats (Natzke et al., 1982; Maton & Daelemans, 1989).

Concrete beddings and beddings of hard mats are not satisfactory unless they are littered with a thick layer of straw (Hansen et al., 1999).

It is recommended that the slip resistant coefficient should be at least 0.5 (this corresponds to a dry concrete slab) (Hansen et al., 1999).

Cubicles must be so big that cattle can easily rise and lie down without any hindrances. Cubicles must be so narrow that cattle do not lie across them. Moreover, cubicles must be so narrow that the solid and liquid manure are dropped outside the cubicle and so long that straw is kept away from alleys with manure (Irish and Martin, 1983).

Too short cubicles is the main reason for cubicle refusal or rising difficulties (Cermak, 1987).

The lying down time increases when the cubicle width increases from 1.05 to 1.20 metres. Likewise, the lying time increases when the cubicle length increases from 2.10 to 2.50 metres (Cermak, 1987).

Cubicles in which the slope to the rear is too small (2%) will make cows move forward. Thus a brisket board must be applied as a stopping device (Christensen, 1998).

Cubicles in which the downward slope is appropriate (4%) will have the effect

The literature recommends the following total measurements for cow cubicles

Single row

| Weight, kg | Width, m | Length, m |
|--------------------------------|----------|-----------|
| 575 | 1.20 | 2.41 |
| 625 | 1.20 | 2.45 |
| 725 | 1.20 | 2.53 |
| <i>(Cermak, 1987)</i> | | |
| 545 | 1.14 | 2.33 |
| 635 | 1.22 | 2.43 |
| 725 | 1.22 | 2.54 |
| <i>(Irish og Martin, 1983)</i> | | |
| 550 | 1.12 | 2.31 |
| 650 | 1.15 | 2.35 |
| 750 | 1.18 | 2.46 |
| <i>(CIGR, 1994)</i> | | |

that cows, when they rest and move around in the cubicle, will neither skid forward or backwards in the cubicle (Christensen, 1998).

The end cubicles of each row, cubicles near open doors, under ventilation plants (air injection unit) as well as cubicles in which the walking alley behind the cubicles is highly used, e.g. near water troughs and feed alleys, are less attractive resting areas (Wierenga and Hopster, 1989; Potter and Broom, 1987; Irish and Martin, 1983).

The partition between the cubicles must be high enough to prevent cows from turning around. Moreover, partitions must be so long that cows can neither stand or walk across cubicles and so short that they do not obstruct cows walking on the alleys behind the cubicles (Irish and Martin, 1983).

Partitions both in front and between cubicles must not prevent cows from rising and lying down (Wierenga and Hopster, 1989).

Mats and mattresses

If the knee of a cow is able to sink 30 millimetres into the bedding layer, the load will be reduced to less than one third of the load on a concrete base (Hansen et al., 1999).

At 2,000 Newton any bedding material should at least be pressed down 16 and

not more than 28 millimetre. If the material is pressed down more than 28 millimetre, the pressure of the knee is reduced very slowly, and thus a softer material does not improve the softness of the lying comfort substantially. (Hansen et al., 1999).

The remaining depression of hard rubber mats is little. However, the remaining depression of soft rubber mats is also acceptable, if the bedding slopes minimum 5%. A considerable layer of litter will, normally, prevent liquid from collecting in the bedding in connection with two-layer mattresses, provided that the slope towards the rear kerb is sufficient. On the other hand, it may be difficult to keep beddings with mattresses that are channel sewn dry at the rear end of the cubicle (Hansen et al., 1999).

The surface of the beddings must be so soft that the cow's knee sinks at least 16 millimetres into the bedding when it lies down and rises (Hansen et al., 1999).

Normally, heat insulation of beddings is considered by means of softer beddings (Hansen et al., 1999).

The bedding layer must be so elastic that the remaining depression does not exceed 5 millimetres (Hansen et al., 1999).

The slip resistant coefficient of the bedding layer should be at least 0.5, which corresponds to a dry concrete slab (Hansen et al., 1999).

The surface of the bedding material should not be so rough that the cows suffer hair losses or other injuries (Hansen et al., 1999).

Health

It is assumed that a hard cubicle floor (concrete or slatted floor) loads cows (Andreae and Smidt, 1982) and increases the risk of injuries owing to pressure (Blom et al., 1983).

Generally, cows kept on straw litter contract fewer diseases than cows kept on alternative littering (Smidt et al., 1985).

A daily litter amount of 600 kilogrammes per cow is better than 300 kilogrammes. A frequent supply and piling of the same total straw supply in layers

will improve the health of cows (Smidt et al., 1985).

The application of rubber mats in cubicles and an increased amount of litter reduces the number of injuries (Blom, 1981).

A high (>0.15 metre) and sharp-edged brisket board will increase the number of knee injuries (Blom, 1982).

Partitions must be without any sharp edges, as they are very likely to cause injuries owing to pressure on the cow bodies (Blom, 1981).

9.1.2.2 Resting area with deep litter and separate feeding area

The height of manure mats that are removed twice a year: 1.6 metre (approx. 8 m³/cow).

The distance from the resting to the feeding area should be as short as possible to reduce the loading of the deep litter mat and at the same time reduce conflicts between walking cows and cows that are lying down. A rectangular area with a minimum width of 6 metres is preferred. The deep litter area must not form part of the holding area and cows should not walk directly from the milking parlour to the deep litter area. Space requirements and dimensions of deep litter areas are listed in table 9.2.

In figure 9.7, 9.8 and 9.9 different deep litter housing constructions are shown.

Flights and ramps

Often the resting and the feeding area are not at the same level (split-level) and thus the two different levels are connected by flights or ramps. Experiments have shown that especially cows prefer flights to ramps. The steps of flights must be so broad that cattle can easily see them. If the steps are too narrow cattle will not dare to step out far enough on the step and they risk tearing of the dew claws on the edge of the steps. In other cases cattle step out too far on the steps and risk stumbling and falling down the stairs.

The slope of cattle ramps should not exceed 17% (Hansen and Keller, 1991). Moreover, slip resistant flights and ramps must be applied and rails/banisters must be provided on the sides.

Table 9.2. Space requirements and dimensions of deep litter areas.

| Resting area | Jersey | Large breed |
|---|---------------|--------------------|
| Littered resting area per cow, min., m ² | 5.0 * | 6.5 * |
| Total area per cow, m ² | 7.0 | 8.5 |
| Width of entrance to deep litter, min., m/cow** | 0.20 | 0.20 |
| Flights | | |
| Step width, approx. m | 0.50 | 0.60 |
| Step height, approx. m | 0.20 | 0.20 |
| Height of lowest step, approx. m | 0.60 | 0.60 |
| * = Corresponds with 1 m ² /100 kg. | | |
| ** = No staircase should be less than 1,80 m. | | |

Separation

If cows are divided in groups, it should be possible to divide the resting area crosswise by means of partitions. Each group must have access to the feeding area.

The partition height must be adjustable. Moreover, it should be easy to get past the partition when littering the resting area. Finally, partitions should be easy to remove, when the manure mat is removed.

If the resting and feeding areas are parallel and if the level of the resting area is below the feeding area level, partitions must be placed between these two areas. Additionally, it should be possible to bar the crossover (rank or flights) that connects the two areas.

Litter

Straw litter can be applied. Litter should be sprinkled in such a way that the resting area is always dry and clean.

The amount of litter remains the same irrespective of the straw sort. The litter must be dry.

Background and motivation

Behaviour

It is supposed that the animal density rate will affect the level of aggression, as this is the case in other housing types (Henneberg et al., 1986; Wierenga, 1983).

The lie-down and get-up behaviours are normal in connection with deep litter housing (Andrae and Smidt, 1982).

Cows prefer soft to hard bedding (Jensen et al., 1988; Natzke et al., 1982; Irps, 1983).

Cows tend to lie down longer on deep litter than on a solid bedding with litter (Smidt et al., 1985).

Other circumstances

The straw quality is essential to an efficient manure mat (Hansen, 1993).

If the alley that leads to the resting area is narrow, there is an increased risk that the manure mat will wear down (Hansen, 1993).

The application of sawdust is only recommended, if this material is without splinters and made of oven-dried wood (Anonym, 1994).

The deep litter area should not be used as a passage to and from the milking parlour or as holding area (Hansen, 1993).

A litter material of poor quality and a moist manure mat will lead to a poor udder health in connection with deep litter housing systems (Hansen, 1993).

Moreover, a litter material of poor quality will cause a rise in the litter utilisation of at least 1.5 kg per cow/day (Hansen, 1993).

Large amounts of beet in the feed will also cause a rise in the litter utilisation of 1.5 kg. per 10 kg of beet (Hansen, 1993).

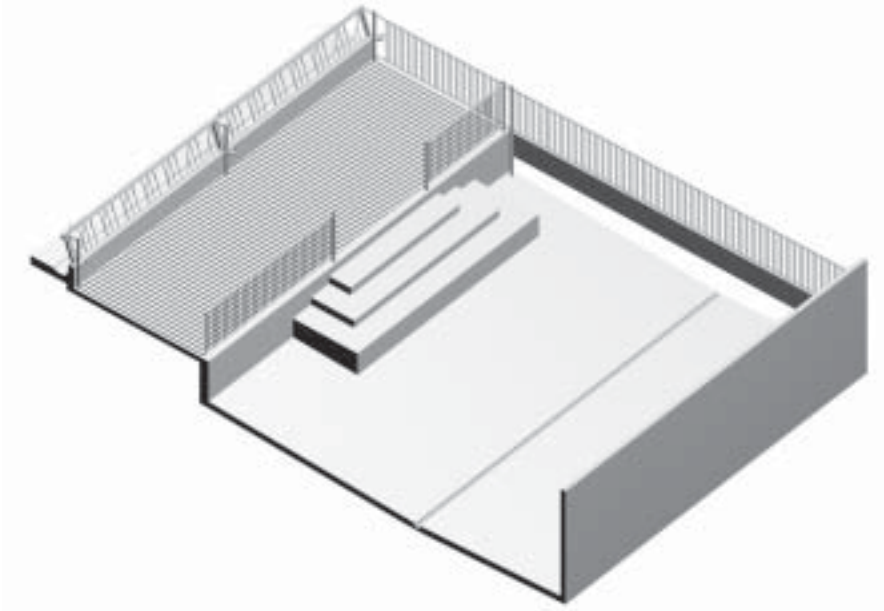

Figure 9.7.
Deep litter housing
with resting area
below feeding area
level.

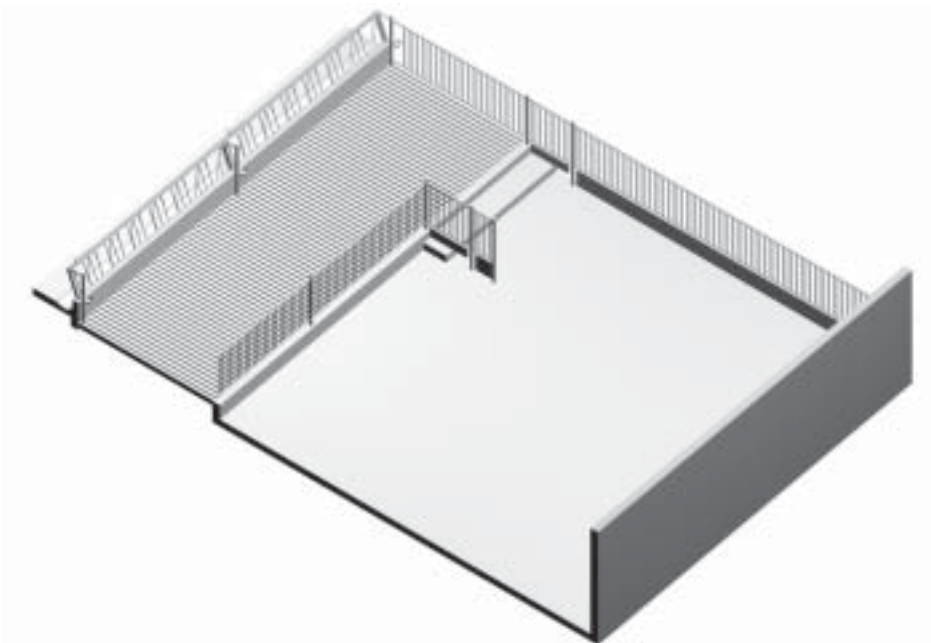

Figure 9.8.
Deep litter housing
with resting area
partly below feed-
ing area level.

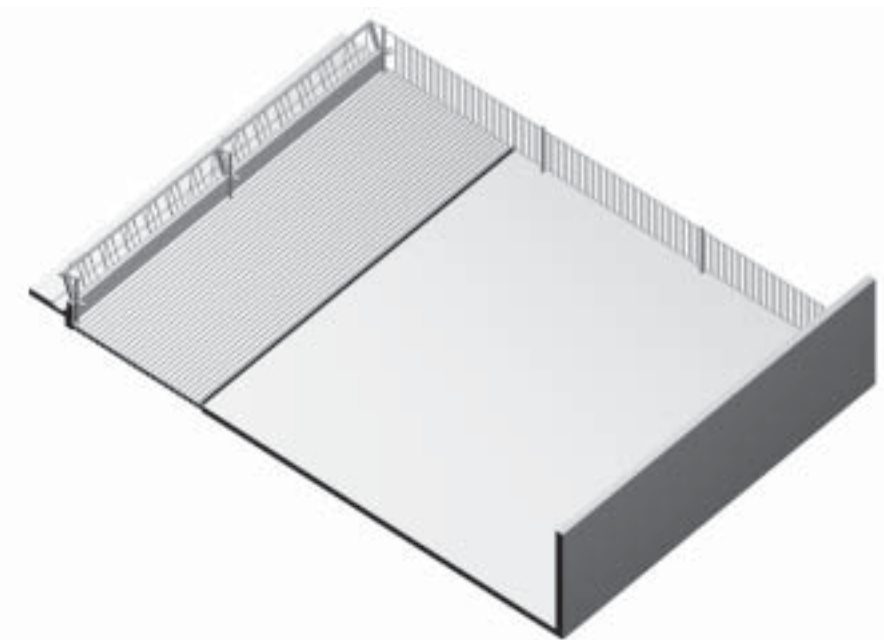

Figure 9.9.
Deep litter housing
with resting area
on a level with feeding
area level.

Chapter 9

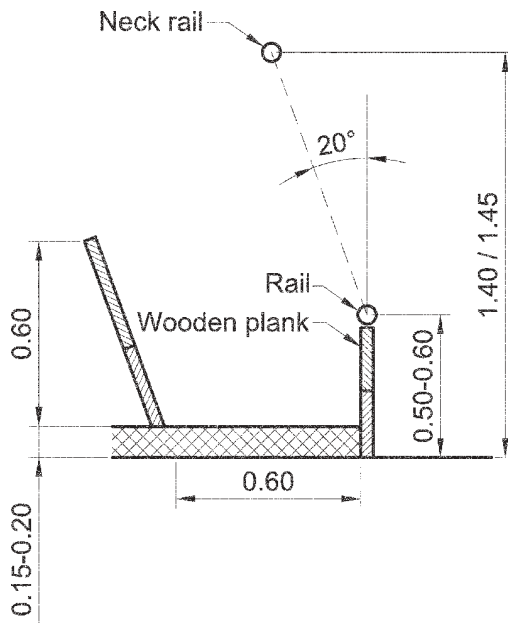

Figure 9.10. Feeding area design (principle construction in loose housing system).

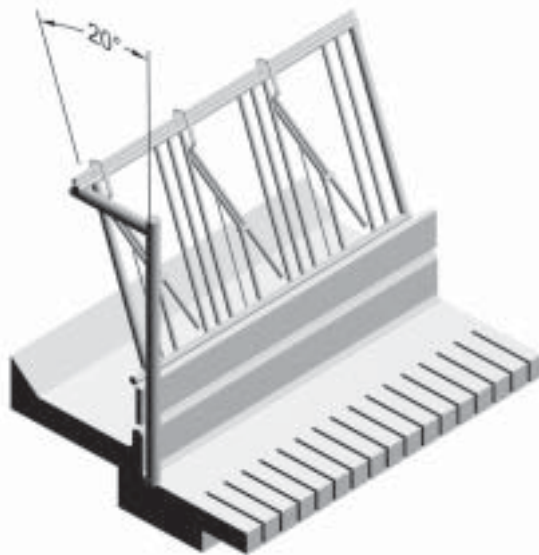

Figure 9.11. Design of feeding rack with self-locking feed barrier.

9.1.3 Feeding area

In a loose housing system cows normally feed from a joint feed alley or from feed boxes/racks. Moreover, concentrate, grain and beets can be distributed by means of automatic feeding stations.

Recommendations

Trough design

The trough should be created with an edge, so that cows cannot push the feed out of reach. See table 9.3. for trough dimensions and space requirements. (See figure 9.10, 9.11 and 9.12).

Room requirements and dimensions

Number of cows per feeding place:

Max. 1 in connection with restrictive feeding
Max. 3 in connection with ad-lib feeding*

*In connection with ad-lib feeding complete feed/single feedstuff units is supplied according to appetite, and feed must be available in the feed alley 20 – 22 hours per day and night.

In case of restrictive feeding, the complete feed or single feed stuff is distributed once or several times per day and night. Moreover, the cow may be feed an individually apportioned feed supplement. Finally, there must be space enough for all the cows to be at the trough at the same time in case of restricted feeding. In connection with loose housing systems and, especially, farms that do not divide cattle permanently into groups, a temporary clutching/fixing of cattle during the first part of the feeding is required. Thus it is

Table 9.3. Feeding place space requirements and dimensions.

| Feeding place, space requirement | Metre |
|--|-------------|
| Trough rear edge, height above feeding place/area level* | 0.50 - 0.60 |
| Feeding place width per cow (Large breed/Jersey) +/- 0.05 m | 0.70 / 0.65 |
| Trough bottom height above feeding area level | 0.15 - 0.20 |
| Trough width, max. | 0.60 |
| Width of acid-proof trough surface, min. | 0.90 |
| Feeding rack top rail above feeding place (Large breed/Jersey), min. | 1.45 / 1.40 |

*Rear edge should be made of tight material up to the bottom rail of the feeding rack.

possible for weak cattle and first calvers to eat their feed ration without being disturbed by higher-ranking cows.

In case of restricted feeding the farmer must provide space for two or three extra cows than each group does actually make up, in order for the “last” cow to be able to find room at the trough.

If an individually apportioned amount of feed supplement is provided for each cow, cows should be fixed for short periods during the feeding to prevent them from stealing feed from each other. If concentrate is supplied by means of automatic feeding stations, the farmer should choose a type that distributes concentrate at a variable speed. Normally, cows can eat about 300 kilogrammes feed pellets per minute.

In case of ad-lib feeding, feed must be provided in the trough day and night, and a maximum of three cows are allowed per feeding place. If a restricted number of feeding places are applied, it can be recommended to mount partitions between the feeding places. If the cows are fed ad-lib, there must be plenty of space at the feeding place and alleys that facilitate the cow traffic between the resting and feeding areas.

Restricted feeding places should not be applied, if only a few animals are prevented from having access to the feeding area. This situation may actually cause more stress among cows than situations where there are two or more animals per feeding place. The number of cows that cannot have access to the feeding place, at first, must account for such a large part of the herd (at least 15 animals) that the flock rhythm is upset.

Feeding rack

(Separation device between feeding area and feed alleys)

It is recommended that the feeding rack slopes about 20 degrees towards the trough. An appropriate width of the feeding rack neck openings is 0.17 metre for Jersey cows and 0.19 metre for large-breed cows. There are not allowed any other openings of the equipment that are wider than 0.15 metre. (See figure 9.13).

The self-locking feed barriers must be easy to open, if a cow falls while it is caught.

Water troughs should never be placed in the middle of a section with self-locking feed barriers, but rather at the end of the sections.

There should be plenty of manholes or easily-operated gates. Boot wash for the cleaning of footwear should be established in connection with manholes that lead directly to the feed alley.

It is most practical to place manholes either where the feeding places start or end and between groups.

The opening of manholes must be 0.40 metre where cows can walk perpendicularly into the opening. The opening

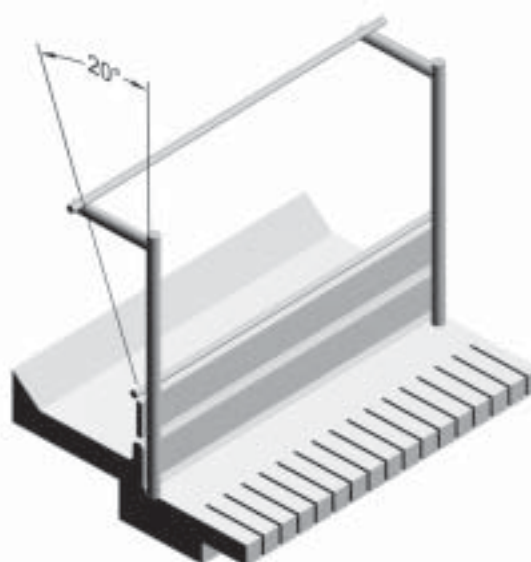

Figure 9.12.
Design of feeding
rack with neck rail.

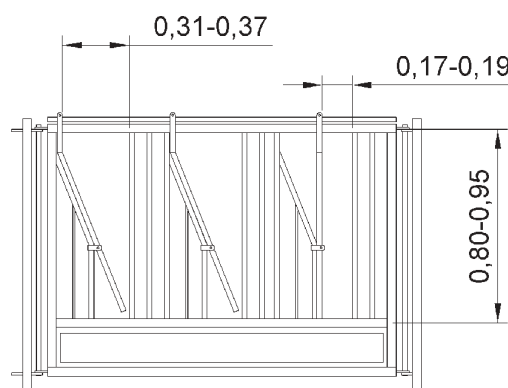

Figure 9.13
Measurements for
neck opening at the
top of the self-lock-
ing feed barrier
(CIGR, 1994).

Chapter 9

holes, where cows can only walk parallel with the hole, may be 0.50 metre. (See figure 9.14).

Landing and feeding platform

In case of solid floor with scrapers, cows will be disturbed by the manure scraper while they are eating at the feeding place. In order to reduce this problem, a landing or feeding platform may be

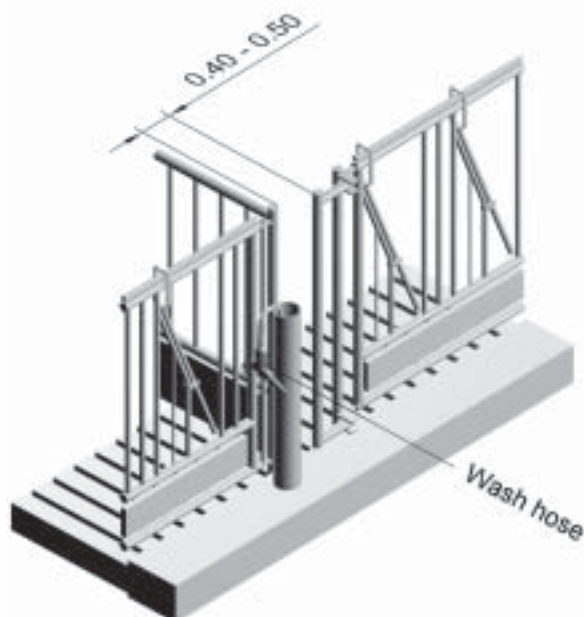

Figure 9.14.
Example of man-hole design.

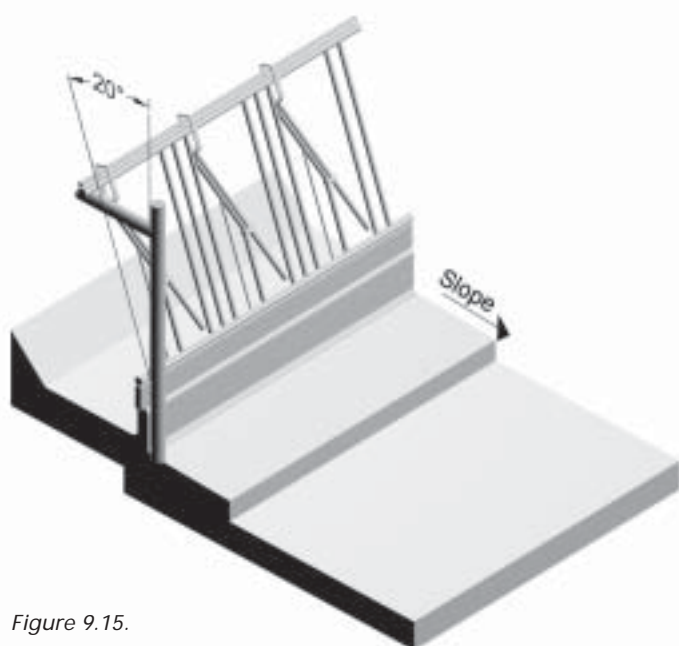

Figure 9.15.
Example of a landing at the feeding area.

provided. The height must be 0.10 metre above the cow alley. If a feeding platform is provided, the height of the neck rail and feeding rack must be adjusted to the platform.

A short feeding platform or landing for the forelegs should only be 0.50 +/- 0.10 metre wide, and it must be raised 0.10 metre above the alley. (See figure 9.15).

A long feeding platform for the entire body should at least be 1.60 metre in the length, and it must be raised 0.10 metre above the alley. Moreover, one partition should be mounted per feeding place to avoid lengthwise cow traffic on the platform. Feeding platforms may also be applied on farms with slatted floors and the platforms may be provided with rubber mats. (See figure 9.16).

The feeding platform must slope 2 – 3% towards the alley.

Feeding places with partitions will protect cows from being chased away and it will reduce the feed loss as the cow will draw feed sideways into the feeding place.

Automatic feeding stations

(Individual distribution by means of electronic steering)

Automatic feeders should be accessed from the feeding area to keep the resting area as quiet as possible. There must be enough space at the entrance to the automatic feeder, a minimum of 3.50 metres is preferable. The automatic feeder must protect the full body of the cow from attacks from waiting cows, and the inside width should be about 0.85 metre, so there is only room for one cow at a time.

At a distribution of 300 kilogrammes feed pellets per minute (maximum 14 hours per day and night), the automatic feeding station can serve a maximum of 25 cows at a time.

It is necessary to develop a protection gate behind the cow as well as a front exit as is the case with feeders in milking pens in connection with Automatic Milking Systems (AMS) and tandem stalls. For further information about automatic milk feeders for calves, please see chapter 8.3.2.1.

Drinking water allocation

For recommendations regarding drinking water allocation, design of water cups and water troughs as well as location of water troughs and cups, please see chapter 6.3.

Background and motivation

Behaviour

In loose housing systems the eating behaviour of cows is primarily influenced by the following factors:

- The number of automatic feeding station
- The number of feeding places
- The feeding rack design
- The supplied feed ration.

All cows should have the same opportunities of eating the planned feed ration.

If the amount of supplied feed is limited, there should be at least one feeding place at the feeding area per cow. Subsequently, the feeding place partitioning will be crucial for the dominating cows' possibility of chasing away weaker cows from the board (Metz, 1983).

Two to three cows per feeding place will reduce the time cows spend on eating and it will lead to an increased number of aggressions at the feeding area, but the feed intake and the yield will remain the same. Ad-lib feeding is of course a precondition for this (Henneberg et al., 1986; Collis et al., 1980; Albright & Timmons, 1984).

Cows' preferred feeding area is within 0.60 metre from the rear edge of the trough (Gjestang, 1983).

To prevent aggressive behaviour, it is recommended to keep a maximum of 25 to 30 cows per concentrate feeder (Maton and Daelemans, 1989; Candura and Gusman, 1989). This is confirmed by experiences in practice. However, the number of cows can be increased, if it is only a small amount, or if the concentrate is supplied in the milking parlour.

Feeding rack and trough

In case of vertical self-locking feed barriers, cows are able to get at feed within a trough distance of 0.98 metre and if the self-locking feed barrier slopes (20°) towards the trough, the cow can reach all feed within a distance of 1.12 metre (Pallesen, 1997; Hansen, 1999).

With a narrow trough and a vertical self-locking feed barrier, there will be a pressure of more than 500 Newton for 18 seconds during each feed distribution. The average of the largest pressures was about 1,000 Newton. A wide trough resulted in a pressure of more than 500 Newton for more than 100 seconds during each feed supply and on average the largest pressures amounted to 2,000 Newton. Experiments show that cows can and will press 2,000 Newton to get at the feed. At such high pressures there is a danger that cows might be seriously injured (Pallesen, 1997; Hansen, 1999).

By mounting a sloping (20°) feeding rack, the reach of cows will increase with 0.14 metre and it will be possible to apply wider and more spacious troughs without reducing the conditions of cows (Pallesen, 1997; Hansen, 1999).

At first the cow will eat the feed within a convenient reach. If there is some feed in the outer edge of the trough, cows will put an equal pressure on a vertical and a sloping feeding rack in order to get at the feed (Pallesen, 1997; Hansen, 1999).

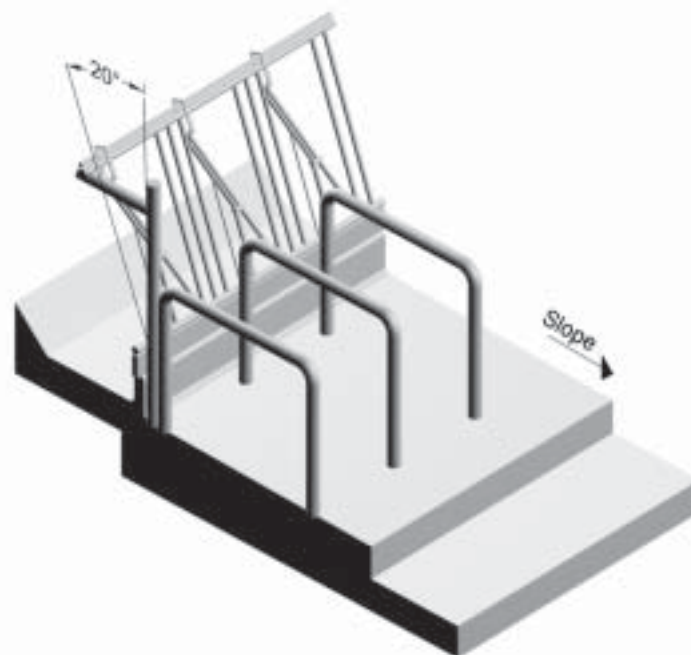

Figure 9.16.
Example of raised
feeding platform.

Chapter 9

Figure 9.17.
Principle sketches of four
differently designed cubi-
cle housing systems.

a)

One row of cubicles.
Plenty of room at the
feed area and a good
overview of the cubicles
from the feed alley.

b)

Two rows of cubicles.
Enough space for all cows
to eat at the same time
at the feeding area. Resting
area is separated from
feeding area. Possibility
of controlling cow traffic
in connection with AMS.

c)

Two rows of cubicles.
Double rows. Enough
space for all cows to eat
at the same time at the
feeding area. Close con-
tact with 2-5 other cows
in the cubicles. Cows are
in direct contact with
outer wall in the alleys.

d)

Three or several rows of
cubicles. Excellent utiliza-
tion of cow alleys. Re-
duced amount of feeding
places. Much traffic at the
feeding area. Cows are in
close contact with 2-5
other cows in the
cubicles.

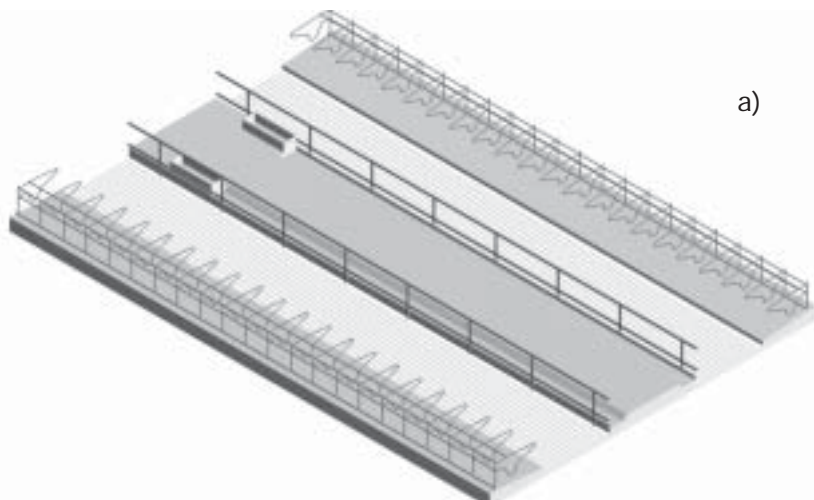

a)

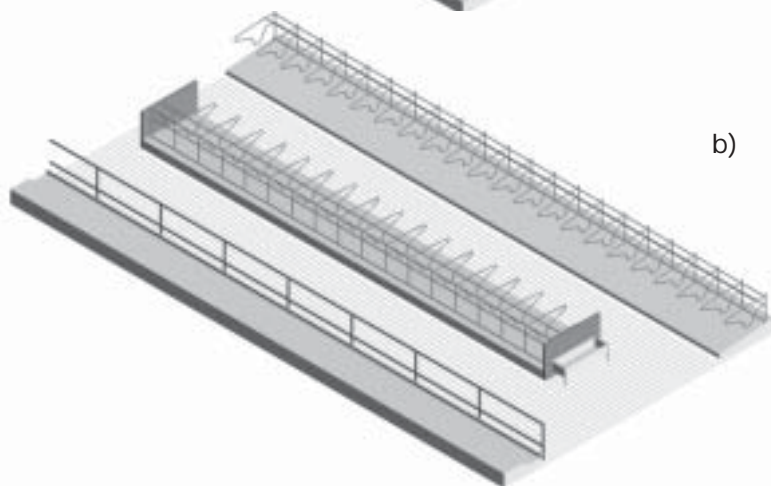

b)

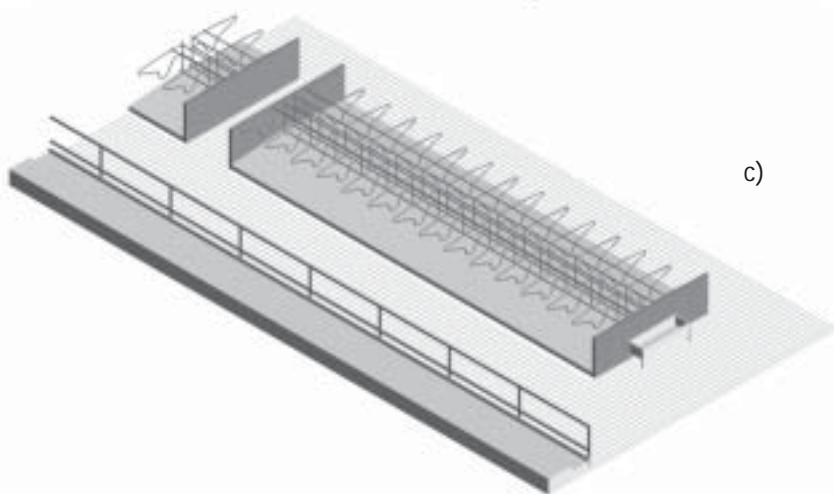

c)

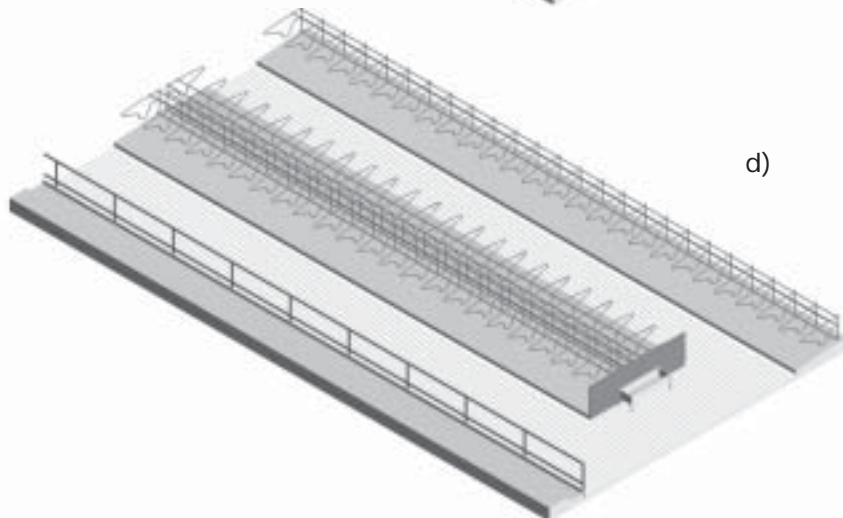

d)

To avoid too much damaging compressive stress, it is important to supply the food within the reach of the cow, which in the case of a 0.20 metre raised trough and a vertical feeding rack is 0.60 metre and in case of a sloping feeding rack is approx. 0.75 metre (Pallesen, 1997; Hansen, 1999).

Health

By lifting the height of the trough bottom above the feeding area level, the loading of the cow's forelegs is reduced (Boxberger, 1983).

The frequency of compressive stress is reduced by lifting the height of the trough bottom to 0.15 – 0.20 metre (Rom, 1989; Gjestang, 1983).

The frequency of compressive stress is reduced considerably when the width of the trough does not exceed 0.60 metre (Rom, 1989; Gjestang, 1983).

9.1.4 Walking alleys

Definition

The alleys of loose housing systems are used both as traffic and exercise areas and sometimes as traffic routes for the staff.

The floors of the alleys must have a sufficient carrying capacity for cows, machinery, etc. Moreover, the alleys must be slip resistant, preventing animal and man from slipping.

Cubicle alley floors can either be slatted or solid. The cleaning of alleys without slits must be carried out several times during the day, so that the

hoofs of the cows can be kept sufficiently clean and dry.

Recommendations

All alleys must be slip resistant. Moreover, the alley floor may either be slatted or solid. The alleys, the feeding area and the holding area, if any, make up the exercise area, which is at the cows' disposal. This area should account for approx. 4 m² per cow (cubicles exclusive) to reduce the aggressions, clashes and abnormal behaviour of cows. The minimum widths of the feeding area and the cow alleys are listed in table 9.4.

Crossovers or escape alleys should be established on each end of a cubicle section. If the cubicle row consists of more than 20 cubicles, the farmer must establish additional crossovers to achieve a free cow circulation.

Alleys with a width of less than 2.40 metres should not be closed at one end e.g. in housing with cubicles placed across and where the housing system is divided into sections.

In figure 9.17 principle sketches of four differently designed cubicle housings are shown.

Background and motivation

Behaviour

Limited space is one of the main reasons for aggressions among cattle. If the space is limited, cows will often meet each other at a close distance and at the same time the escape possibilities are limited (Metz and Wierenga, 1987).

Table 9.4. Minimum width of feeding area and cow alleys.

| Alleys between | Metre |
|---|-------|
| Feed alley – wall | 3.20 |
| Feed alley – cubicles a) one row | 3.20 |
| Feed alley – cubicles b) two rows | 3.40 |
| Feed alley – cubicles c) three rows or more/deep litter | 3.60 |
| Cubicles – cubicles | 2.40 |
| Cubicles – wall (free/clear passage) | 2.40 |
| Crossovers | 1.80 |
| Crossovers with drinking places including water trough | 3.60 |

a) One cubicle row for each feeding area side.
b) Two cubicle rows of for each feeding area side.
c) Three cubicle rows or more or deep litter for each feeding area side.

Chapter 9

The floors must be dry and slip resistant. The efficiency of slip resistant floors is primarily determined by means of the friction coefficient and the amount of manure and urine (Webb and Nilsson, 1983; Irps, 1983).

In general, cows defecate irregularly as regards time and locality. It is thus extremely difficult to control this behaviour in a way that cows dispose of manure/urine at the same place (Metz and Wierenga, 1987; Potter and Broom, 1987).

If the number of crossovers must be reduced to one, it is best to place this crossover at the end of the cubicle row instead of in the middle. Thus cows will come from two directions only instead of four (Potter and Broom, 1987).

Health

Hoof sufferings are most common in loose housing systems with wet and dirty alleys (Blom, 1982).

Moist floors will have the effect of soaking the sole horn and the skin between the hoofs. Thus foreign bodies and germs will easily penetrate into the hoof. Moreover, the risk of spreading infections is high (Maton, 1987).

Hoof rot among cows kept in cow houses with solid floor can be expected to develop faster, and veterinary treatments of other hoof sufferings are more common compared to cattle kept in slatted floor housing (Buchwald et al., 1982; Thyssen et al., 1982; Maton, 1987; Coehen, 1980).

Hoof trimming of all cows twice per year is supposed to have a considerable influence on the hoof health (Thyssen et al., 1985).

A higher incidence of limb sufferings were registered during the first lactation among cows kept on solid floor than cows on slatted floor (Thyssen et al., 1985).

A raised platform along the feeding place in connection with solid floor housing can cause cleaner and drier hoofs (Hultgren and Herlin, 1999).

Other conditions

There is a considerably higher air change in open rather than closed cow

houses. The theoretical air change with a medium wind speed of 5 m/s at right angles to a 12 metre broad building with open facades would be 1,500 times per hour (Strøm and Pedersen, 1999).

As the high air change results in cold buildings during cold periods, it is an important precondition for the thrive and welfare of cows that they have access to dry resting areas, which are free from draught, during the resting periods and that they are able to choose themselves when to rest (Strøm and Pedersen, 1999).

During summer the heat from uninsulated roof surfaces may cause problems, which must be taken into account, e.g. when choosing roof material (Strøm and Pedersen, 1999).

9.2. Milking area

Definition

The milking area is the area in which the cow stays while it is being milked two or several times per day.

The milking area is divided into a holding area, entrance part, milking stalls, exit part, return alley, hoof bathing and a separation area.

Recommendations

The milking area should provide comfort to the cow both within, during and immediately after the milking.

The construction and design of the milking area should ensure that the cow can move freely and easy without getting hurt or stressed.

9.2.1 Holding area

The holding area is the place where cows stay directly before milking. The holding area must ensure a constant and sliding intake of new cows while the milked cows leave the milking stalls.

An optimum supply of cows to the milking stalls very much depends on the design of the holding area. Figure 9.18 depicts a holding area.

Recommendations

A holding area should always be established. The holding area, the milking parlour room excluded, must be able to hold a group of cows.

Space requirements per cow

| | |
|-------------------|---------------------|
| Large breed, min. | 1.50 m ² |
| Jersey, min. | 1.35 m ² |

Cows should not stay more than one hour at the holding area.

The flooring must be absolutely slip resistant.

A long, narrow holding area is preferable to a short and broad or square holding area.

There must be an alignment passage from the holding area to the milking stalls.

Crowd gates with electric shock are not to be recommended.

The holding area should be well-lit and well-ventilated.

Background and motivation*Behaviour*

- Too little space and a bad climate will stress the cows unnecessarily
- If cows are kept in the holding area for a long time, they will have less time to eat and rest and thus the cow comfort and the production capacity will be reduced
- The milking stalls should not be used as holding area for the first cows that enter the stalls, as they will be stressed by the waiting time and as they might make the milking stalls unnecessarily dirty
- It is advantageous if the holding area slopes towards the milking stalls, as cows will thus place themselves in a way that they face the milking stalls and hence they are more willing to enter the milking stalls. A 5 – 7% slope appears to be appropriate.

Other conditions

- Cows in the holding area should be protected from injuries owing to pressure by mounting a smooth guard rail approximately 90 centimetre above the floor. The guard rail protects against sharp edges, pillars, wall surfaces and other equipment that may pose restrictions on cows (see figure 9.19). The distance between the wall and guard rail should be at least 10 centimetre. The guard

rail opening between rail and wall must be closed, so the leg of the cow does not stuck, if it jumps up the rail.

- A mechanical crowd gate that reduces the holding area, gradually, as cows walk into the milking stalls, will contribute to a uniform and constant funnelling of cows into the milking stalls
- On large farms in which cows are divided into groups, the holding area must be dimensioned according to the group size

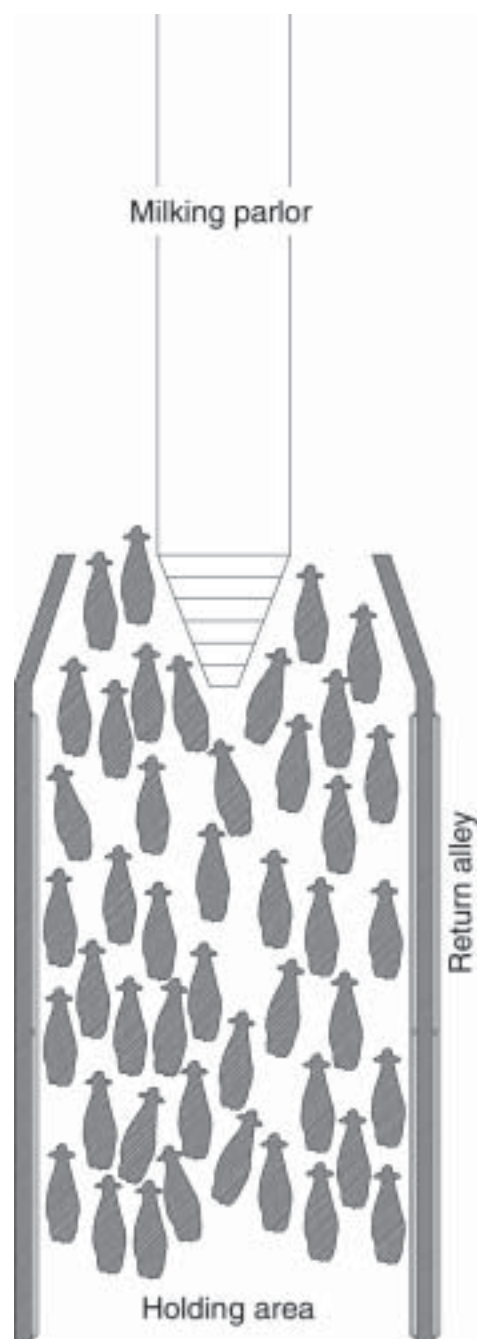

Figure 9.18.
Holding area.

Chapter 9

- If the milking must take place continuously while groups are changed, the area of the holding area must be increased with 25% according to the need of the largest group
- It is not recommended to omit the holding area, however, on small farms the cows are able to utilise the space between the cubicles, crossovers or the like as holding area in front of the milking parlour. If you choose this solution, the holding area must be dimensioned as follows:

| Space requirements per cow | |
|----------------------------|--------------------|
| Large breed, min. | 2.0 m ² |
| Jersey, min. | 1.5 m ² |

- If the holding area is placed between one or two rows of cubicles, the cubicles must be barred with a rail during milking. Thus the risk of injuries owing to pressure caused by partitions is reduced and the cubicle hygiene is easier to maintain
- Deep litter areas should not form part of the holding area.

9.2.2 Entrance part

There is an entrance part between the holding and milking stalls. The entrance part must ensure that the cows

will enter the milking stalls naturally and easily.

Recommendations

The passage between the holding area and milking stalls should be completely open, so cows can see what is happening in the milking parlour. The entrance part must by means of gates be funnel-shaped to make sure that cows will enter the milking stalls one by one. Steps or other differences in level of the entrance part must be avoided.

Background and motivation

Behaviour

- An open passage between the holding area and milking stalls will promote peace at the holding area. Moreover, an open passage will promote the well-being and the willingness to enter the milking stalls
- A funnel-shaped entrance will lead the cows naturally into a single row before they enter the milking stalls. At the same time the gates will protect the individual cow and in this way it is able to keep its place while it is waiting for access to the milking stalls. Figure 9.20 show an example of a funnel-shaped entrance part
- Steps at the entrance part will in the worst case make cows trip and be injured. In the best case cows will

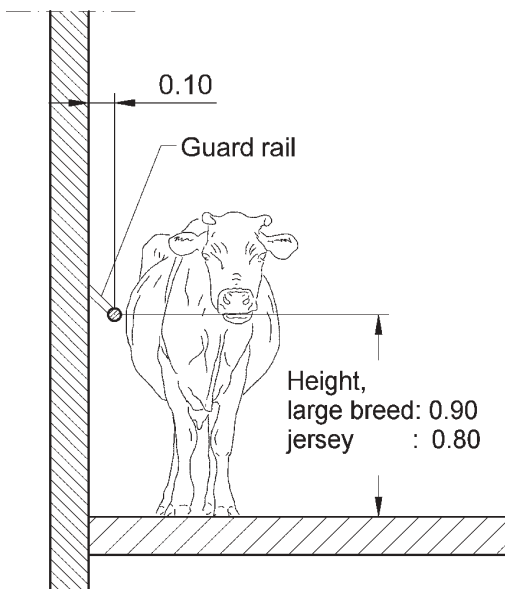
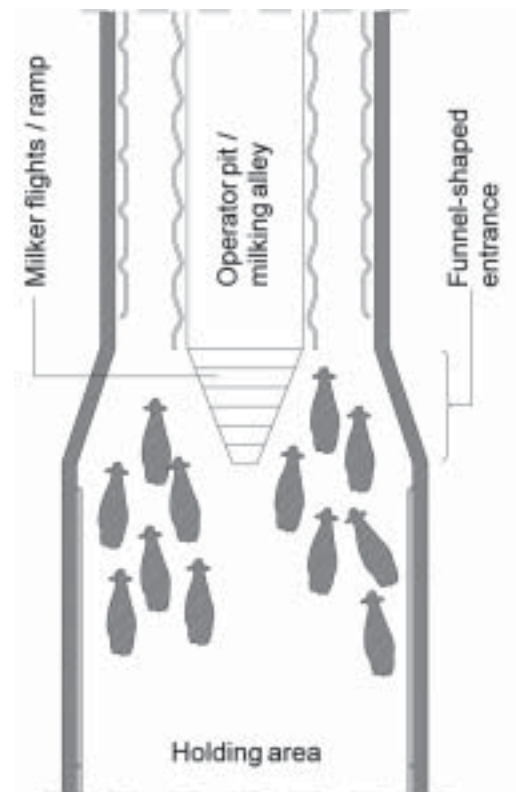

Figure 9.19
(Left)
Example of guard rail.

Figure 9.20.
(Right)
Milking parlour entrance part.



stop and this behaviour will reduce the capacity of the milking parlour.

Other conditions

- An funnel-shaped entrance part will provide the possibility of building a good flight of stairs in continuation of the milking passage/pit. In this way it should be easy for the milker to “go round the back” of a cow which is hesitating to walk into the milking parlour.

9.2.3 Milking stalls

Cows are milked in the milking stalls. The milking is carried out by means of a milking cluster, which is, basically, the same regardless of milking parlour type. However, the milking stalls can be designed in different ways, e.g. as a:

- Herringbone parlour
- Parallel parlour
- Tandem parlour
- Rotary milking parlour
- Automatic milking system (AMS).

The following recommendations apply to all the above-mentioned milking systems:

Recommendations

The milking stalls must have slip resistant and cleaning-friendly floors.

The cow should be able to stand naturally during milking.

Cows should be able to pass the milking stalls freely without running against the parlour equipment. The free distance between the equipment must be at least 0.90 metre (See figure 9.21).

Herringbone milking parlours, in which cows are placed in an angle of 50 or 60 degrees measured from the edge of the operator pit, are not to be recommended.

Background and motivation

Behaviour

- Normally, the willingness of cows to enter the milking stalls will be encouraged by supplying concentrate in feeders. At the same time, however, this will tempt cows to stay in the milking parlour after they have been milked.
- Equipment and/or feed boxes at the milking stalls may hinder the free passage of cows if the opening is less than 0.90 metre. This might re-

sult in a slow cow traffic and/or cow injuries

- Concentrate supply should be regarded as a precondition of tempting cows to be milked in automatic milking systems. The willingness to walk into the system can be increased further by supplying a tasty feedstuff
- It is difficult to “fill in” herringbone milking parlours, in which cows are placed in an angle of 50 or 60 degrees measured from the edge of the operator pit, if the width space is too narrow for the cows. However, if the space is made broader there is a risk that two cows might try to walk next to each other. In both situations the cow and the milker will be stressed. Those problems do not arise in well-proportioned 30 degree herringbone stalls with a milking stall width of about 150 centimetre (measured at right angles to the operator pit edge) and a length of 115 centimetre (measured along the operator pit edge).

Other conditions

- If the milking stall is raised and includes a holding area and two return alleys, it is possible to establish a milking alley (“an open operator pit”). Thus it is possible for the milk-

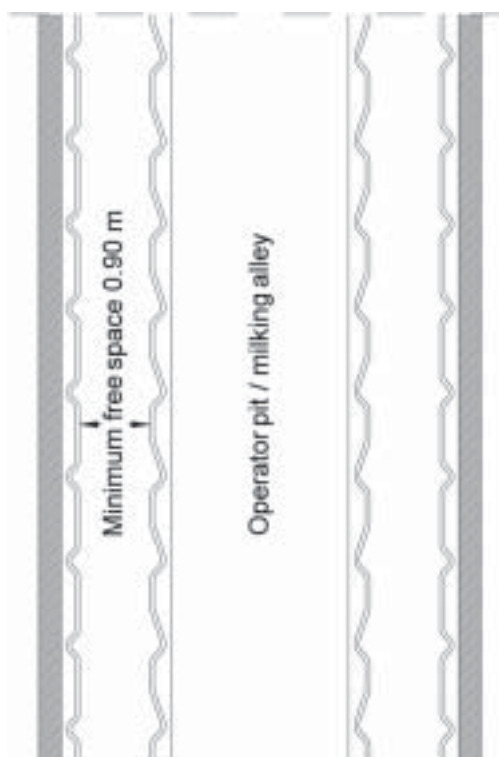

Figure 9.21.
Free passage for cows in milking parlour.

Chapter 9

er to enter the milking alley unobstructedly without a flight (this is also called a "milking eminence").

- The troughs for concentrate in the milking parlour must be easy to clean.

9.2.4 Exit part and return alleys

The area of the exit part starts when the cow leaves the milking stall and it lasts until the actual housing system starts or the separation area, if any. The cow must be able to move freely without being obstructed by equipment or building parts on its way back to the housing system.

Recommendations

It is optimal if the cow is able to leave the milking stall by walking straight forward.

If the cow has to make a 90 degree turn, the inside corner must be rounded off. This applies both to milking parlours and return alley, if any (See figure 9.22).

Walking lines with a 180 degree turning are not to be recommended.

Return alleys must be as short as possible.

Return alleys, which cows have to pass one by one, must have a free passage of 90 centimetre (effective free opening between equipment/guard rail).

A return alley, which two or more cows have to pass at the same time, must have a free passage of at least 180 centimetre (effective free opening between equipment/guard rail).

There should not be any steps or other differences in level of the exit part. It is not recommended to establish exit parts, which lead cows directly from the milking stalls or the return alley to the deep litter area.

Background and motivation

Behaviour

- The milking stalls are most easily and quietly emptied by letting cows walk straight forward towards the direct exit ("fast exit") after the milking. Direct exits are most common in tandem parlour and automatic milking systems and they can be established in herringbone (30 degree) and parallel parlours.
- In herringbone and parallel stalls with direct exits, sufficient space in front of the milking stalls must be provided. Normally, a width of about 300 centimetre in front of the milking

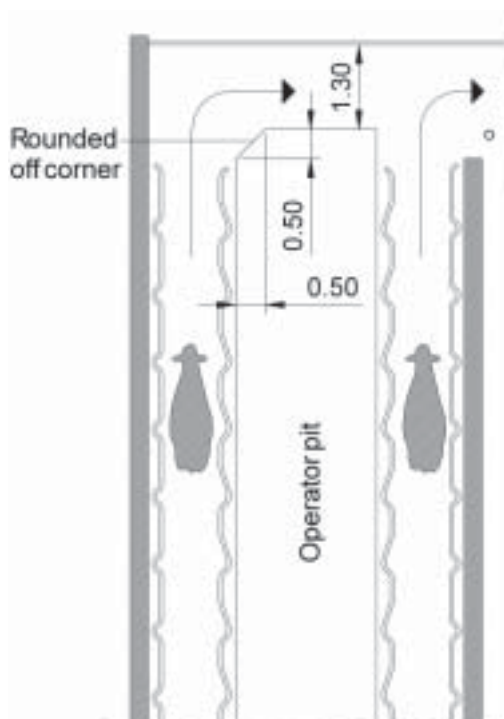

Figure 9.22.
(Left)
The inside corner must be rounded off when cows have to make a 90 degree turn in the milking parlour.

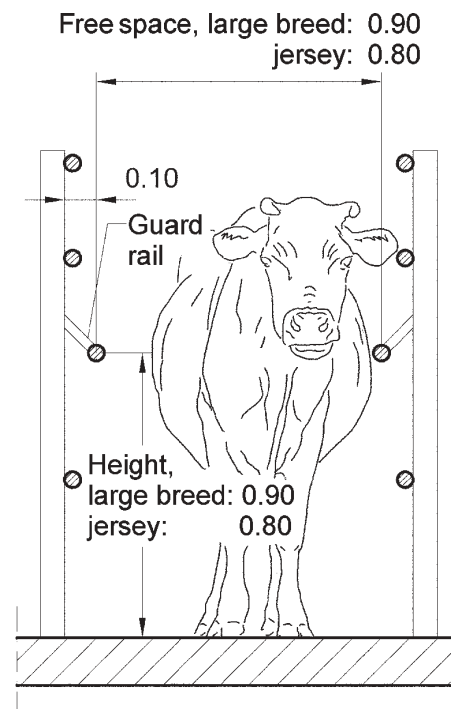

Figure 9.23.
(Right)
Example of guard rail placed in return alley.

stalls is enough to hold those cows that have left the milking stalls before they walk down the return alley

- If the cow wants to make a 90-degree turn, it will easily injure itself and at the same time the walking speed of the cow will be reduced (the milking parlour is emptied slowly). The rounding off of the inside corner of the walking line will facilitate the cow traffic. For further information, please see chapter 2.2 "Cattle movement pattern"
- The risk of injuries is even larger in connection with a 180-degree turn, which can therefore not be recommended. However, if it is necessary four angles of 45 degrees should be made
- It may be necessary to finish off the return alley by a one-way gate to prevent cows from returning to the milking parlour.

Health

- Cows should be protected from injuries owing to pressure in the return alley by mounting a smooth guard rail approximately 90 centimetre above the floor level. The guard rail protects against sharp edges, pillars, wall surfaces and other equipment that may pose restrictions on cows. The distance between the wall and guard rail should be at least 10 centimetre. The guard rail opening must be closed, so the leg of the cow does not stuck, if it jumps up the rail (see figure 9.23)
- Cows should not be able to lie down directly after milking, as the teat channels are still open and prone to micro organisms from the bedding
- Cows should be prevented from turning on slatted flooring elements as this activity will increase the risk of hoof injuries.

Additional information

- Steps at the exit part will in the worst case make cows trip and get hurt. The best situation would be if the cows stop, which will reduce the capacity of the milking parlour.

9.2.5 Hoof bathing

Hoof bathing provides the possibility of preventing/treating hoof sufferings among cattle.

Recommendations

A hoof bath must be established or it should at least be possible for cows to get a hoof bath with an appropriate disinfectant.

It is not to be recommended to add antibiotics to the hoof bath, as the environmental consequences have not been established yet.

Background and motivation

Behaviour

A hoof bath will constitute an obstacle to the cows and thus the speed of movement of cows is reduced. In order to reduce this problem, it is important to observe the following:

- A hoof bath is placed in the return alley farthest off the milking stalls
- The hoof bath must have the same width as the return alley and a depth of 15 centimetres. Moreover, it should be able to hold 10 centimetre of liquids
- The length of the hoof bath must be minimum 2.20 metre and there should be established a slope in both ends of the bath (a rise of 0.5 metre) (See figure 9.24)
- The drain should be established on the side of the hoof bath, so the cows will not be injured
- If a hoof bath cannot be built, there

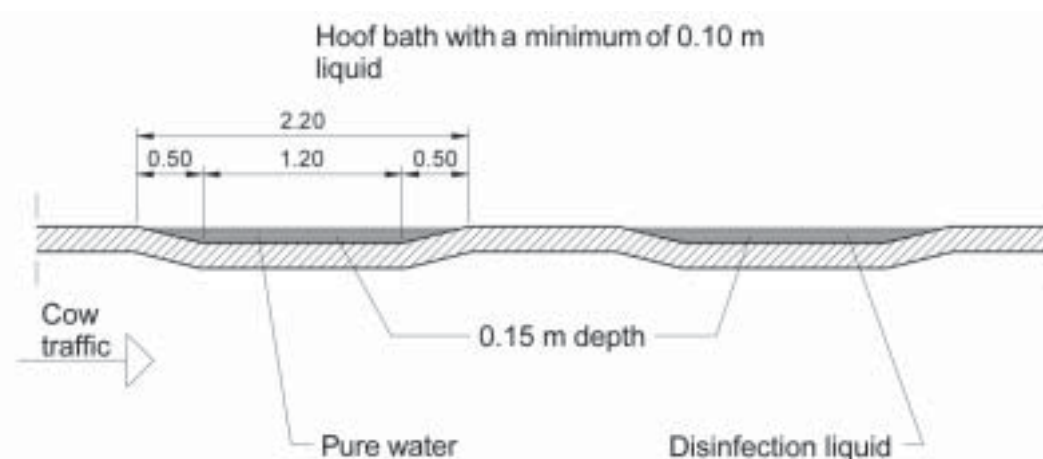

Figure 9.24. Hoof bath.

Chapter 9

should be room enough for a mobile mattress stained with disinfectant.

Health

- A hoof bath can be used partly as prevention and treatment of interdigital necrobacillosis
- In case of prevention, the hoof bath must be used one to two times per week or as required.

Additional information

- In order to limit the amount of dirt in the hoof bath, it is advantageous to establish an additional hoof bath with water only in front of the actual hoof bath
- The drain from the hoof bath must be made either by plastic or stainless steel.

9.2.6 Separation area

A separation area is the area in which cows that require a short-term treatment will stay for a couple of hours.

Recommendations

It is a good idea to separate cows in connection with the milking.

The separation area should be located close to the milking area.

Background and motivation

The separation area holds cattle, which are going to be inseminated or treated for diseases.

It might be an independent area or it may be a part of the normal housing area, which is temporarily (for a couple of hours) used for treatment or disease prevention.

Behaviour

- It should be possible for cows to eat, drink, exercise and rest in the separation area – preferably under circumstances that conform to the cow's normal housing conditions.

Additional information

- Cows may be separated manually or automatically
- It should be easy for the personnel to look after the cows in the separation area and thus it should be located at a place the personnel passes often during the day
- It should be easy to catch and fix cattle that need treatment, e.g. by means of self-locking feed barriers

- It should be easy to enter the area through manholes and/or small handy gates
- There should be a table near the separation for the treatment paraphernalia, etc. Moreover, a wash basin should be mounted in the table and it is also a good idea to establish shelves under or besides the table
- A separation gate near the milking stalls will disturb the cow traffic. Thus it should be considered whether it is most convenient to disturb the cow traffic or catch cows for treatment after milking
- If there is room for a whole group of cows from the milking parlour before the separation gate, the gate will not seem to disturb the cow traffic so much.

9.3 Tied-up housing system

Definition

Cows are tied up by tether or the like. The boxes serve both as resting and feeding area. Milking is carried out in the stalls.

Recommendations

| Dimensions | | |
|-------------------|--------|--------|
| | Length | Width |
| Large breed, min. | 1.75 m | 1.20 m |
| Jersey, min. | 1.60 m | 1.05 m |

The building of new tied-up housing systems is not to be recommended. This system limits the cow's possibility of movement and social behaviour compared to loose housing systems.

A large amount of existing tied-up housing systems work well. However, it would benefit cows of such housing systems to be at pasture during summer and, if possible, to exercise daily in an exercise fold during winter.

In this section it will be described in which ways existing tied-up housing systems can be maintained and improved.

9.3.1 Stall (resting area)

Stalls serve both as resting and feeding area. The stall spans from the rear edge of the trough to the front edge of the manure channel (see figure 9.25). The bedding can be concrete flooring or synthetic mats, a layer of litter is added on both bedding types.

Partitions

It is recommended that partitions, which start from the edge of the trough, are mounted between each stall. The length of the partition should be 1.00 metre in connection with large breeds and 0.90 in connection with Jersey cows.

Flooring type

The flooring of the stall must be dry, slip resistant and non-polishing, and the total length of the stalls should slope at least 2% to the rear.

Stalls should be littered with at least 0.5 kg straw two times per day. The amount of litter may in some cases be reduced in stalls with mats. It is advantageous to apply cut straw.

The ideal bedding is clean, dry, deformable, isolating and slip resistant.

Background and motivation

Cows need sufficient space during the lying down/getting up movement. The effective length of the stall is the distance from the rear kerb of the stall to the spot to which the tether can be drawn, when the cow rises. The largest cows must be taken into account (average of the 20% largest cows) in connection with the dimensioning.

9.3.2 Feeding area

The stall does among other things serve as feeding area in tied-up housing systems.

Recommendations

The trough design

The bottom of the trough must be about 0.15 metre above the bedding level. The in-flexible part of the rear edge of the trough should not exceed the bedding with more than 0.25 metre. If the farmer wishes to establish a higher rear edge of the trough to reduce the feed waste, a flexible, elastic piece of material can be mounted on top of the rear edge.

Design and location of watering cups

For further information about recommendations for water allocation, design and placement of watering cups and water troughs, please see chapter 6.3.

Background and motivation

The trough design and tether type have crucial effects on the eating behaviour

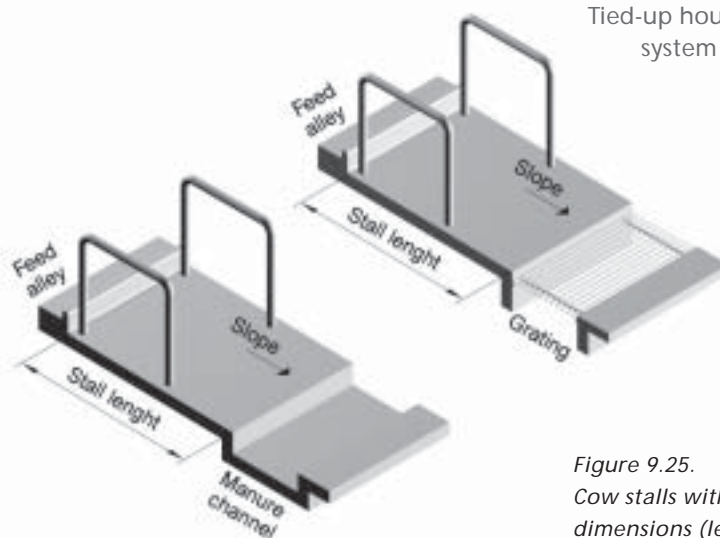

Figure 9.25. Cow stalls with dimensions (length and width).

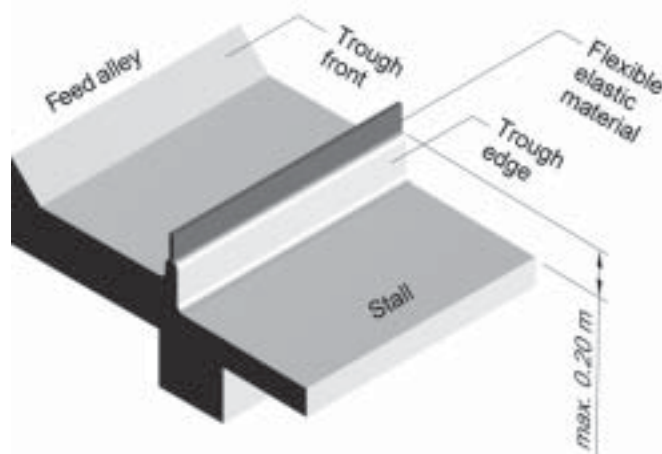

Figure 9.26 Trough design (principle construction in tied-up housing system).

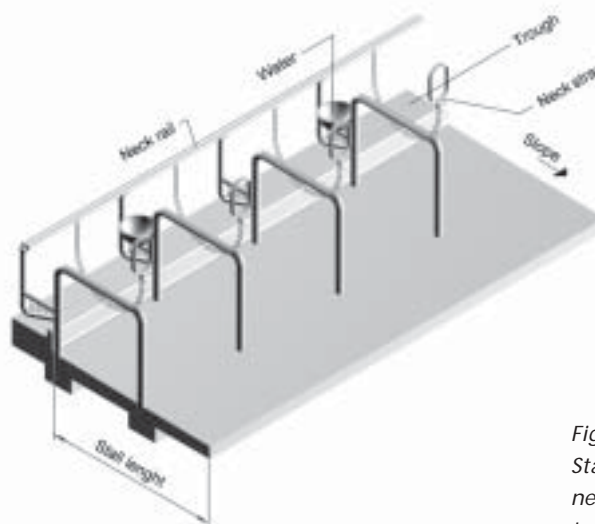

Figure 9.27. Stall partition with neck rail tether, water and trough.

Chapter 9

of cows. The design of the trough should make sure that the cow can easily get at the feed. Moreover, it should make allowance for the space requirements of cows when they lie down, get up and rest.

9.3.3 Tethers

Recommendations

Tethers should facilitate the greatest possible freedom of movement and it should not cause physical injuries.

The neck rail tether

The neck rail tether is a tether type where cows wear neck straps, which by means of a chain is fastened to a neck rail, which is placed in the front.

Placement of neck rail

| | |
|--|--------|
| Horizontal distance to rear edge of trough | 0.25 m |
|--|--------|

Vertical distance to the bedding

| | |
|-------------|-----------------|
| Large breed | 0.85 m +/- 0.05 |
| Jersey | 0.80 m +/- 0.05 |

The effective chain length

| | |
|------|--------|
| Min. | 0.80 m |
|------|--------|

Cows should not wear chains when they are at pasture. An alternative could be to tie the chain to the neck strap or to apply shorter chains during summer (0.60 metre).

Sliding chain collar tying

This is a tether type where the neck strap is fastened by means of double cow chains to two sliding poles that are mounted to the partition rails on each side of the stall.

Placement of neck rail

| | |
|--|--------|
| Horizontal distance to rear edge of trough | 0.30 m |
|--|--------|

Vertical distance to the bedding

| | |
|-------------|-----------------|
| Large breed | 0.85 m +/- 0.05 |
| Jersey | 0.80 m +/- 0.05 |

However, it is not necessary to apply a neck rail to make the sliding chain collar tying work.

Sliding chain collar tying

Length

| | |
|-------------------|--------|
| Double cow chains | 0.70 m |
| Sliding poles | 0.45 m |

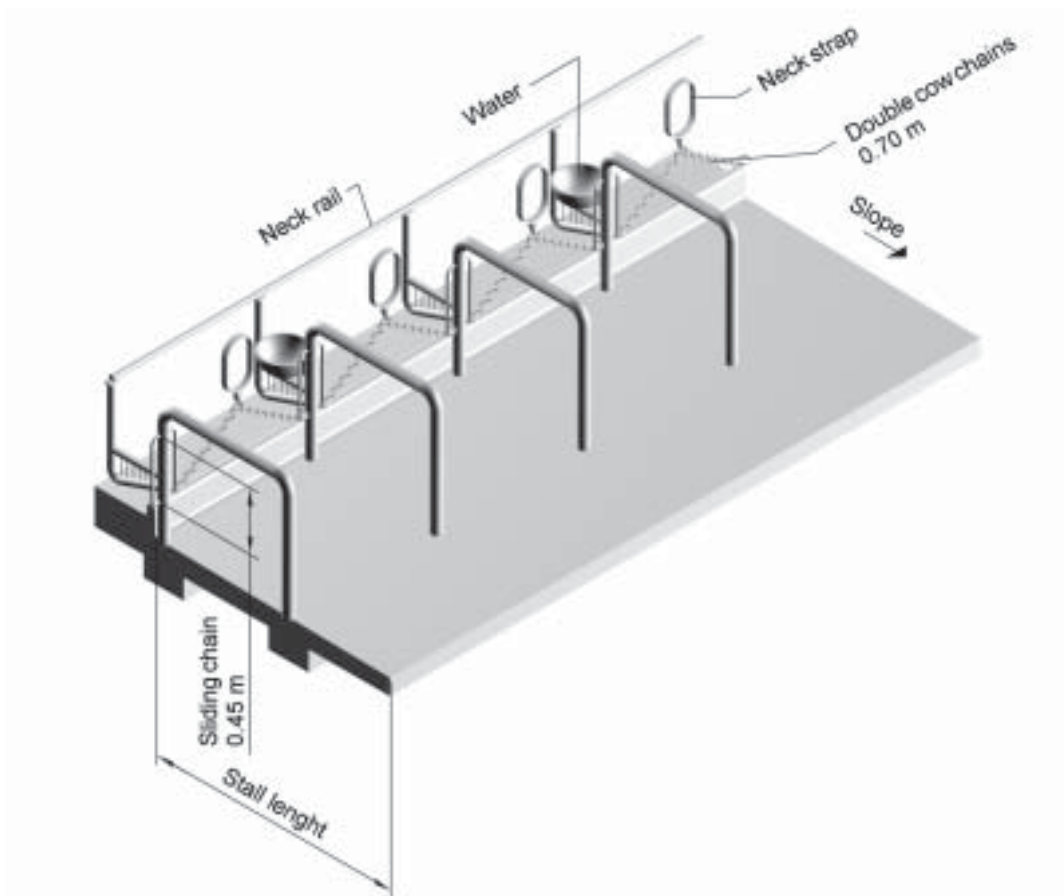

Figure 9.28. Cubicle partition with sliding chain collar tying, water and trough.

Background and motivation

The tether should allow the cow to move back and forward when it rises and reclines. Moreover, it should be possible for the cow to lick most of its body and eat without placing itself in awkward postures at the risk of sliding. The cow should also be able to place itself in a natural resting posture, lying as well as standing. Finally, it should be possible for the cow to step back, so the manure and urine will fall down onto the manure channel and not the bedding of the stall.

Behaviour

The sliding chain collar tying will limit the movements of the cow as well as its ability to lie down and carry out its grooming behaviour (Munksgaard & Krohn, 1990; Zeeb, 1968; Mortensen, 1971).

Vertical chain tether will limit the freedom of movement when the cow lies down and gets up (Mortensen, 1971).

The tether types with shoulder or neck rails will limit the cow's ability to lean over the feed trough (Mortensen, 1971; Munksgaard & Krohn, 1990).

9.3.4 Cow control equipment

Cow trainers

An electric trainer (U-shaped or inverted T) which is placed above the back of the cow in order to make it move backwards in the pen right before it urinates or defecates.

Recommendations

It is not recommended to use electric trainers. However, if it is found necessary in order to keep the stall clean, it is recommended that the cow trainer is only switched on one to two times per week and the following requirements should be observed (Statens Landbrugsstyrelsen, 1998):

Placement

| | |
|--|-----------------|
| From the front edge of the stall / back edge of the trough | 0.65 +/- 0.05 m |
| Min. distance to highest spot on cow back | 0.05 m |

Voltage

The max. voltage should be 3,000 (the voltage of a common outdoor electric fence cannot be applied).

A max. pulse energy of 0.1 joule.

It should be indicated whether the electric trainer is on or not.

To protect cows against unintended and constant shock, the voltage must switch off automatically, if the cow receives four to five shocks in succession.

Application

Individually adjustable (height – length – electric connection).

The adjustment should be checked (it should be possible to adjust the electric trainer without any tools) at least once per day.

The electric trainer should not be applied in connection with:

- Sick cows
- Cows on heat
- Down-calving cows.

Behaviour

- As regards behaviour cows react violently to electric shock (Lefcourt, 1986)
- The electric trainer limits the possibility of cow's to stretch and buck its back
- The electric trainer limits the possibility of cows to carry out grooming. Thus cows may execute abnormal movements and hence there is a high risk that cows may slip.

9.3.5 Walking alleys

Recommendations

The following alley width measurements should be regarded as minimum measurements and they must be adapted to needs and according to those machines that should pass the alleys:

Back alleys:

- 1.40 metre between inside wall and manure channel.
- 1.20 metre between two manure channels.

Crossovers:

- 2.40 metres if forage wagon and cattle must pass through.
- 1.20 metre if staff should pass.

Feed alley:

- (Motor-driven forage wagon transport)
- 2.20 metres between inside walls and the rear edge of trough.
- 2.60 metres between two trough rear edges.

Chapter 9

Feed alley:

(Tractor and wagon transport)

3.80 metres between inside wall and rear edge of trough.

4.20 metres between two trough rear edges.

9.4 Catch-stall housing system

Definition

A catch-stall is a housing system in which cows are "caught" in stalls by means of halters, catching rails or chains behind the cow. The stalls serve both as feeding and resting area, while milking is carried out in a milking parlour.

Recommendations

Catch-stall housing systems are not to be recommended due to the following reasons:

- Bad stall hygiene, as cows may drag manure from the alleys into the stall
- The stalls are often relatively short, as an attempt to keep the stalls clean. Thus cows run the risk of pressure damage, as they lie out over the rear kerb of the stall
- In connection with heavy types of tether cows may be injured due to long, loose-suspended chains, especially, if a ball is attached to the end of the chain. This is not to be recommended, as these catching devices can cause knee injuries
- In order to make sure that the cows are caught in the stalls certain tether types require equipment that may restrain the freedom of movement and the possibility of grooming too much
- As cows can freely choose stall after their own choice after milking, the farmer will lose the general view (cow certificate) of the cows. (Rådum et al., 1982).

9.5 Literature

9.5.1 Sources

Albright, L.D. & H.B. Timmons. 1984. Behaviour of dairy cattle in the stall housing. *Transaction of the ASAE* 27:4:1119-1126.

Andrae, U. & D. Smidt. 1982. Behavioural alteration in young cattle on slatted floors. In "Disturbed behaviour in farm animals". *Hohenheimer Arbeiten* 121:51-60.

Anonym. 1994. Strøede staldsystemer - Orienterende brugerundersøgelse, Produktudvikling af Staldsystemer til kvæg - rapport nr. 94.01. Landbrugets Rådgivningscenter. 34 pp.

Anonym. 1998. Godkjenningskrav og regler for bruk av kutrener. Landbruksstilsynet i Norge. 8 pp.

Blom, J. Y. 1981. Trykninger og andre fysiske skader på malkekøer ved forskellig staldindretning. I. Østergaard, V. & J. Hindhede (eds.) *Kostalde, miljø, sundhed og produktion*. 515. Beretn. Statens Husdyrbrugsforsøg. 73-104 pp.

Blom, J. Y. 1982. Forekomst af kliniske klovlidelser hos malkekøer i forskelligt staldmiljø. 532. Beretn. Statens Husdyrbrugsforsøg, København. 128-140 pp.

Blom, J. Y., J. Arnbjerg & K. Nielsen. 1983. Traumatisk skader hos malkekøer under forskellige staldforhold. *Dansk Vet. Tidsskr.* 66:19:881-887.

Boxberger, J. 1983. Wichtige Verhaltensparameter von Kühen als Grundlage zur Verbesserung der Stalleinrichtung. *Weihenstephan*. 173 pp.

Buchwald, E., J. Y. Blom, H. H. Smedegaard & I. Thysen. 1982. Klovsundhedens afhængighed af gulvtype og lejetype. 532. Beret. Statens Husdyrbrugsforsøg, København. 109-120 pp.

Candurra A., & A. Gusman. 1989. The automatic feeder influence on milking cows schelters design. *Agricultural Engineering* 2:887-892.

Cermak, J. 1987. The design of cubicles for British Friesian dairy cows with reference to body weight and dimensions, spatial behaviour and upper leg lameness. In: Wierenga, H.K. & D.J. Peterse (eds.) *Cattle housing systems, lameness and behaviour*. Martinus Nijhoff Publishers. 119-129 pp.

Christensen, P. M. 1998. Betydning af lejets hældning for liggeadfærd og drøvtygning hos køer. *Speciale i Kvægproduktion*. Institut for Husdyrbrug og Husdyrsundhed. Den Kgl. Veterinær- og Landbohøjskole, Frederiksberg. 98 pp.

- CIGR Design Recommendations Dairy Cow Housing. 1994. Report of CIGR Section II. Working group no. 14 ADAS, Martyr Worthy Winchester, SO21 1 AP, England. 56 pp.
- Coehen, J. 1980. Mehr Augenmerk den Klauen schenken. In "DLG-Mitteilungen" 95:1270-1272.
- Colam-Ainsworth, P., G. A. Lunn, R. C. Thomas & R. G. Edy. Behaviour of cows in cubicles and its possible relationship with laminitis in replacement dairy heifers. *Vet. Rec.* 1989, 125, 573-575.
- Collis, K. A., M. J. Vagg, D. T. Gleed, C. M. Copp & B. F. Sansom. 1980. The effect of reducing manger space on dairy cow behaviour and production. *Vet. Rec.* 30, 197-198.
- Gebremedhin, K. G., C. O. Cramer & H. J. Larsen. 1985 Preference of dairy cattle for stall options in free stall housing. *Transactions of the ASAE*, 28:1637-1640.
- Gjestang, K. E. m.fl., 1979. Inredning og teknisk udstyr for små løsdriftsfjøs, NJF - utredning/rapport nr. 9.
- Gjestang, K. E. m.fl. 1983. Utformning av små løsdriftsfjøs (20-30 kyr). NJF-seminar nr. 38. IBT-Rapport nr. 190.
- Gjestang, K. E. 1983. Feeding table geometry for dairy cows. *Transactions of the ASAE*. 890-892.
- Hansen, K. 1983. Dybstrøelse til malkekøer, Tre forskellige typer. *Orientering nr. 79*. Statens Jordbrugstekniske Forsøg. 31 pp.
- Hansen, K. 1984. Gulve i kvægstalde. *Orientering nr. 28*. SJF Bygholm, 10 pp.
- Hansen, K. og P. Keller. 1991. Løsdriftstalder med dybstrøelse til malkekøer. Spørgeundersøgelse. *Orientering nr. 75*. Statens Jordbrugstekniske Forsøg. 42 pp.
- Hansen, K., J. Strøm & S. Sigurdsson. 1999. Lejebelægninger i sengebåse til køer, Grøn Viden nr. 12. Danmarks Jordbrugsforskning. 8 pp.
- Hansen, K. 1999. Vurdering af inventarets udformning og placering ud fra køernes trykpåvirkninger. NJF, Sektion VII-Teknik, Workshop nr. 5. Indretning af sengestalde.
- Hansson, M. og J. Wahlander. 1991. Foderliggbås för mjölkkor. Sveriges Lantbruksuniversitet, Institutionen för husdjurens utfodring och vård.
- Henneberg, U., L. Munksgaard, E. S. Kristensen, S. P. Konggaard & V. Østergaard. 1986. Malkekøers Adfærd og produktion ved forskellige belægning i sengestalde. 613. Beret. Statens Husdyrbrugsforsøg. 61 pp.
- Herlin, A., P. Michanek & M. Magnusson. 1994. Fecal contamination og the lying area for dairy cows in different housing systems. *Swedish Journal of agricultural Research* 4. 171-176 pp.
- Irish, W. W. & R. O. Martin. 1983. Design consideration for free stalls. *Dairy Housing II: Proceedings of second National Dairy Housing Conference, march 14-16, 1983, Madison, Wisconsin*. ASAE SP 4-83:108-121.
- Irps, H. 1983. Results of research projects into flooring preferences of cattle. In: Baxter, S.H., M.R. Baxter & J.A.C. MacCormack (eds.) *Farm animal housing and welfare*. Nijhoff. 200-214 pp.
- Jensen, P., Recén & J. Ekesbo. 1988. Preference of loose housed dairy cows for two different cubicle floor coverings. *Swedish Agric. Res.* 18:141-146.
- Jørgensen, J. C., S. Eriksen, O. Kristensen, K. Hansen, P. Keller og H. B. Rom, 1990. Stalde med trædeudmugning. *Orientering nr. 70*. Statens Jordbrugstekniske Forsøg. 17 pp.
- Kirchner, M. & J. Boxberger. 1987. Loading of the claws and the consequences for the design of slatted floor. In: Wierenga, H.K. & D.J. Peterse (eds.) *Cattle housing systems, lameness and behaviour*. Martinus Nijhoff Publishers. 37-45 pp.
- Lefcourt, A. M., S. Kahl & R. M. Akers. Correlation of indices of stress with intensity and electrical shock for cows. *J. Dairy Sci.* 1986, 69, 833-842.
- Maton, A. 1987. The influence of the housing system on claw disorders with dairy cows. In: Wierenga, H. K. & D. J. Petersen (eds.) *Cattle housing systems, lameness and behaviour*. Martinus Nijhoff Publishers. 151-159 pp.
- Maton, A. & J. Daelemans. 1989. Modern housing of cattle and their welfare. *Agricultural Engineering* 2:921-925.
- Metz, J. H. M. 1981. Social reactions of cows when crowded. *App. Anim. Ethol.* 4:384-385.
- Metz, J. H. M. 1983. Food competition in cattle. In: S. H. Baxter, M. R. Baxter & J. A. C. MacCormack (eds.) *Farm animal housing and welfare*. Martinus Nijhoff Publishers.
- Metz, J. H. M. & P. Mekking. 1984. Crowding phenomena in dairy cows as related to available idling space in cubicle housing systems. *App. Anim. Behav. Sci.* 12, 63-78 pp.

Chapter 9

- Metz, J. H. M. & H. K. Wierenga. 1984. Spatial requirements and lying behaviour of cows in loose housing system. In: Unshelm, J., G. van Putten, K. Zeeb (eds.) Proceedings of the international congress on applied ethology in farm animals (Kiel). KTBL Darmstadt. 179-183 pp.
- Metz, J. H. M. 1984. The reactions of cows to a short-term deprivation of lying. *App. Anim. Behav. Sci.* 13:301-307.
- Metz, J. H. M. & H. K. Wierenga. 1987. Behavioural criteria for the design of housing systems for cattle. In: Wierenga, H.K. & D. J. Petersen (eds.) Cattle housing systems, lameness and behaviour. Martinus Nijhoff Publishers. 14-26 pp.
- Mortensen, B. 1971. Forsøg med bindsler til køer. 1.33. SBI Landbrugsbyggeri. Statens Byggeforskningsinstitut. 156 pp.
- Munksgaard, L. & C. C. Krohn. 1990. Koens nærmiljø. Forsøg med forskellige bindseltyper og udformninger af foderbordet. Beret. fra Statens Husdyrbrugsforsøg, Foulum.
- Natzke, R. P., D. R. Ray & R. W. Everett. 1982. Cow preference for free stall surface material. *J. Dairy Sci.* 65:146-153.
- Näsi, M. & H. Saloniemi. 1981. Effect of environmental change on injuries of udder and legs in dairy cows. *Nord. Vet. Med.* 33:185-193.
- Pallesen, C. N. 1997. Foderpladsens udformning i løsdriftstalder til kvæg, speciale, M.Sc. i kvægproduktion. Institut for Husdyrbrug og Husdyrsundhed. Den Kgl. Veterinær- og Landbohøjskole, Frederiksberg. 129 pp.
- Potter, M. J. & D. M. Broom. 1987. The behaviour and welfare of cows in relation to cubicle house design. In: Wierenga, H. K. & D. J. Petersen (eds.) Cattle housing systems, lameness and behaviour. Martinus Nijhoff Publishers. 129-151 pp.
- Rom, H. B. 1989. Koens Nærmiljø. Beretning nr. 42, Statens jordbrugstekniske Forsøg, 59 pp.
- Rådum, A., B. Mortensen & N. O. Olesen. 1982. Fodersengestalde, SBI-meddelelse nr. 18, Statens Byggeforskningsinstitut.
- Rådum, A., B. Mortensen & N. O. Olesen. 1982. Fangbåsestalde. SBI-meddelelse nr. 26 - Statens Byggeforskningsinstitut. 28 pp.
- Schopper, D. et al. 1989. *Tierärztl. Umschau*, 44, 72-78 pp.
- Smidt, M., M. Jørgensen, Aa. Møller-Medesen, H. Jensen, Z. Horvath, P. Keller & S. P. Konggaard. 1985. Halm som strøelse til malkekøer. 593. Beret. Statens Husdyrbrugsforsøg. 90 pp.
- Statens Landbruketilsyn, Norge, 06.07.98. Retningslinjer for bruk av kutrener.
- Strøm, J. & J. Pedersen. 1999. Åbne stalde, Grøn Videns nr. 16. Danmarks Jordbrugsforskning. 6 pp.
- Thyssen, I., E. Buchwald, J. Y. Blom & H. H. Smedegaard. 1982. Staldtypens og staldindretningens betydning for klovsundheden hos malkekøen. 532. Beret. Statens Husdyrbrugsforsøg, København. 141-152 pp.
- Thyssen I., J. Y. Blom & K. Nielsen. 1985. Klov- og benlidelser, reproduktionssygdomme samt fordøjelses- og stofskiftesygdomme hos malkekøer ved forskellig staldtype og staldindretning. 588. Beret. Statens Husdyrbrugsforsøg, København. 83-103 pp.
- Wierenga, H. K. 1983. The influence of the space for walking and lying in a cubicle system on the behaviour of dairy cattle. In: (eds. Baxter, S. H., M. R. Baxter & J. H. C. MacCormack) Farm animal housing and welfare. Martinus Nijhoff Publishers. 171-181 pp.
- Wierenga, H. K. & H. Hopster. 1989. The importance of cubicles for dairy cows. Submitted to *App. Anim. Beh. Sci.* June 30th 1989.

9.5.2 Supplementary literature

- Anonym. 1995. Malkestaldsguide. Alfa-Laval Agri A/S. 90 pp
- Anonym. 1997. Dairy Freestall Housing and Equipment. 6. udg. MWPS-7. Iowa State University, Ames, Iowa. 136 pp. ISBN 0-89373-087-4.
- Anonym. 1997. Malkecenter - anbefalinger og ideer. Danske bygningskonsulenter. Landbrugets Rådgivningscenter. 48 pp.
- Anonym. 2000. Sand i sengebåse - Orienterende brugerundersøgelse, Produktudvikling af Staldsystemer til kvæg - rapport nr. 00.01. Landbrugets Rådgivningscenter. 26 pp.
- Bickert, W. G. & R. R. Stowell. 1997. Plan Guide for free stall systems. 2. udg. W.D. Hoard & Sons Co., 28 Milwaukee Av. W., Fort Atkinson WI 53538, USA. 41 pp. ISBN 0-932147-30-5
- Bergsten C., J. Hultgren. 1996. The development of loose housing system for dairy cows to improve the health of their feet. Program and

- Abstracts for The International Symposium on Disorders of Ruminant, Digit and The International Conference on Lameness in Cattle. Mitzpeh Rachel, Jerusalem april 1999. 54 pp.
- Clemmensen, A. 1998. Intern håndtering af halm - Orienterende brugerundersøgelse, Produktudvikling af Staldsystemer til kvæg - rapport nr. 98.01. Landbrugets Rådgivningscenter. 64 pp.
- Dalgaard, I. 1999. Måtter og madrasser i sengebåse - Orienterende brugerundersøgelse - del I, Produktudvikling af Staldsystemer til kvæg - rapport nr. 99.01. Landbrugets Rådgivningscenter. 61 pp.
- Dalgaard, I. 2000. Måtter og madrasser i sengebåse - del II. FarmTest - Kvæg Nr. 1 - 2000. Landbrugets Rådgivningscenter. (1 tryk).
- Hansen, K., J. Strøm, M. Levring & S. Sigurdson. 1999. Karakterisering af måtter og madrasser til sengebåse for køer. Intern rapport nr. 122. Danmarks Jordbrugsforskning.
- Hultgren, J. & A. Herlin. 1999. Stallutformning och kohälsa, hygien, ätbeteende, juver- och klovhälsa hos bundna och lösgående kor. Svensk Mjölks Djurhälso- och utfodringskonferens, Borås 1999. 51- 53 pp.
- Keller, P. 1994. Håndtering af støelse og gødningsmätte i dybstrøelsestalde. Beretning nr. 58. Statens Jordbrugstekniske Forsøg. 22 pp.
- Kromann, H. 1993. Vejledning i indretning af mælkerum. Landbrugets Rådgivningscenter. 37 pp.
- Olsen, N. O. 1985. Vandinstallationer i kostalde. Malkekøers drikkeadfærd. SBI-Landbrugsbyggeri 65. Statens Byggeforskningsinstitut. 50 pp.
- Oswald, T. 1992. Der Kuhtrainer FAT-Bericht nr. 37 Eidg. Forschungsanstalt für Betriebswirtschaft und Landtechnik, Tänikon, Switzerland.
- Rasmussen, J. B., L. Jepsen, M. D. Rasmussen, S. Clausen, O. Kristensen 1999. AMS - Automatiske malkesystemer. Landbrugets Rådgivningscenter. 26 pp. ISBN 87-7470-738-6.
- Reinemann, D. J. 1996. Milking Cenet Options. Stepping into the Future. Four State Dairy Extension Conference 1996. University of Wisconsin - madison. USA. 8 pp.
- Rørbech, N. & B. Mortensen. 1983. Funktionsbeskrivelse for stalde til malkekøer. 31. SBI-medd. Statens Byggeforskningsinstitut. 98 pp.
- Saloniemi, H. 1980. Udder diseases in dairy cows - Field observations on incidence somatic and environmental factors and control. J. Scient. Agric. Soc. of Finl. 52:85-184.
- Sommer, T. 1985. Untersuchungen zur Tiergerechtheit praxisüblicher Gestaltung von Lauf-flächen für Milchvieh im Boxenlaufstall. Liz. Arbeit, Zool. Inst., Bern.
- Ugelvig, O., P. Justesen & H. Kromann. 1997. Malkecenter, malkerutiner og staldindretning. Mejeriforeningen, Århus. 57 pp.

The design of beef cattle housing systems does not differ considerably from the design of dairy cow housing systems. However, some adjustments need to be made as the majority of the breeds is larger than the dairy breeds and they may have horns.

Recommendations

Deep litter housing systems with littered resting area and separate feeding area with solid floor (possibly slatted floor) are to be preferred.

Calving time and choice of strategy for fattening male animals have considerable influence on the herd housing requirements. Focus is especially on autumn calving as opposed to spring calving and whether the bull calves are delivered as beef calves, young bulls or bullocks.

10.1 Weight and body dimensions

Table 10.1 shows birth weight, 200-day and 365-day weights of various beef cattle breeds. Table 10.2 shows beef bull body dimensions dependent on weight when the animals are approximately one year old.

Table 10.3 shows the weight and body dimensions among full-grown female animals of different beef cattle breeds.

10.2 Feeding and resting areas

Generally beef cattle are larger than dairy cattle breeds of the same age. When dimensioning housing systems and equipment this has to be taken into consideration.

Recommendations

Table 10.4 indicates the recommended feeding and resting area dimensions for beef cattle.

Table 10.1. Birth weight, 200-day weight and 365-day weight for beef cattle breeds.

| Breed | Birth weight, kg | | 200-day weight, kg | | 365-day weight, kg | |
|---------------------------|------------------|---------|--------------------|---------|--------------------|---------|
| | Bulls | Heifers | Bulls | Heifers | Bulls | Heifers |
| Dexter | 21 | 20 | 155* | 134** | 265* | 224** |
| Highland Cattle | 30 | 28 | 192 | 176 | 285 | 248 |
| Piemontese | 46 | 41 | 248* | 254 | 428* | 368* |
| Belgian Blue White Cattle | 50 | 45 | 243* | 223* | 450** | 370* |
| Grauvieh | 41 | 38 | 331* | 242* | 464** | 423** |
| Hereford | 42 | 39 | 276 | 246 | 507 | 378 |
| Limousine | 41 | 39 | 291 | 254 | 515 | 392 |
| Aberdeen-Angus | 37 | 35 | 293 | 259 | 518 | 389 |
| Charolais | 49 | 46 | 310 | 280 | 559 | 444 |
| Simmental | 45 | 42 | 330 | 298 | 571 | 452 |
| Blonde d'Aquitaine | 49 | 45 | 331 | 300 | 580 | 442 |
| Danish Shorthorn | 36 | 35 | 296** | 234* | - | 349** |
| Salers | 40* | 36* | - | 256* | - | 352** |

200-day weight and 365-day weight have been corrected for date of weighing if the animal has been weighed at 200 +/- 60 days and 365 +/- 60 days. A 365-day weight has only been calculated if the animal already has a 200-day weight registered.

* = Less than 25 registered weighings.

** = 5 or less registered weighings.

Source: Kvægdatabasen, september 2000.

The indicated feeding area dimensions include dehorned and hornless animals. If horned animals are housed, it is necessary to increase the feeding area width and the resting area with up to 20% dependent on breed and the animals' temperament.

Calf sheds

In beef cattle herds cows often calve in the housing where calves and cows are housed together. The calf shed (See

figure 10.1) is recommended for two reasons:

- Calves can lie in shelter in between the suckling periods when the cows walk away to eat and drink.
- In the calf shed concentrate can be supplied for the calves to achieve a higher gain.

Autumn calving requires extra area in the deep litter. The extra space is e.g. to be used for the establishment of calf

Table 10.2. Weight and body dimensions among beef cattle breeds (individual test results for male animals 1999/2000).

| Breed | No of bulls | Weight, kg (392 days) | Height at withers, cm | Heart girth, cm | Thurl width, cm | Hip width, cm |
|---------------------------|-------------|-----------------------|-----------------------|-----------------|-----------------|---------------|
| Simmental | 39 | 669 | 130 | 198 | 52 | 48 |
| Highland Cattle | 7 | 363 | 108 | 165 | 40 | 40 |
| Danish Gelbvieh | 1 | 753 | 136 | 201 | 51 | 49 |
| Forest breed | 11 | 594 | 126 | 192 | 49 | 46 |
| Salers | 3 | 563 | 128 | 186 | 49 | 46 |
| Galloway | 1 | 495 | 108 | 183 | 43 | 44 |
| Aberdeen Angus | 12 | 606 | 126 | 196 | 50 | 49 |
| Limousine | 47 | 585 | 122 | 188 | 51 | 47 |
| Piemontese | 4 | 565 | 122 | 188 | 51 | 47 |
| Hereford | 18 | 584 | 126 | 191 | 50 | 48 |
| Blonde d'Aquitaine | 18 | 620 | 129 | 193 | 52 | 48 |
| Danish Shorthorn | 3 | 570 | 126 | 186 | 51 | 49 |
| Danish Charolais | 15 | 646 | 126 | 194 | 54 | 49 |
| Belgian Blue White Cattle | 4 | 550 | 126 | 191 | 51 | 45 |

Source: LK-meddelelse nr. 539. 4. september 2000. Landbrugets Rådgivningscenter, Landskontoret for Kvæg.

Table 10.3. Weight and body dimensions among beef cattle breeds (full-grown female animals).

| Breed | Weight, kg | Height at withers, m | Body length, m (shoulder/pin bone) | Hip width, m (thurl width) |
|-----------------|------------|----------------------|------------------------------------|----------------------------|
| Dexter | 325 | 1.00 | 1.30 | 0.40 |
| Highland Cattle | 550 | 1.18 | 1.45 | 0.48 |
| Galloway | 550 | 1.18 | 1.45 | 0.48 |
| Aberdeen Angus | 700 | 1.37 | 1.49 | 0.53 |
| Hereford | 750 | 1.35 | 1.40 | 0.52 |
| Limousine | 750 | 1.41 | 1.64 | 0.55 |
| Charolais | 800 | 1.39 | 1.57 | 0.54 |
| Simmental | 850 | 1.42 | 1.70 | 0.56 |

Chapter 10

sheds and calves must have the possibility of being supplied supplementary feed during the last months before weaning. Additionally the extra space is necessary as calves at weaning may weigh 250-300 kg weight and consequently start to require a larger area in the housing. The calf shed is dimensioned by 1.5 m² per calf.

At spring calving calf sheds are also established but this does not affect the cow resting area as the calves are only housed for one month on average.

Access to the calf shed must be designed in a way as to prevent cows from accessing the area. The calf shed opening must be 0.90 meter high and 0.4 meter wide and preferably with adjustable "rollers" in both door frames.

Calves of the smallest beef cattle breeds, e.g. Dexter, require smaller opening areas.

Feeding area

The choice is between a short or a long feeding area.

- The short feeding area is established with a slope towards the resting area and it should be no longer than the animals' body length. Access to

the feeding area in the entire pen width. The feeding area is self-cleaning. When animals go to and from it, manure is pulled down to the resting area where it is incorporated into the manure mat.

- The long feeding area is established with solid floor, which must be cleaned, or with slatted floor. The feeding area is to be wide enough for alongside traffic at the same time as animals are eating.
- If the pen is designed with deep litter at the entire area the feed trough height is to be adjusted to the height of the deep litter layer. This may require an adjustable feed trough.

Water

In general beef cattle need smaller amounts of water than dairy cattle. Recommendations for drinking water allocation, design and location of watering cups and water troughs can be seen in chapter 6, section 6.3.

Feeding rack

It is recommended to use self-locking feed barriers to be able to fix the animals. Recommended neck opening is at a minimum of 0.25 meters.

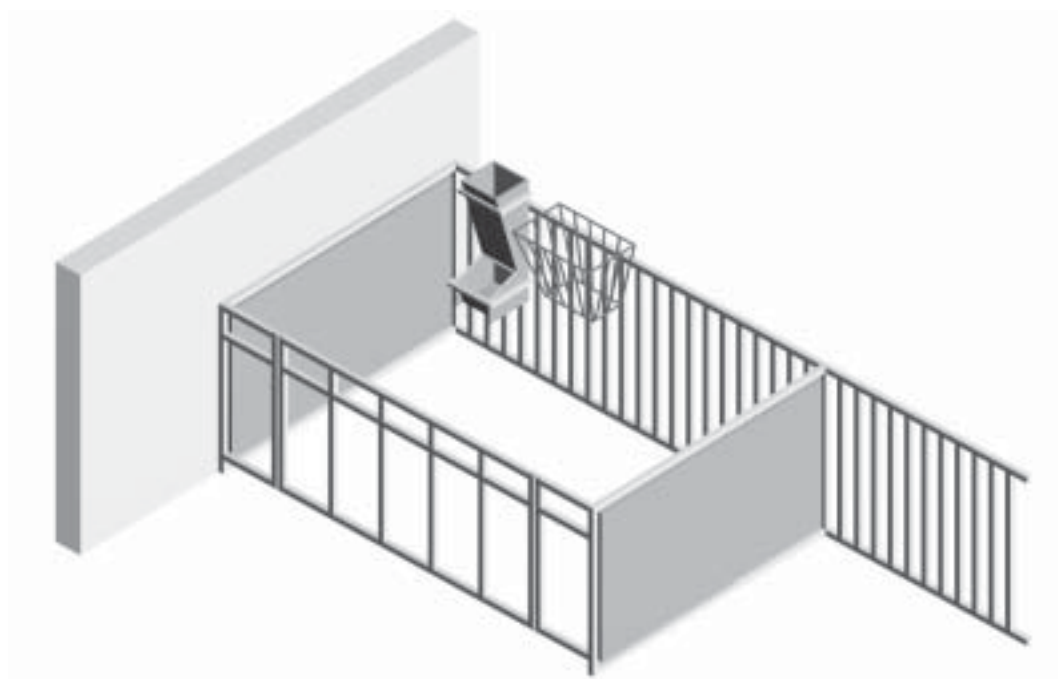

Figure 10.1.
A calf shed for sucklers in deep litter housing systems.

If self-locking feed barriers are not applied at the feeding rack, tethering and handling possibilities must be established somewhere else in the housing system, e.g. in the shape of a collecting fold with head gates.

It must be easy to free animals that fall while they are tethered by means of the self-locking feed barriers.

Manholes and gates

In loose housing systems an appropriate amount of manholes or smaller one-hand operated gates should be established. Manholes must ensure easy and untroubled access to the zones where animals are located in connection with supervision, treatments (e.g. insemination). Moreover, manholes must function as escape routes for the staff, if necessary. For information about design of manholes and gates, please see chapter 9. Dairy cows.

Background and motivation

Please see chapter 9. Dairy cows and chapter 8. Calves and young stock.

10.3 Literature

10.3.1 Sources

Kvægdatabasen, september 2000 (upubliceret data).

LK-meddelelse nr. 539. 4. september 2000. Landbrugets Rådgivningscenter, Landskontoret for Kvæg.

10.3.2 Supplementary literature

Foged, H. L., M.K. Schou, J.Y. Blom, 1995. Kød-kvæg-avl, fodring, pasning og økonomi. Jordbrugsforlaget.

Iowa State University, Arnes, Iowa, 1987. Beef Housing and Equipment handbook.

Anonym 2000. Fangefolde og indhegning til kvæg, 2. udg. Landbrugets Rådgivningscenter. Landskontoret for Kvæg. 26 pp.

Table 10.4. Recommended dimensions for beef cattle feeding and resting areas.

| | Feeding area, m | | | Resting area, m ² |
|---|----------------------------|-------------|-------------|---|
| | Width | Short | Long | |
| Sucklers, 600 - 800 kg | 0.75 - 0.90 Min. 0.25 * | 1.80 - 2.00 | 3.20 - 3.60 | 1 m ² /100 kg Live weight |
| Weaned first year calves, 200-499 kg | 0.50 - 0.60 | 1.40 - 1.65 | 2.40 - 2.80 | 2.5 - 3.5 |
| Second year calves, 300-699 kg | 0.55 - 0.70 | 1.55 - 1.80 | 2.60 - 3.20 | 3.0 - 4.5 |
| Young bulls, 200-599 kg | 0.50 - 0.65 | 1.40 - 1.75 | 2.40 - 3.00 | 2.5 - 4 |
| Breeding bulls | 0.75 - 0.90 Min. 0.25* | 1.80 - 2.00 | 3.20 - 3.60 | 1m ² /100 kg Live weight |

Bullocks are considered young stock in respect of area requirements. Please also see chapter 8.
* = Neck opening, preferably adjustable.

When using fully littered pens the deep litter area is to be at 20% larger because the animals stand on the mat when eating.
At autumn calving further 1.5 m² per cow are added to establish calf sheds.

Outdoor exercise folds

11.1 Outdoor exercise folds

Outdoor exercise folds are defined as consolidated areas placed in direct connection with the housing. Outdoor exercise folds give cattle the opportunity of outdoor exercise at all times of the year.

Recommendations

In order for the outdoor exercise fold to make out a comfortable place for cattle, it should be correctly located and preferably in shelter along the south and south-eastern sides of the buildings. Shelter can be established in the fold, e.g. by planting a windbreak belt or mounting wind-breaking nets along some of the exercise fold sides.

The recommended areas for the various weight groups are listed in table 11.1. The area is calculated from the number of animals, which has simultaneous access to the fold.

Dimensioning

The outdoor exercise fold is to be dimensioned from the maximum number of animals planned to have simultaneous access. This does not necessarily mean the entire herd at the same time. Division into groups makes it possible to let the individual groups have access to the outdoor fold in turn.

Construction of outdoor exercise fold

The outdoor exercise fold is to be demarcated in the sides with a berm and supplied with flooring, which cannot be penetrated by moist. The berm around the outdoor exercise fold must

prevent surface water from the surrounding areas from penetrating the outdoor exercise fold and at the same time ensure that manure and urine do not pollute the surrounding areas. The berm must be at a minimum of 20 centimetres above the outdoor exercise fold flooring.

The outdoor exercise fold flooring must slope 1.5 - 2% towards drain or drainage channel in order for urine and surface water to be channelled away. Surface water, manure and urine are channelled to a pre-storage tank or other storage. Amount of precipitation should be calculated the same way as when collecting rainwater at uncovered manure storage (0.7 m³/m²/year).

The outdoor exercise fold flooring must be slip resistant to improve the animal comfort (please see chapter 6, section 6.2 on floors).

To maintain good hygiene and good hoof health, outdoor exercise folds must be easy to clean. The cleaning of the fold will typically be carried out mechanically, e.g. with a tractor-mounted scraper. Cleaning of the fold must not cause wear and tear on the flooring, which will reduce the slip resistant safety of the flooring.

Access to the outdoor exercise fold can take place through gates and/or a cattle grid. A cattle grid can simultaneously function as a protected scraping down place for manure from the outdoor exercise fold. In connection with gates and cattle grids there should be a marginal zone with a solid flooring outside the outdoor exercise fold. Floorings in marginal zones are placed with slope towards drains and perhaps the cattle grid, if this functions as drain.

Fencing

The fencing around the outdoor exercise fold must be designed securely in order not to injure cattle at contact with the fencing or as a consequence of escapes from the fold.

Table 11.1. Recommended area in outdoor exercise folds, m²/animal.

| Animal weight, kg | Area, min m ² /animal |
|-------------------|----------------------------------|
| 100 | 1.5 |
| 200 | 2.0 |
| 300 | 2.5 |
| 400 | 3.0 |
| 500 | 3.5 |
| 600 | 4.0 |
| 700 | 5.0 |

A solid fencing may e.g. consist of:

- Cast in posts for each 2.5 meters of fencing. As a minimum the posts are to be in 0.75 m depth. Posts can e.g. be 75 millimetres steel tubes or 125 x 125 millimetres wooden poles.

Between the posts 4 horizontal rails or planks are placed 0.5 meters, 0.8 meters, 1.1 meters and 1.45 meters, respectively, above the ground. Examples of horizontal rails or planks may e.g. be:

- Steel tubes (5-centimetre diameter)
- Spring tightened steel wires (1-1.2 centimetres)
- Planed wooden planks (5 x 12.5 centimetres, on top 5 x 20 centimetres, however).

In outdoor exercise folds for calves and young stock it is possible to omit the upper horizontal rails or planks.

Background and motivation

- When grazing dairy cows walk 2-4 kilometres every day dependent on amount of grass and size of fold (Zeeb, 1983; Krohn et al., 1992)
- In loose housing systems with access to outdoor exercise folds the daily walking distance is approx. 1 kilometre (Zeeb 1983)
- It is considerably easier for exercising cows to get up and lie down than cows, which do not get any exercise (Gustafson et al., 1988; Krohn and Rasmussen, 1990)
- The reproduction conditions improve and the level of diseases decreases when cows in tied-up housing sys-

tems are offered regular exercise, e.g. summer grazing (Krohn, 1986).

11.2 Literature

11.2.1 Sources

Gustafson, G. M., M. Andersson & E. Lund. 1988. Getting up and lying down behaviour in tied and exercised dairy cows. SVE-summer meeting. Skara, Sverige.

Krohn, C. C. 1986. Motion til malkekøer i bindestalde. Ugeskrift for jordbrug, 46, 1364-1366.

Krohn, C. C. & M. D. Rasmussen. 1990. Motion til malkekøer. Medd. nr. 763 fra Statens Husdyrbrugsforsøg. 4 pp.

Krohn, C. C., L., Munksgaard & B. Jonasen. 1992. Behaviour of dairy cows kept in extensive (loose housing/pasture) or intensive (tie stall) environments. I. Experimental procedure, facilities, time budgets journal and seasonal konditions. Appl. Anim. Behav. Sci., 34: 37-47.

Zeeb, K. 1983. Locomotion and space structure in 6 cattle units. Farm Animal Housing and Welfare, Martinus Nijhoff Publishers for CEC.

11.2.2 Supplementary literature

Anonym, 1991. Færister til kvæg. Landbrugets Byggeblade grp. nr. 103.07-05. Landbrugets Rådgivningscenter. 2 pp.

Anonym. 1998. Handling the herd. Kondinin Group. 300 pp.

Anonym. 2000. Fangefolde og indhegning til kvæg. Landskontoret for Kvæg. Landbrugets Rådgivningscenter. 26 pp.

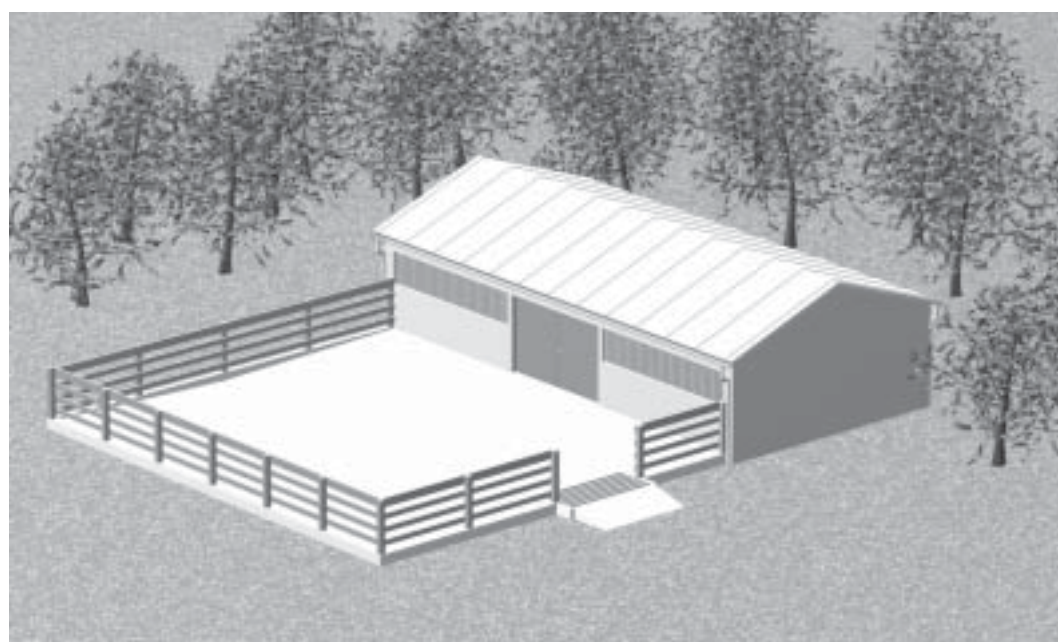

Figure 11.1.
Example of fencing
of an outdoor exercise
fold with cattle
grid.

Subject index

A

Abnormal behaviour 25
Ad-lib feeding 21, 95
Aggressive behaviour 15
Air humidity 47, 48
Air inlet 49
Air outlet 49
Alleys 77
Artificial teat 24, 79
Automatic feeder 78
Automatic feeding station 95, 96
Automatic milk feeder 79
Automatic milking system (AMS) 103

B

Back alleys 109
Bedding 18
Body dimensions 28
Brisket board 88, 91
Building insulation 48

C

Calf huts 69
Calf shed 64, 115
Calving 22
Calving pen 64
Catch-stall housing system 110
Cattle grid 118
Cattle senses 12
Circadian rhythm 16
Cleaning 36, 61
Cleaning-friendly floors 103
Climate 39
Climate tolerant 46
Climatic requirements 46
Coating 55, 59, 60
Collecting fold 117
Colostrum 24, 64
Comfort behaviour 19
Communication 13
Concentrate feeder 78
Concrete floors 54, 55
Condensed water 48
Cow alley 99
Cow trainer 109
Crossovers 99, 100, 109
Crowd gate 101
Cubicle 76, 86, 87, 99
Cubicle bedding 89
Cubicle partition 76, 87

D

Dairy cow 86
Deep litter 71, 86, 91
Direct exit 104
Disinfection 36
Draught 46, 47
Drift height 49
Drinking station 79
Drinking water 56
Drive alley 71
Dummy-teat 69
Dust 47

E

Entrance part 102
Entrance room 34
Equipment 54
Equipotential bonding 59
Exercise area 77, 99
Exercise fold 69
Exercise need 71
Exit part 104

F

Farm asphalt 59
Fast exit 104
Feed alley 109
Feed bowl 69
Feeder 103
Feeding area 77, 94, 99, 107, 116
Feeding cubicle 86
Feeding place 78, 94, 95
Feeding platform 96
Feeding rack 78, 95, 97, 116
Fencing 118
Flights 91
Flooring type 107
Floors 54
Front rails 87
Frost control 58

G

Galvanic corrosion 60, 61
Galvanisation 59
Gases 47
Grazing 20
Grooming 15, 19
Grounding connection 60
Guard rail 102

H

Handing over cattle 33
Hayrack 69
Heat production units 49
Herd handling 39
Herringbone parlour 103
High density of animals 13
Holding area 100
Hoof 54
Hoof bath 105
Hoof care 38
Hoof trimming 36, 100
Hoof wear 55
Hot rolled asphalt 54

I

Illumination 49
Immune response 24
Individual distance requirements 13
Infection protection 33, 35
Infectious disease 33, 35
Insulated building 48
Insulation 48

J

Joint pens 68
Jointly housed cattle 71

L

Landing 96
Light 47
Litter 76, 92
Loose housing 86
Lying down and getting up behaviour 16
Lying down time 90
Lying frequency 16
Lying place 18
Lying time 16

M

Manholes 95, 117
Materials 54, 59
Mats 89, 90
Mattresses 89, 90
Mechanical ventilation 46, 49
Medicine and chemical storage 36
Milk feeding 79
Milk storage room 55
Milking alley 55, 103
Milking area 100

Milking parlour 103
Milking stall 101, 103
Minimum ventilation 49
Mobile shelter 75

N

Natural ventilation 49
Neck rail 78
Neck rail tether 108
Night light 47
Nipple drinkers 69
Nursing cow system 25

O

One-way gate 105
Operator pit 55
Optimal group size 14
Orientation light 47

P

Painting 59
Parallel parlour 103
Partition 87, 90, 91, 92, 96, 107
Pen area 71
Precipitation 47
Profiled surface 54
Purchase of cattle 33

R

Raised feeding platform 97
Ramps 91
Ranking 14
Rear kerb 76, 88
Reconstruction programme 35
Relative air humidity 47
Reproduction 22
Resting area 71, 87
Restrictive feeding 21
Return alley 104
Roof ridge 51
Rotary milking parlour 103
Rumination 21

S

Sand 89
Sand bedding 76
Sawdust 66, 76, 89
Scrapers 96
Self-cleaning sloping pen 87
Self-locking feed barrier 78, 94, 95, 97, 106, 117

Separation 31, 35
Separation area 104, 106
Separation gate 106
Separation section 35
Shavings 66
Shelter 75
Sidewalls 51
Single pen 68
Slatted floor 56, 77
Sliding chain collar tying 71, 108
Slip resistant
 54, 55, 56, 78, 89, 91, 99, 100, 103
Slip resistant coefficient 90, 91
Slope 77, 86, 89, 90, 91, 96
Social behaviour 13
Solid floor 54, 96
Sound 48
Stall 70, 106
Stereotypies 25
Sticking effect 50, 51
Straw 76
Straw mats 89
Straw mattresses 76
Supervision 38, 39, 117
Surface temperature 47
Surface treatment 59

T

Tandem parlour 103
Teat bucket 68, 69, 79
Teat-dummies 79

Temperature 46
Tethers 108
Thermoregulation 46
Tied-up housing system 106
Treatment section 35
Trough 78, 97
Trough design 94, 107

U

Uninsulated building 48

V

Ventilation 48, 49, 51
Ventilation area 49, 51

W

Walking alley 99, 109
Waste handling 36
Water intake 21
Water supply 58
Water trough 57, 95
Watering cup 57
Weaning 25
Wind speed 46, 47
Wind-breaking covering 51
Winter climate 46
Wood shavings 76, 89
Work routines 38
Working light 47

